

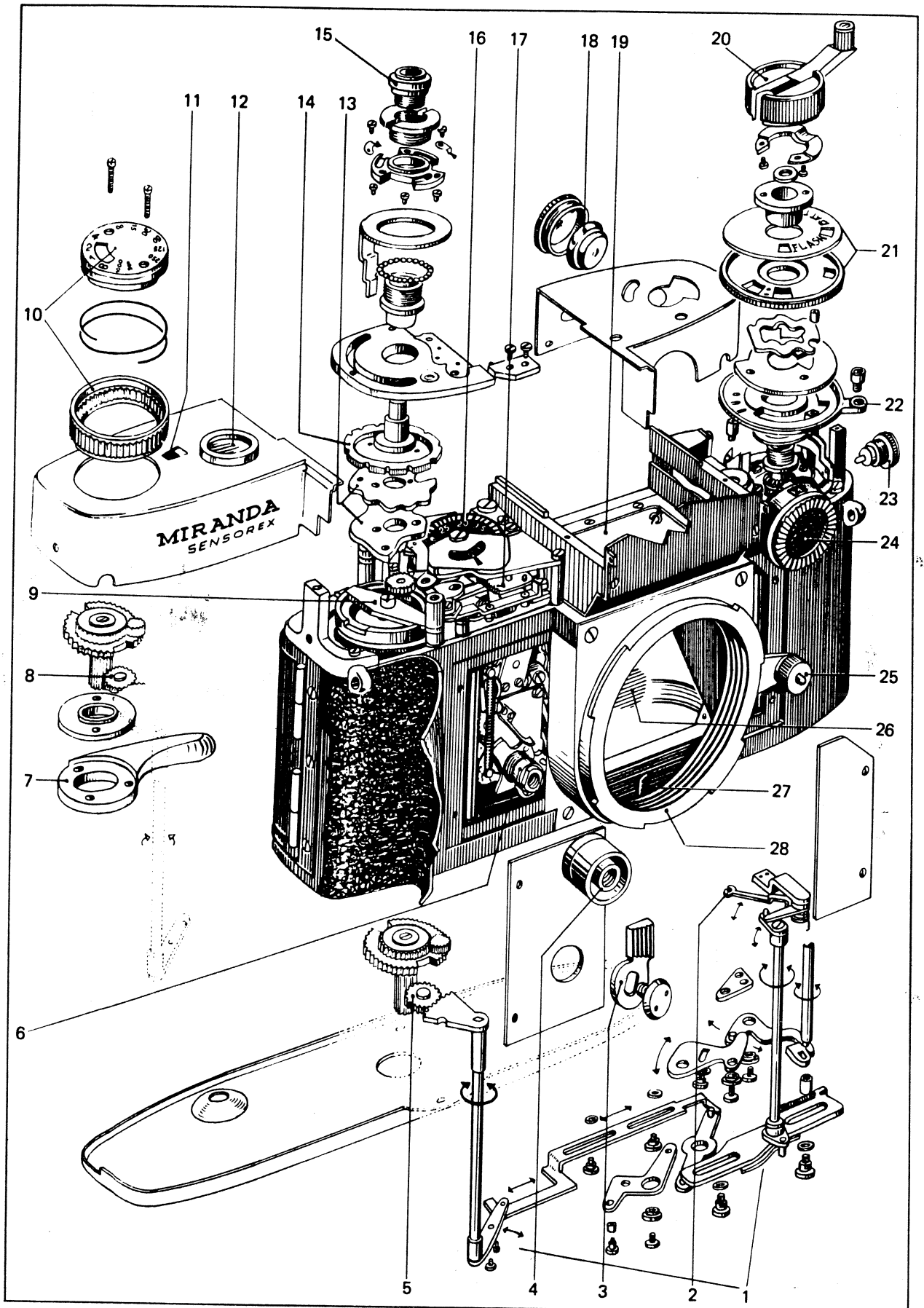
# MIRANDA

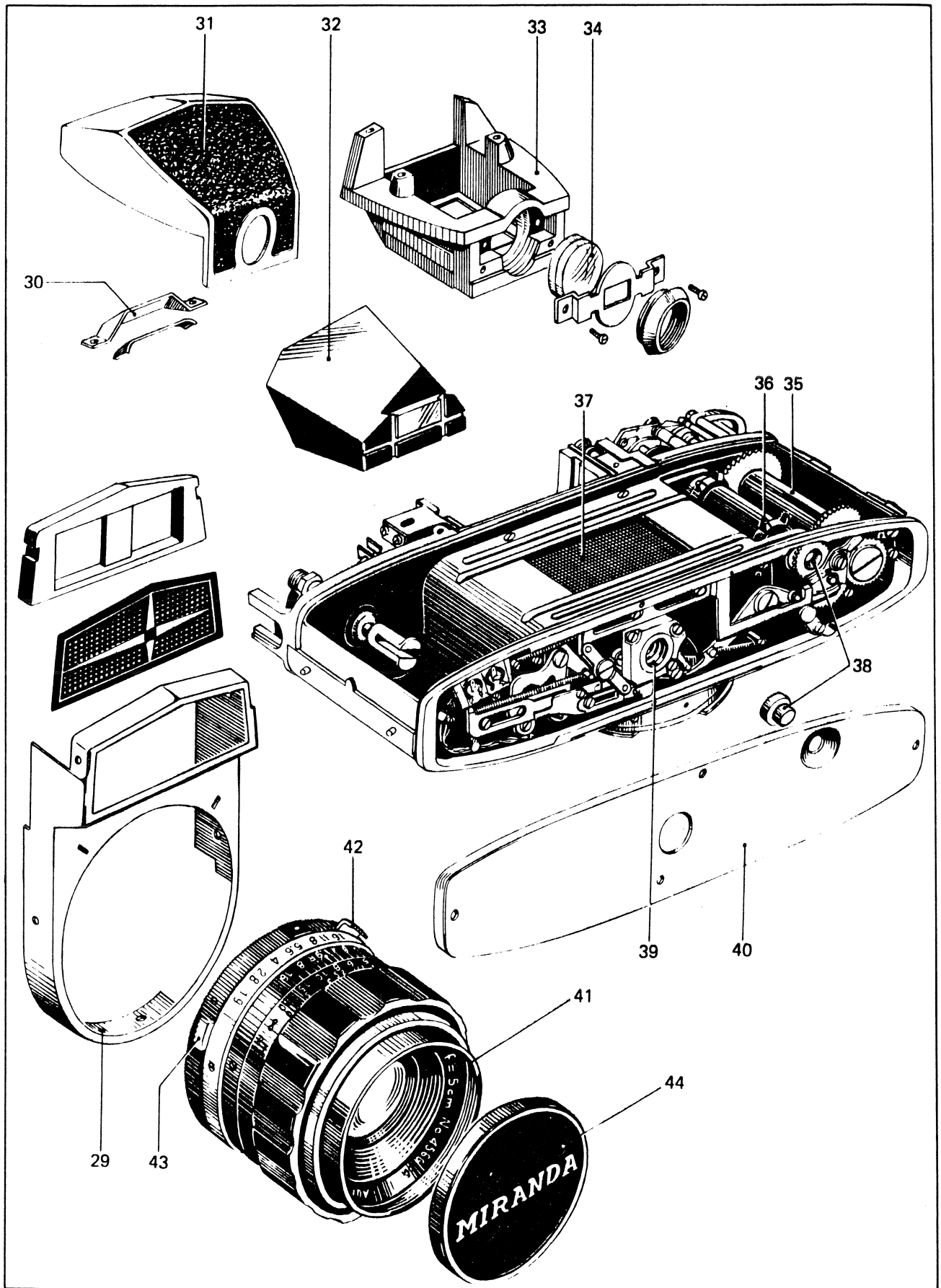
# *SENSOREX*

SERVICE MANUAL











## Index Table for Exploded Diagram

Index No.	Name of Parts	Parts No.
1	<i>bottom mechanisms, including</i>	
	<i>base plate assembly for diaphragm cam</i> .....	SK - 50
	<i>diaphragm connecting lever assembly</i> .....	SK - 22
	<i>LS (lens selector) lever assembly</i> .....	SK - 54
	<i>shutter connecting lever</i> .....	ML - 10
	<i>lower link assembly</i> .....	AK - 18 and AK - 37
	<i>ASA gear assembly</i> .....	AK - 14 - 1
	<i>link cam assembly for follow needle</i> .....	AK - 33
	<i>bearing for follow needle</i> .....	ML - 45
	<i>spring for follow needle</i> .....	ML - 34
	<i>lead lever assembly</i> .....	SK - 44
2	<i>follow needle</i> .....	AK - 36
3	<i>self-timer starting lever</i> .....	MT - 17
4	<i>shutter release button</i> .....	MS - 63
5	<i>intermediate gear for ASA gear</i> .....	ML - 5
6	<i>rotating cam for self-timer</i> .....	MT - 13
7	<i>film winding lever</i> .....	MW - 40
8	<i>--- same as #5 in the above ---</i> .....	ML - 5
9	<i>spring case holder assembly</i> .....	AK - 17
10	<i>shutter speed dial</i> .....	MS - 68 or MS - 69
	<i>and ASA speed adjusting ring</i> .....	MS - 67
11	<i>shutter speed index with film wind indicator</i> .....	MC - 45
12	<i>exposure counter</i> .....	MC - 43 and FC - 31
13	<i>shutter speed cams</i> .....	MS - 37 and MS - 38
14	<i>shutter speed dial click disc</i> .....	MS - 40
15	<i>shutter speed dial base</i> .....	MS - 42
16	<i>counter scale dial</i> .....	MC - 33
17	<i>segment gear in shutter governor assembly</i> .....	MS - 51
18	<i>mercury battery</i> .....	ML - 51

19	focusing screen assembly, consisting of ,	
	focusing screen holder .....	MI -- 28
	condenser lens .....	MI -- 32
	spring for condenser lens .....	MI -- 30
	washer with "O" position mark .....	MI -- 30A
	focusing screen .....	PI -- 508A
20	rewind crank assembly .....	AK -- 42
21	synch. contact selector assembly .....	AK -- 41 - 1
22	Cds meter switch lever assembly .....	AK -- 41 - 3
23	synch. terminal .....	MF -- 25
24	lens selector dial, consisting of .....	ML -- 98, ML -- 99, SK -- 47, ML -- 95, ML -- 94, SK -- 45, ML -- 103C, MI -- 50, ML -- 93, ML -- 92, etc.
25	diaphragm setting lever, consisting of .....	MB -- 9, MB -- 10 and MB -- 10A
26	Cds cell, behind reflector mirror .....	MK -- 22 - 7
27	diaphragm actuator lever .....	MI -- 6
28	bayonet mount of lens mount assembly .....	AK -- 26
29	front cover .....	MB -- 11 - 4
30	prism supporter .....	MP -- 2
31	prism cover .....	MP -- 4 - 1
32	pentaprism .....	PP -- 8
33	prism case .....	MP -- 1
34	eyepiece lens .....	PP -- 805
35	film spool assembly .....	AK -- 5
36	sprocket .....	MW -- 37
37	shutter curtain .....	AK -- 9, and AK - 10
38	film rewind release button .....	MW -- 38
39	tripod adapter .....	MB -- 4
40	bottom cover .....	MB -- 13 - 4
41	standard lens .....	--- N/C ---
42	preview lever; for f/1.4 50mm lens .....	ZB 137 - 24
	for f/1.8 50mm lens .....	Y 46 - 110
43	lens locking lever; for f/1.4 50mm lens .....	ZB 137 - 25
	for f/1.8 50mm lens .....	Y 45 - 35
44	lens cap; for f/1.4 50mm lens .....	ZB 65 - 19
	for f/1.8 50mm lens .....	Y 45 - 10

**Section 1 Disassembly****CONTENTS**

Item No.	Name of Parts	Part No.	Page
1	<i>Front Cover</i>	<i>MB-11-4</i>	1
2	<i>Right Cover</i>	<i>SK32</i>	2
3	<i>Left Cover</i>	<i>SK40</i>	3
4	<i>Bottom Cover</i>	<i>MB13-4</i>	4
5	<i>Right Front Cover</i>	<i>AK27</i>	5
6	<i>Left Front Cover</i>	<i>MB23-1</i>	6
7	<i>Lens Mount Assembly</i>	<i>AK26</i>	7
8	<i>Mirror Housing Light Baffle</i>	<i>MI38</i>	8
9	<i>Mirror Housing Assembly</i>	<i>SK21</i>	9 & 10 & 11

## Section 2 Assembly and Adjustment

## TABLE OF CONTENTS

---

	Page
<i>Item 1 Shutter</i>	
1. <i>Shutter curtain</i>	
a.) <i>Adjusting Gap between the curtains</i>	12
b.) <i>Starting position of 1st curtain</i>	12/13
c.) <i>Tension strength of 2nd curtain spring</i>	13
d.) <i>Tension strength of 1st curtain spring</i>	14
e.) <i>Curtain travel speed</i>	14
2. <i>Shutter exposure speed</i>	
a.) <i>Caution</i>	14
b.) <i>Adjustment</i>	15
(1) <i>1/1000 sec. high speed</i>	
(2) <i>1/15 sec. low speed</i>	
(3) <i>Adjustment of speed cams (MS-37, MS-38)</i>	
3. <i>Shutter button</i>	16
a.) <i>Stroke</i>	
b.) <i>Timing</i>	
c.) <i>Pressure of shutter button</i>	
 <i>Item 2 Film Winding</i>	
1. <i>Position of stopper when fully wound</i>	17
2. <i>Position of winding ratchet when fully wound (AK-14)</i>	17
3. <i>Position of lever return spring</i>	17
4. <i>Mirror setting lever gear position (AK-24)</i>	18
5. <i>Anti-reverse claw</i>	18
6. <i>Position of diaphragm lever</i>	19
7. <i>Spring tension of diaphragm lever</i>	19

## TABLE OF CONTENTS (continued)

---

	Page
<i>Item 3 Exposure Meter</i>	
1. <i>Adjustment of meter</i>	
a.) <i>Zero position</i>	20
b.) <i>Distance between meter needle and follow needle</i>	20
c.) <i>Deflection angle of meter needle</i>	20
c-1.) <i>Low intensity</i>	21
c-2.) <i>Medium intensity</i>	21/22
c-3.) <i>High intensity</i>	22
2. <i>Follow needle adjustment</i>	23
3. <i>ASA Dial adjustment</i>	23
4. <i>Lens aperture dial</i>	24
 <i>Item 4 Mirror</i>	
1. <i>Fitting position</i>	25

## Section 3 Malfunction Symptoms and Repair Guide

## TABLE OF CONTENTS

---

	Page
Item 1 Shutter	
1. Curtain	
a.) Dust or metal chips between gears	26
b.) Loose or incorrect positioning of release gear	26
c.) Insufficient pressure of shutter button	26
d.) Insufficient turning of film winding lever	
(1) Bent intermediate lever	26
(2) Release lever failure	27
(3) Jamming of shutter release gear	27
(4) Dust or metal chips between gears	27
2. Mirror Housing	
a.) Incomplete stroke of mirror setting lever	27
b.) Weakening of springs	27
c.) Loose release lever	28
d.) Loose mirror actuator lever	28
e.) Mirror frame jammed	28
3. Self-timer	
1. Self-timer does not operate	
a.) Failure of control lever	29
b.) Defect in self-timer	29
2. Self-timer operates incorrectly	
a.) Starting lever operates incorrectly	29
b.) Click spring not operating	29
4. Exposure Speed	
1. Too slow at high shutter speeds	
a.) 1st curtain too fast	30
b.) 2nd curtain too slow	30
c.) Governor does not operate properly (too sluggish)	30
d.) Defect in speed cams	30
e.) Governor lever does not operate properly	30

## TABLE OF CONTENTS for Section 3 (continued)

	Page
2. Too fast at high shutter speeds	
a.) 1st curtain too slow	31
b.) 2nd curtain too fast	31
c.) Governor does not operate properly	31
d.) Defect in speed cams	31
3. Too slow at low shutter speeds	
a.) Governor does not operate properly (too heavy)	31
b.) Governor lever jammed	32
4. Too fast at low shutter speeds	
a.) Governor does not operate properly	32
b.) Governor lever defaced and operates too loosely	32
5. Shutter curtain travels without completing a slit	
a.) Winding lever does not operate completely	33
b.) Governor lever does not operate sufficiently	33
c.) Governor does not operate properly	33
d.) Incomplete operation of release lever	34
6. 2nd curtain does not close	
a.) Dust or metal chips between gears	34/35
b.) Defect in governor	35
c.) Insufficient operation of governor lever	35
d.) Loose or incorrect positioning of release gear	35
 Item 2 Winding	
1. Winding lever fails to turn, but shutter operates	
a.) Dust or metal chips between gears	36
b.) Intermediate lever bent	36
c.) Ratchet wheel broken	36
d.) Winding claw broken or operates improperly	37
e.) Improper gearing of winding ratchet gear	37
f.) Clutch sticks	37
2. Winding lever fails to turn and shutter also does not operate	
a.) Incorrect positioning of diaphragm lever and its related mechanism	38
b.) 2nd curtain pinion loose	38/39
c.) Curtain release lever and mirror release lever jammed	39
d.) Mirror actuator lever and pin jammed	40

## TABLE OF CONTENTS for Section 3 (continued)

	Page
<i>Item 3 Film Counter</i>	
1. <i>Film counter does not turn forward</i>	
a.) <i>Incorrect positioning of stopper claw</i>	41
b.) <i>Release lever operation insufficient</i>	42
c.) <i>Wrongly connected springs</i>	42
d.) <i>Ratchet out of order, gear broken</i>	43
2. <i>Film counter does not return to the "START" position</i>	
a.) <i>Broken or disconnected return spring</i>	43
b.) <i>Malfunction of release lever</i>	43/44
c.) <i>Incorrectly connected springs</i>	44
d.) <i>Inaccurate reading caused by discrepancy between dial scale and red-mark indicator</i>	44/45
<i>Item 4 Synchronization</i>	
1. <i>Defective circuit</i>	
a.) <i>Wires disconnected</i>	46
b.) <i>Incorrect or high resistance contact due to deteriorated or rusty contacts</i>	46
2. <i>No contact</i>	
a.) <i>Dust or metal chips between contacts</i>	46
b.) <i>Contact malfunction due to</i>	
(1) <i>Fastened too tightly</i>	
(2) <i>Affected by moisture</i>	
(3) <i>Became covered with oil</i>	
(4) <i>Metal chips attached</i>	46
3. <i>Incorrect time-lag in X-contact</i>	
a.) <i>Too fast - 1st curtain remains in picture format</i>	47
b.) <i>Too slow - 2nd curtain remains in picture format</i>	47
4. <i>Incorrect time-lag in FP-contact</i>	
a.) <i>Too short - contact is made too early</i>	47
b.) <i>Too long - contact is made too late</i>	47
<i>Item 5 Focus</i>	
1. <i>Viewfinder</i>	
a.) <i>Mirror incorrectly positioned at 45° angle</i>	48
b.) <i>Inaccuracy in focusing screen</i>	48
2. <i>Film plane</i>	
a.) <i>Improper mounting of lens</i>	49
b.) <i>Pressure plate bent</i>	49
<i>Adjustment of distance between lens mount and film guide rails</i>	50



## TABLE OF CONTENTS for Section 3 (continued)

---

	Page
Item 6 Exposure Meter	
1. Follow needle failure	
a.) Caught in wiring	51
b.) Insufficient coupling of levers in bottom mechanism	51
c.) Cam roller disconnected from diaphragm cam	52
d.) Disconnected springs in bottom mechanism and on the follow needle	52
e.) Axis of follow needle out of alignment	52
f.) Follow needle catching or sticking	53
2. Meter needle failure	
a.) Disconnected wires	54
b.) Short circuit in wiring	54
c.) Dust or metal chips in meter movement	54
d.) Defect in meter needle buffer	55
e.) Meter needle bent	55
f.) Incorrect fitting position of meter movement	55
3. Incorrect reading of light value (LV)	
a.) At low intensity (LV-5 and 7)	55
b.) At medium and high intensity (LV-11 and 15, LV-17)	55
4. Incorrect LENS SELECTOR (LS dial) operation	
a.) Follow needle sluggish when the lens speed dialed from 1.4 to 1.8 (or 1.9)	55
b.) Indefinite click stops	56
c.) Loose fitting of lens speed selector ring	57
d.) Friction between leading screw and the stud	57
e.) Incorrect setting of rivet in lens speed selector ring cover	57
f.) Incorrect fitting position of coupling levers in bottom mechanism	57

## Section 4 Special Test Equipment

## TABLE OF CONTENTS

	(Use)	(Equipment)	Page
Item 1	Shutter	1. Shutter Tester. Model PA-23D	58/61
Item 2	Shutter Curtain and Auto- diaphragm Mechanism	1. Tension Gauge (dial), 0g – 300g 2. Tension Gauge, 0g – 300g	62 62
Item 3	Meter Needle	Scale Adjusting Plate. Model T-86	63/64
Item 4	Reflecting Mirror:	45° Mirror Angle Measuring Equipment, Model T-85	65

★ ★ ★ ★ ★ ★ ★ ★ ★ ★ ★ ★ ★ ★ ★

Note: Other instruments which are available but not listed here are:

Light Value Meter. Model T-121.

Insulation Resistance Meter. Model T-122.

Auto Collimator. Model T-130.

**Section 5 Special Repair Tools**

**TABLE OF CONTENTS**

---

	Page
<i>One Complete Set of Special Sensorex Tools</i>	66

★ ★ ★ ★ ★ ★ ★ ★ ★ ★

**Section 6 Parts List**

---

	Page
<i>Complete Sensorex Parts List</i>	67/78

★ ★ ★ ★ ★ ★ ★ ★ ★ ★



**SECTION 1  
DISASSEMBLY**



Section 1 Disassembly

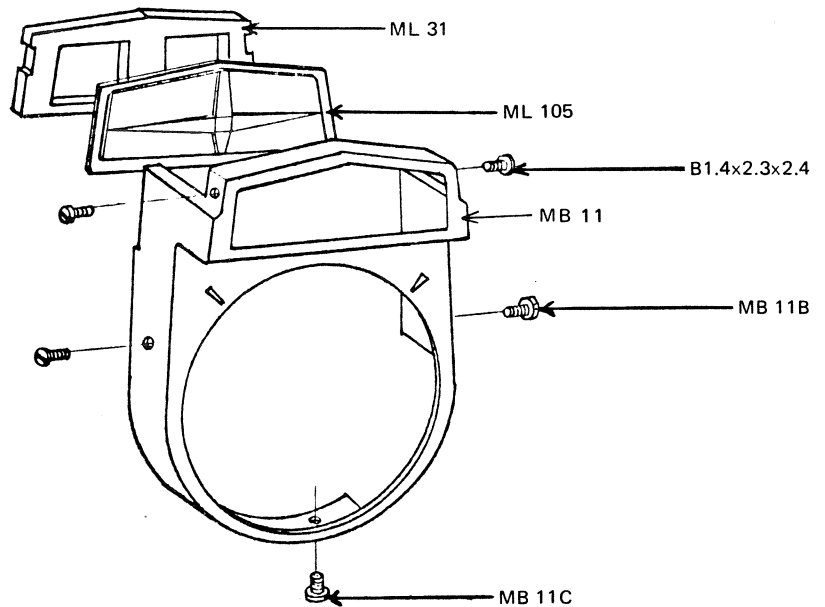
Item 1 Front Cover – Part No. MB 11-4

Step No.	Procedure	Illustration
----------	-----------	--------------

- a.) Camera must be removed from case.
  - b.) Lens and pentaprism must be removed from camera body.
- 1.2 Lift front cover away from body.
- 1.3 Remove decorative plate, ML105, supporting plate ML31B and grid plate ML31-3.

Note: In the latest model Sensorex cameras, supporting plate ML31B, and grid plate ML31-3 have been replaced by a spacer plate, ML-31.

Fig. 1.1



## Section 1 Disassembly

## Item 2 Right Cover – Part No. SK-32

Step No.	Procedure	Illustration
----------	-----------	--------------

- a.) Camera must be removed from case.
- b.) Lens and pentaprism must be removed from camera body.
- 2.1 Remove 2 screws, S 1.4 x 5.2 x 2 x 0.8, holding shutter speed dial, MS68-6, (later type, MS68-69).
- 2.2 Lift off shutter speed dial, MS68-6 or MS68-69.
- Caution: Before removing the following spring, be sure to note the starting position of the needle and the position of the ASA dial at the fully open lens aperture. It is important for reassembly.
- 2.3 Remove spring MS-67A, from under dial.
- 2.4 While holding ASA dial down with finger lift and remove knurled ring, MS67A-1.
- 2.5 ASA speed dial assembly, AK35, may be removed.
- 2.6 Lift off geared ring assembly MS66-B.
- 2.7 Retaining plate, AK52, should have a score mark for replacement, if missing, mark same before removing the retaining plate.
- 2.8 Remove 3 screws, MS65A-1, from edge of retaining plate, AK-52.
- 2.9 Lift off AK52 plate.
- 2.10 Remove 3 screws, S 1.7 x 2.5 x 2.5 x 1 from winding lever MW-40.
- 2.11 Lift off MW-40 lever.
- 2.12 Remove 3 screws, B 1.4 x 2 x 2.4 x 0.2 as per figure 2.12 from cover SK-32.
- 2.13 Lift off right cover, SK-32.

Fig. 2.1

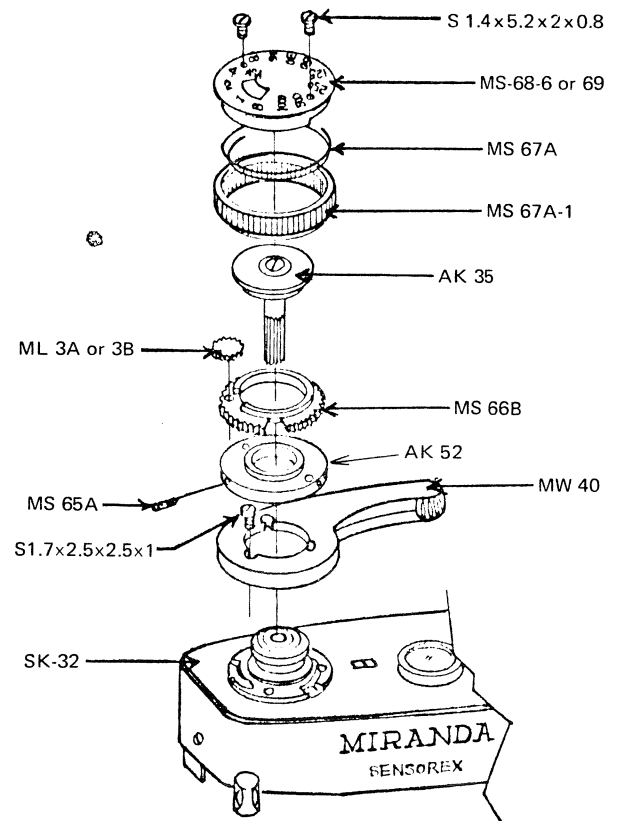
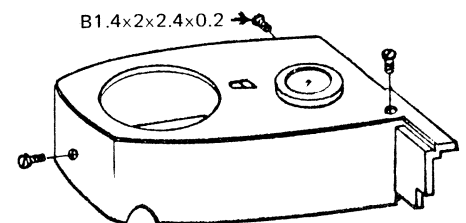


Fig. 2.12





## Section 1 Disassembly

## Item 3 Left Cover – Part No. SK-40

Step No.	Procedure	Illustration
----------	-----------	--------------

3.1 Remove front cover, Part No. MB11-4 as described in Item 1.

3.2 Remove back cover as described in camera instruction book.

Note: Later models did not have removable backs.

3.3 Unscrew film rewind crank assembly, AK42, by turning the film rewind crank counter clockwise while holding the film rewind stud, MW50-6, with a screwdriver placed through the slot in the film rewind stud.

3.4 Remove washer, MW-55, from shaft, (washer is sometimes left out if it is not needed). (Later model cameras may have no washer.)

3.5 Unscrew ring, MW-54, with spanner wrench.

3.6 Lift off the following;

- a.) top plate, AK41-1
- b.) spring washer, MF24G
- c.) printed plate, (with ball bearings) AK41-2
- d.) switch plate, AK41-3
- e.) washer, MF-24F

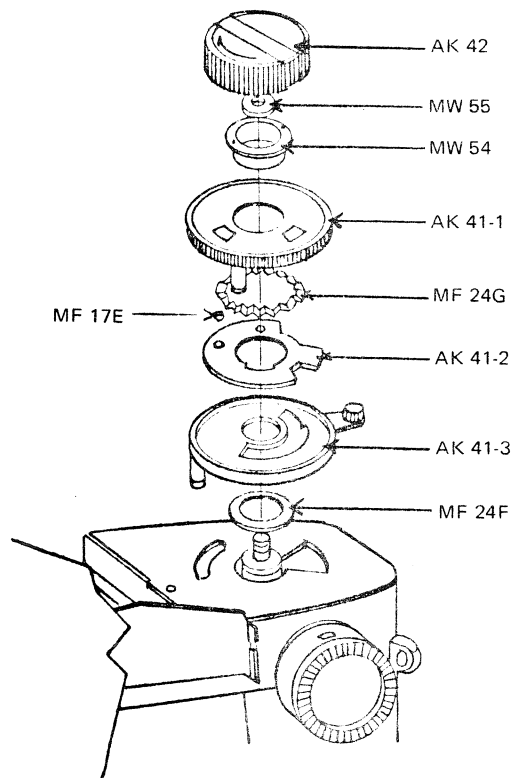
3.7 Unscrew prism lock button, MI-36, (Longer lock button is part No. MI-36A). Take out spring, MI-34, locking pin, MI-35, in prism mounting channel. A small washer under MI-36 may be present, be sure to look for it.

3.8 Unscrew 3 screws from the cover, Part No. B1.7 x 2 x 2.4 x 0.2, on the end of the cover - B1.4 x 2 x 2.4 x 0.2 from back of cover - B1.4 x 2.3 x 2.4 from top of cover.

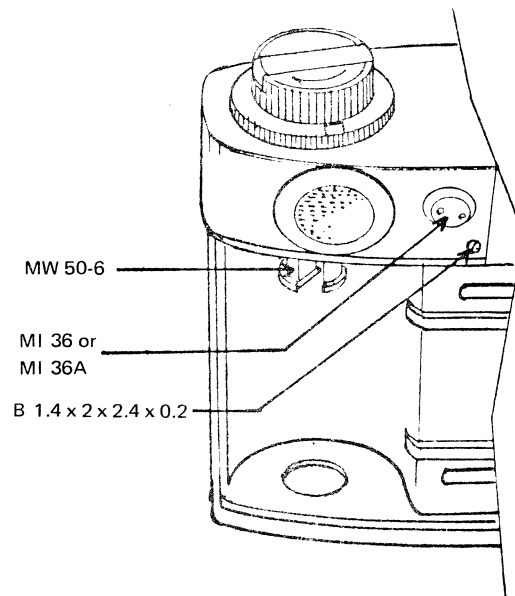
3.9 Lift off cover.

**Fig. 3.3**

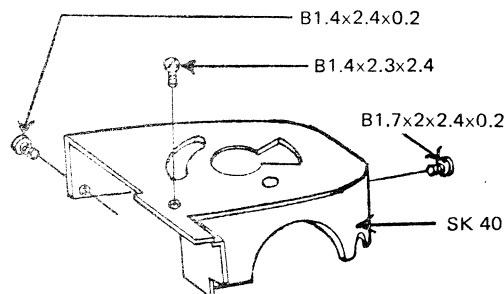
**Fig. 3.6**



**Fig. 3.7**



**Fig. 3.8**



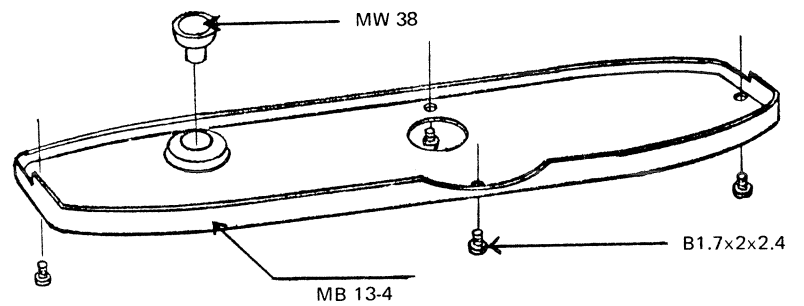
## Section 1 Disassembly

## Item 4 Bottom Cover – Part No. MB13-4

Step No.	Procedure	Illustration
----------	-----------	--------------

- a.) *Camera must be removed from case.*
- 4.1 *Unscrew 4 base plate screws, Part No. B 1.7 x 2 x 2.4.*
- 4.2 *Lift off bottom cover, watching for rewind release button, MW38, which is completely free and should be removed from the base of the camera once the bottom cover has been removed.*

Fig. 4.1



## Section 1 Disassembly

### Item 5 Right Front Cover – Part No. AK27

Step No.	Procedure	Illustration
----------	-----------	--------------

- 5.1 Remove front cover, MB11-4, as described in Item No. 1.
- 5.2 Remove self-timer lever by unscrewing retaining screw, MT16, with spanner wrench or needle-nosed pliers. Lever MT17 now lifts off.
- 5.3 Loosen shutter release button collar, MS64; removal of the shutter release button collar is not necessary.
- 5.4 Lift off leather covering, MB24-1 (MB24-4 in later model), with skinning tool, (wide flat bladed screwdriver may be used if a skinning tool is not available). A few drops of alcohol may be used to loosen the glue under the leather covering, if necessary.
- 5.5 Remove 2 screws, B 1.4 x 2 x 1.9.
- 5.6 Lift off cover, AK27.

*Note: remove old glue from back of leather and camera body before re-assembling.*

Fig. 5.2

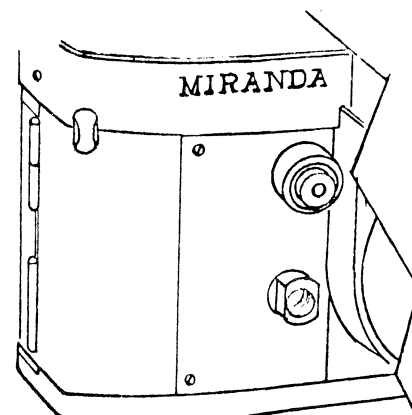


Fig. 5.3

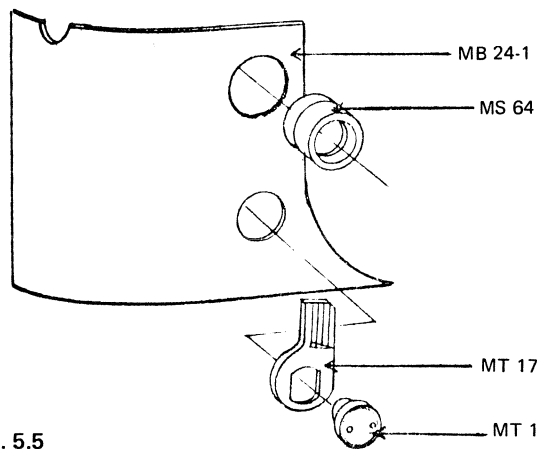
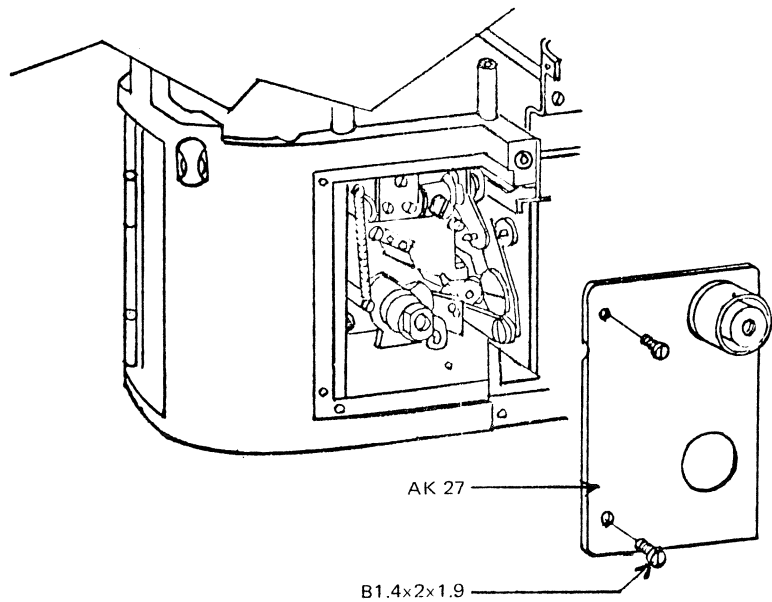


Fig. 5.5



## Section 1 Disassembly

## Item 6 Left Front Cover – Part No. MB23-1

Step No.	Procedure	Illustration
6.1	Remove front cover, MB11-4, as described in Item 1.	
6.2	Lift off leather covering, MB 25-2 (MB25-4 in later model), with skinning tool, (a wide flat bladed screwdriver may be used if a skinning tool is not available). A few drops of alcohol may be used to loosen the glue under the leather covering, if required.	
6.3	Remove 2 screws, B 1.4 x 2 x 1.9.	
6.4	Lift off cover, MB23-1.	

Note: remove old glue from back of leather and camera body before re-assembling.

Fig. 6.2

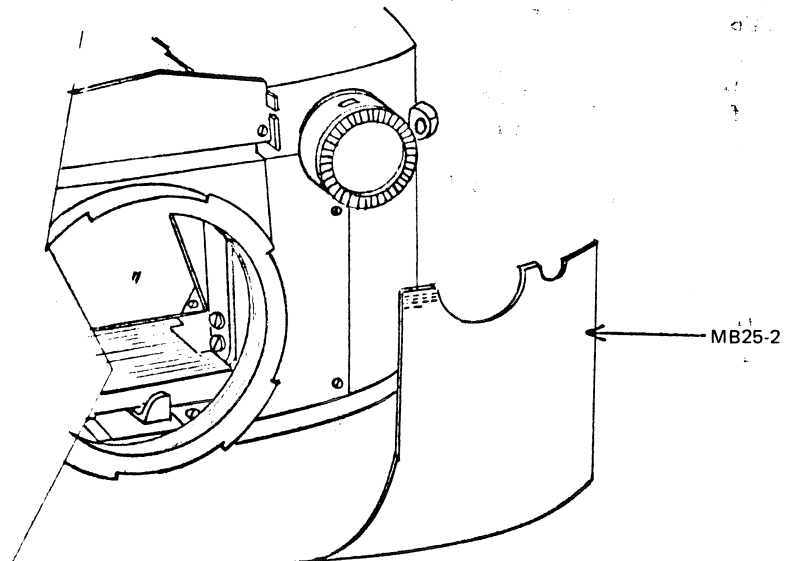
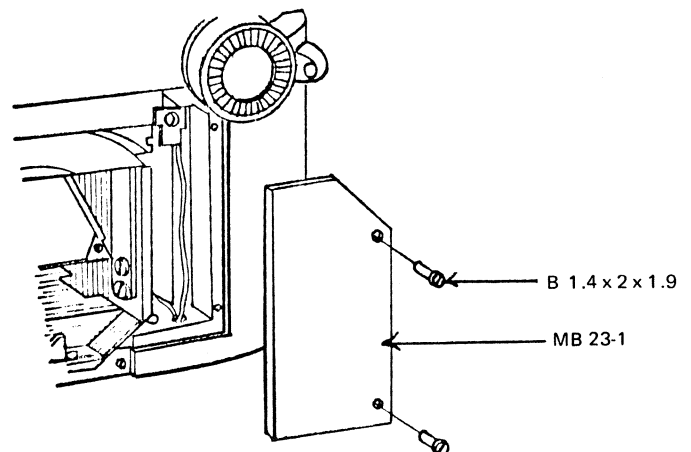
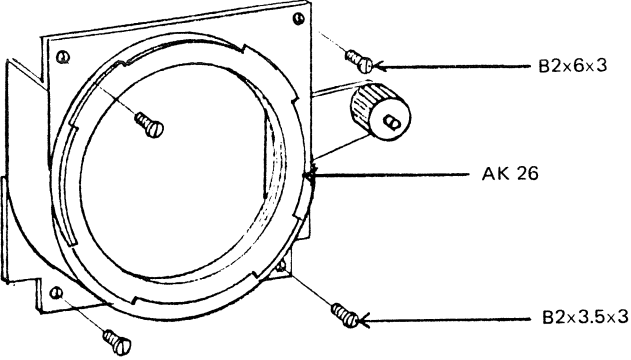


Fig. 6.3



## Section 1 Disassembly

## Item 7 Lens Mount Assembly – Part No. AK-26

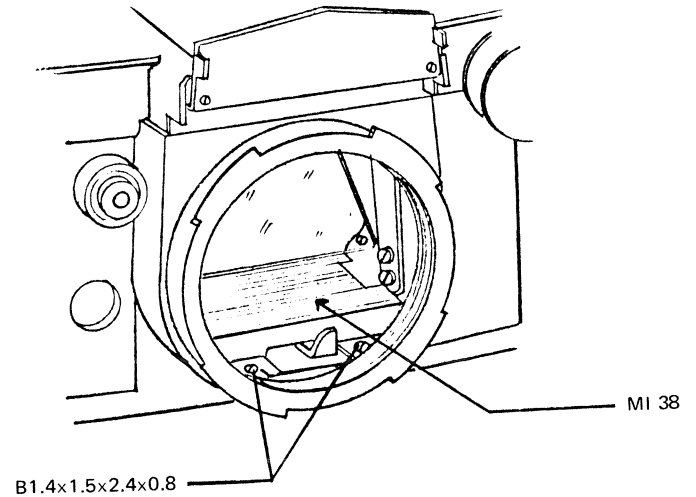
Step No.	Procedure	Illustration
7.1	Remove front cover, MB11-4, as described in Item 1 and Baseplate MB13-4 as described in Item 4.	
7.2	Remove 2 screws, B 2 x 6 x 3 (+2 x 3.5 x 3 x 0.8 in later model cameras), from top left and top right of lens mount assembly, AK26.	Fig. 7.2
7.3	Lift leather covering at base of lens mount assembly, with skinning tool, (a wide flat bladed screwdriver may be used if a skinning tool is not available), until the 2 screws at the bottom left and bottom right are visible. Remove the 2 screws, B 2 x 3.5 x 3 (+2 x 3.5 x 3 x 0.8 in later model cameras).	
7.4	Place camera flat on its back. Lift off AK26. Watch for small adjustment washers of different thicknesses which are used to adjust the lens mount depth, be sure to keep the washers separate from one another and in such a manner as to be able to replace the same washers under the same screw point from where it was removed.	
	<i>Note: Philips cross headed screws are used in the latest cameras at the points mentioned in steps 7.2 and 7.3.</i>	

## Section 1 Disassembly

## Item 8 Mirror Housing Light Baffle – Part No. MI38

Step No.	Procedure	Illustration
8.1	<i>Remove lens.</i>	
8.2	<i>Remove 2 screws, B 1.4 x 1.5 x 2.4 x 0.8 at front of baffle.</i>	
8.3	<i>Lift mirror out of the way by holding it at the top of the mirror housing with a finger.</i>	
8.4	<i>While holding mirror out of the way lift baffle up and outward. A small holding lip is on the underside of the rear of the baffle so that the baffle must be lifted upward first and then outward in order to free it.</i>	

Fig. 8.2



## Section 1 Disassembly

## Item 9 Mirror Housing Assembly – Part No. SK21

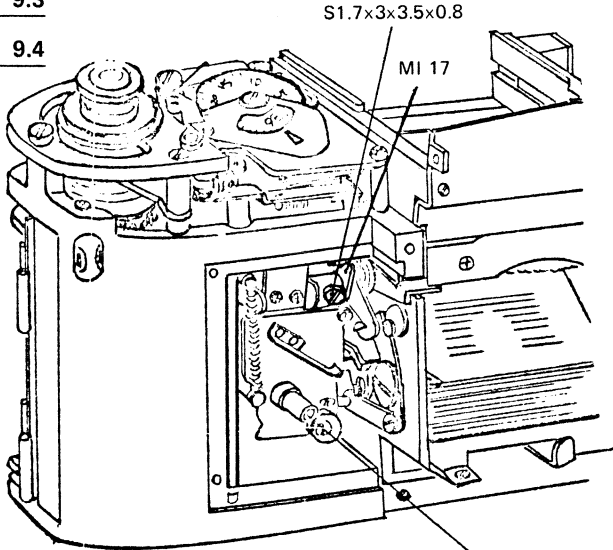
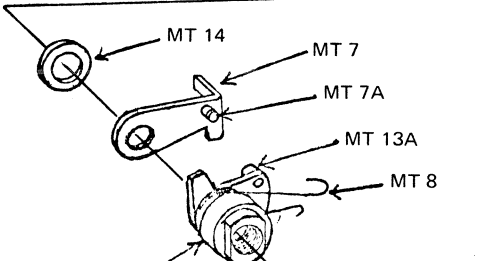
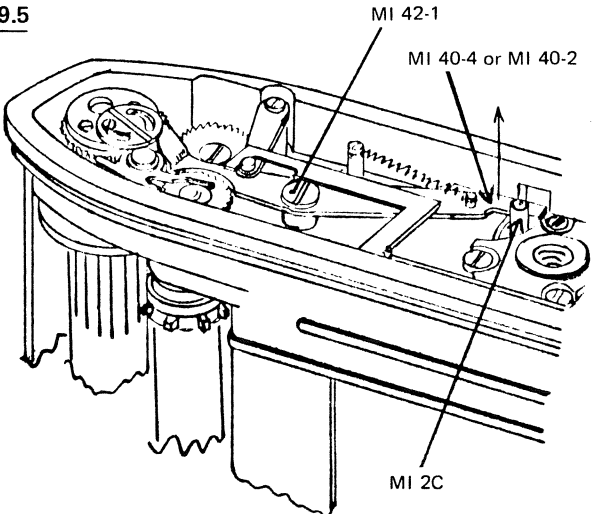
Step No.	Procedure	Illustration
9.1	Remove front cover, Item 1: right cover, Item 2: left cover, Item 3: bottom cover, Item 4: right front cover Item 5: left front cover, Item 6: lens mount assembly, Item 7: mirror housing light baffle, Item 8: as described under the appropriate heading.	<p data-bbox="881 520 967 541"><b>Fig. 9.3</b></p> 
9.2	Release shutter and leave mechanism uncocked.	<b>Fig. 9.4</b>
9.3	Unscrew self-timer shaft by unscrewing screw B 2 x 2.8 x 4.3 x 0.8, and lifting off spring, MT8-2, with parts MT13-4, MT13A, MT7A, MT7 and washer, MT14.	
9.4	Loosen screw, S 1.7 x 3 x 3.5 x 0.8, in MI17-2. Do not remove screw, but simply loosen enough to free lever on MI17-2.	<b>Fig. 9.5</b>
9.5	Loosen, MI42-1, to loosen mirror setting lever, MI40-4, (older type MI40-2) in bottom mechanism. Lift MI40-4 over setting pin MI-2C.	
9.6	In the base of the body are found two variable resistors. Unsolder the thick black wire from its terminal on one of the resistors. Free the wire from the assembly. Then unsolder the two thin wires, black and red, from the resistors.	
9.7	Remove the 2 screws, B 1.4 x 2.8 x 2.4 x 0.8, which hold the meter movement.	

Fig. 9.3

Fig. 9.4

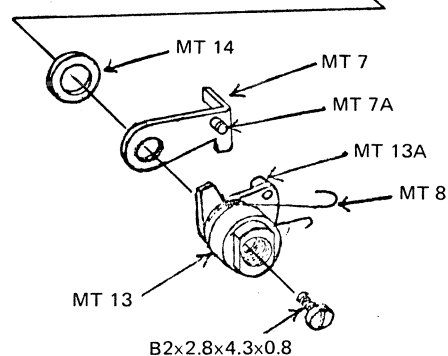
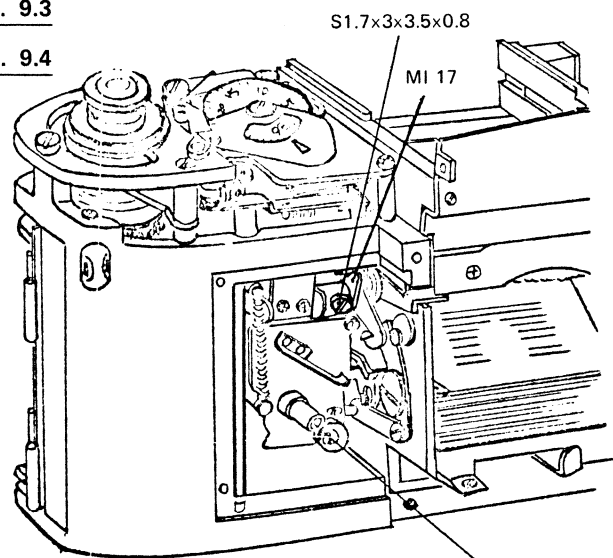
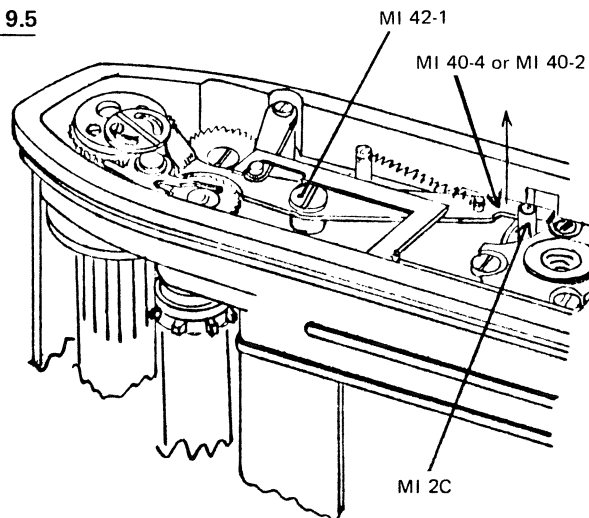
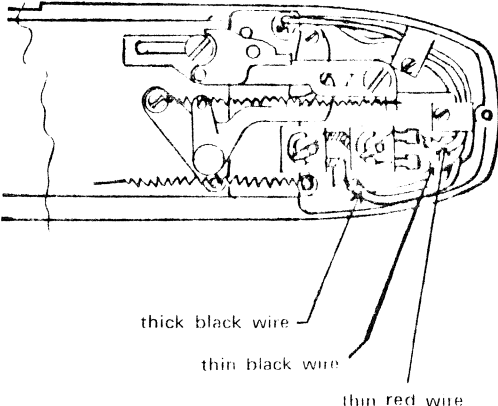
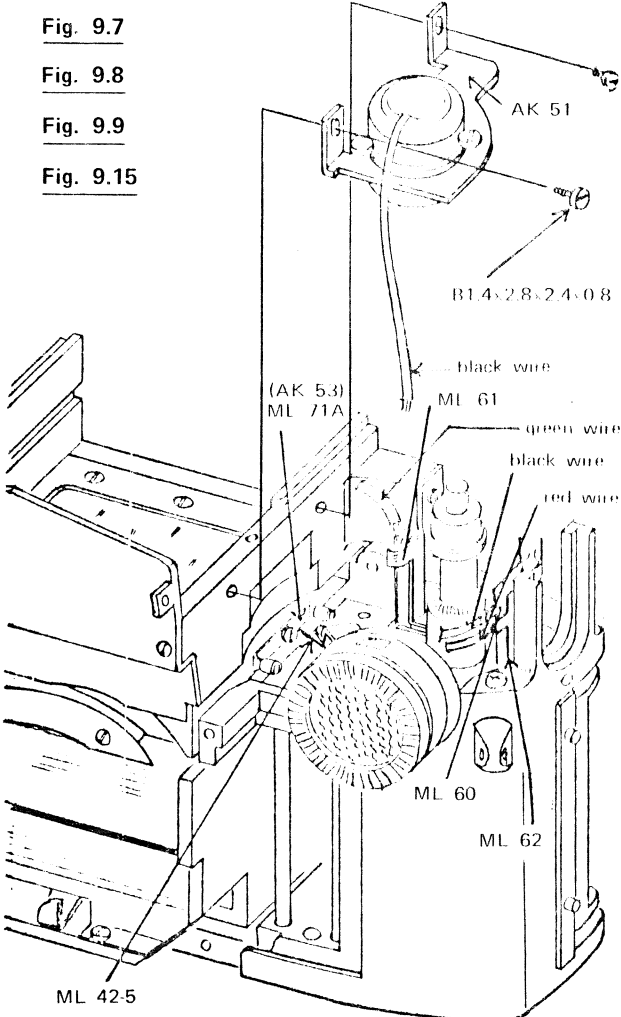


Fig. 9.5



## Section 1 Disassembly

## Item 9 Mirror Housing Assembly – Part No. SK21 (continued)

Step No.	Procedure	Illustration
9.8	<i>Pull the meter movement away from the mirror housing, by lifting slightly to clear the movement from the casting and the ground glass assembly, and pulling the movement away from the mirror housing assembly. The black wire attached to the movement must be held while the movement is being removed from the mirror housing in order to prevent separation of the wire from the movement. Once the movement is clear the black wire should be pulled free of the body. The wire should pull out freely if it has been freed from the base of the body as described in Step 9.6.</i>	Fig. 9.6 
9.9	<i>Unsolder the green wire from ML 61; the red wire from ML 62; and the thick black wire from ML 60.</i>	Fig. 9.7
9.10	<i>Pull the 3 wires around toward the front of the camera to clear them from the mirror housing.</i>	Fig. 9.8
9.11	<i>Remove the 3 screws, S 1.7 x 5.5 x 2.7, from the back of the body.</i>	Fig. 9.9
9.12	<i>Pull the 2 wires, red and thin black, from the body, near the bottom of the mirror housing.</i>	Fig. 9.15
9.13	<i>Lift the counter spring, MC25-1, free from the left side of the mirror housing.</i>	



Section 1 Disassembly

Item 9 Mirror Housing Assembly – Part No. SK21 (continued)

Step No.	Procedure	Illustration
----------	-----------	--------------

9.14 Wind the film advance lever approx. half way.

Fig. 9.11

9.15 Mirror housing should be pushed out of the body by pressing on the rear of the housing and sliding the housing straight out, being careful to clear the follow needle, ML42-5, and meter needle stops, ML71A-3.

Fig. 9.13

Note: It may be necessary to remove the follow needle, ML42-5, in the older style cameras, since the needle is much longer than the present type.

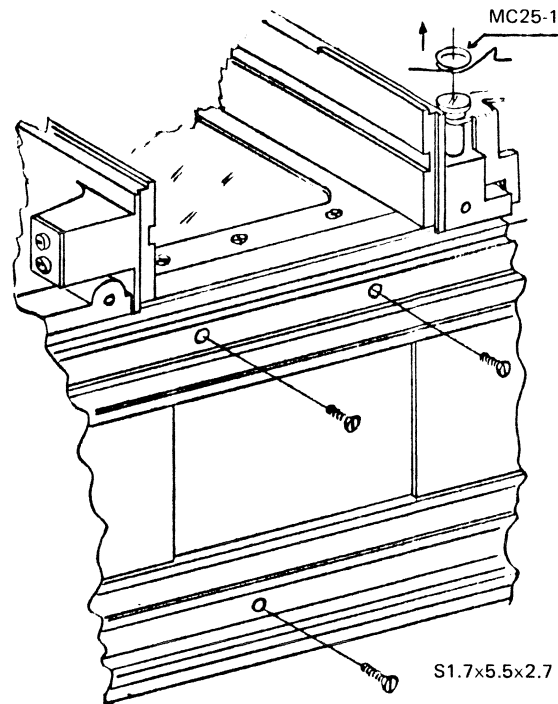
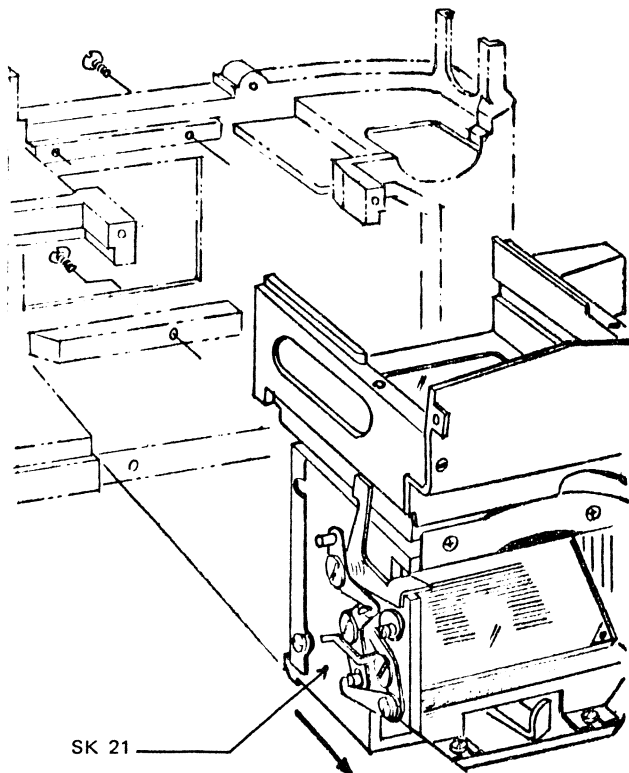


Fig. 9.15





**SECTION 2**  
**ASSEMBLY AND ADJUSTMENT**



Section 2 Assembly and Adjustment

Item 1 Shutter

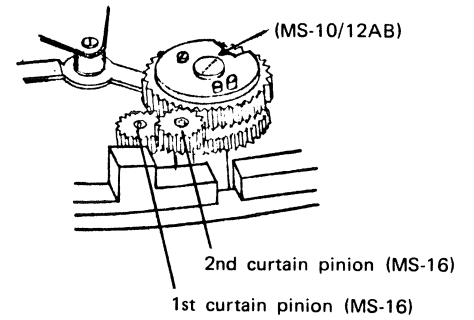
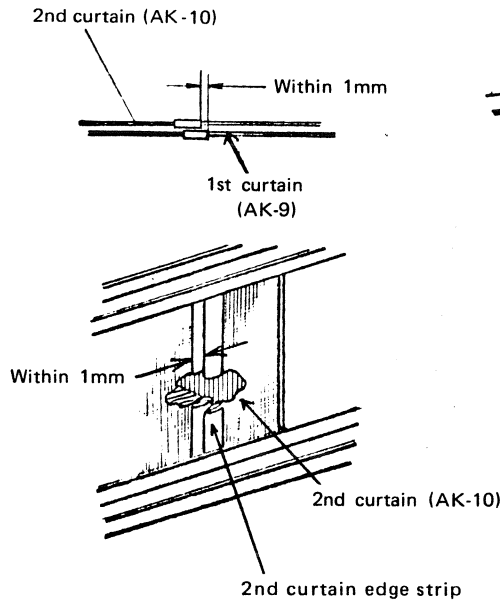
Item	Description	Adjustment Procedure
------	-------------	----------------------

1. Shutter curtain

a.) Gap between two curtains.

The gap should be adjusted to within 1mm.

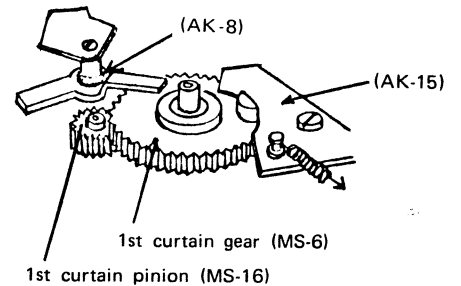
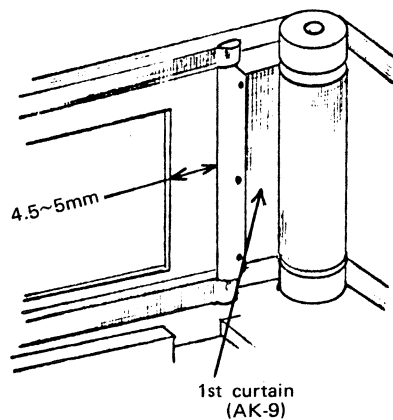
Adjust the gearing of two pinions (MS-16-2) and gear MS-10/12AB)



b.) Starting position of 1st curtain.

It should be adjusted as below;

Adjust the gearing of 1st curtain gear (MS-6) and 1st curtain pinion (MS-16)

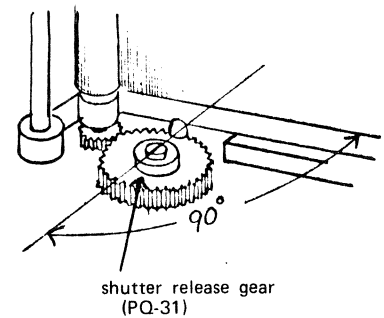


## Section 2 Assembly and Adjustment

### Item 1 Shutter (continued b.) (Starting position of 1st curtain)

b.) Starting position of 1st curtain

Then adjust the shutter release gear (PQ-31) to be  $90^\circ$  when advance lever is fully wound.

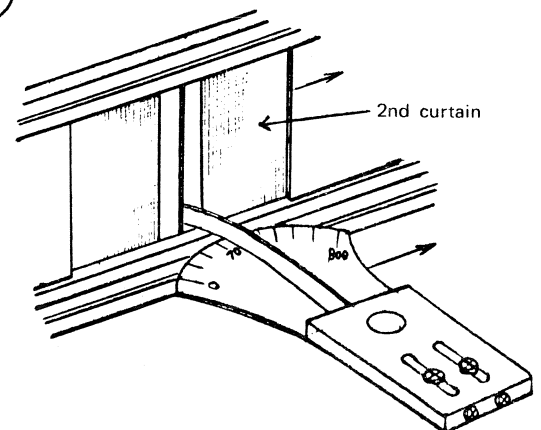
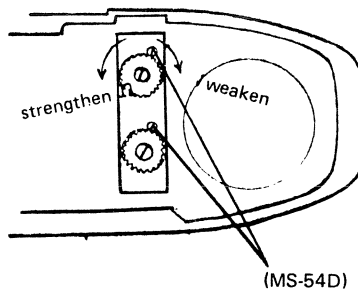


c.) Tension strength of 2nd curtain spring

The tension should be adjusted to between 70g-80g. Normally, it can be obtained by rotating the adjusting pin 2.5-3 times counter-clockwise from the notension position.

Wind the advance lever until the 2nd curtain edge strip is in the center of the picture format.

The 2nd curtain should be opened slightly with the tip of the tension gauge. The tension should now be adjusted by turning the adjusting pin (MS-54D) until the tension gauge indicates a pressure of between 70-80 grms.



## Section 2 Assembly and Adjustment

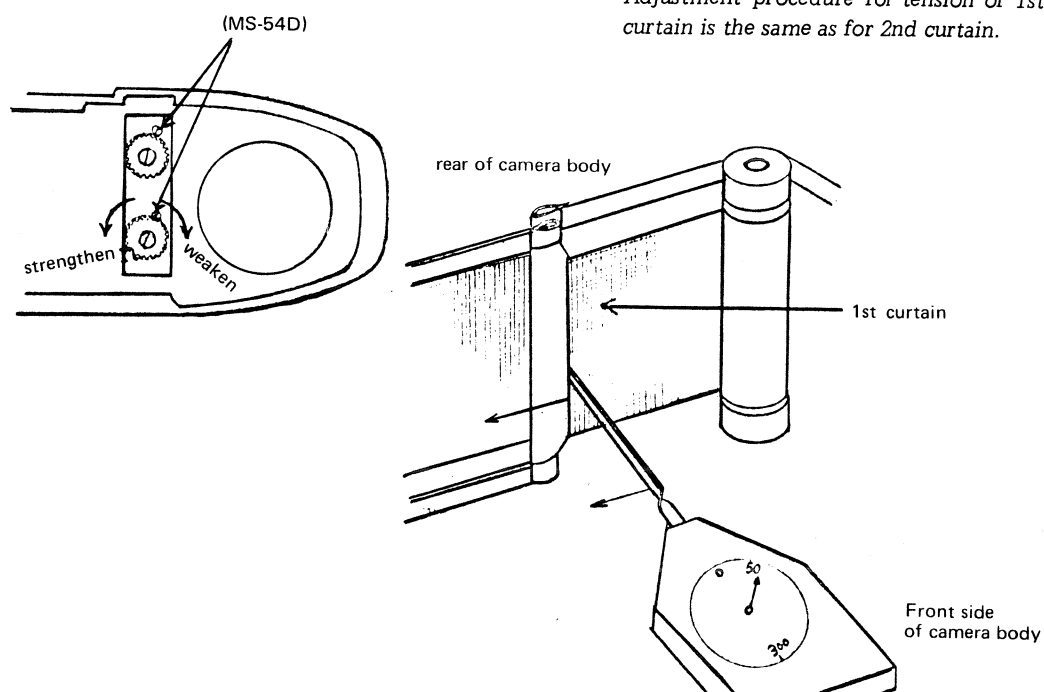
## Item 1 Shutter (continued)

## d.) Tension strength of 1st curtain spring

The tension should be adjusted to between 50-60g.

The tension measurement of 1st curtain should be done from the front side of the camera body.

Adjustment procedure for tension of 1st curtain is the same as for 2nd curtain.



## e.) Curtain travel speed

The speed should be adjusted to be 12.5 millimeters per second for the 34mm travel of the curtain within the picture format.

Adjusting procedure is the same as for the adjustment of curtain spring tension described above.

An electronic shutter speed Tester should be used for calculating the curtain travel speed.

## 2. Shutter exposure speed

a.) Caution

Before starting this adjustment, make sure the curtain tension strength and the speed of curtain travel, (as described previously) are correct.

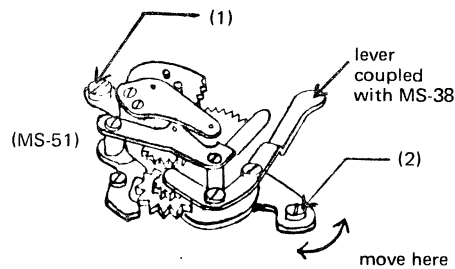
Measurement of curtain travel speed should be done at the speed of 1/1000 sec. or 1/500 sec.

## Section 2 Assembly and Adjustment

## Item 1 Shutter (continued 2.) Shutter exposure speed

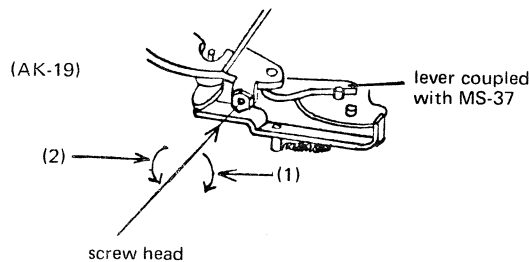
## b.) Adjustment

(1). High speeds 1/1000 sec.



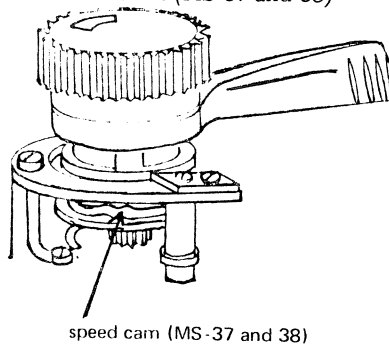
Loosen MS-51B (screws, (1) and (2)) on MS-51 (shutter governor assembly). Make adjustment by moving MS-51 with in the oversized hole on screw (2). Then retighten screws (1) and (2).

(2). Low speeds 1/15 sec.



Adjust by turning screw head which is found on AK-19 in (1) or (2) direction. Direction (1), clockwise, is for prolonging shutter exposure speed. Direction (2), counter-clockwise, is for shortening the shutter speed.

(3). Adjustment of speed cams (MS-37 and 38)



Adjust the contact between cams and levers.

If necessary, reduce the curvature of contact surface on MS-38 by means of filing or scraping with scraping tool. To enlarge curvature, press out the portion to be revised with tweezers.

Remark: Make absolutely sure that the changing-over of gears is made according to the following table. This is because the gears in the governor mechanism vary for each exposure speed.

Shutter speed \ Gear	Segment	1st gear	2nd gear	2nd curtain release lever
1 sec. - 1/15 sec.	engaged	engaged	engaged	engaged
1/30 sec. - 1/250 sec.	engaged	engaged	engaged	not engaged
1/500 sec. - 1/1000 sec.	engaged	engaged	not engaged	not engaged

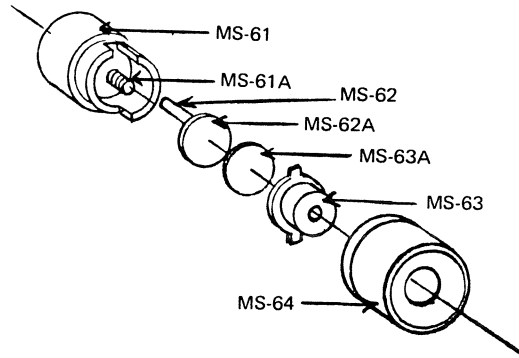


## Section 2 Assembly and Adjustment

## Item 1 Shutter (continued)

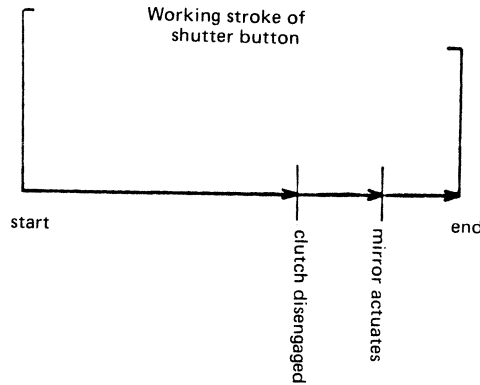
## 3. Shutter button

## a.) Stroke

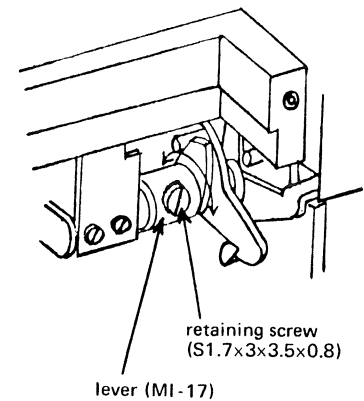


Make adjustment by inserting a spacing washer (MS-63A) under the shutter button (MS-63).

## b.) Timing



Adjust the position of lever (MI-17) by loosening retaining screw, S 1.7 x 3 x 3.5 x 0.8 so as to actuate the mirror shortly after the clutch disengages.



## c.) Pressure of shutter button

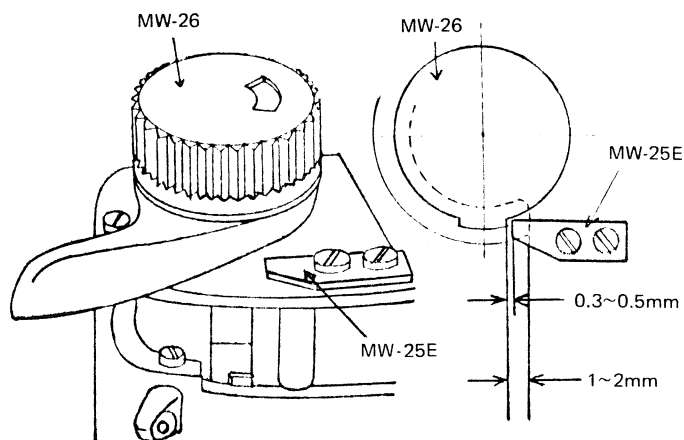
The pressure of shutter button should be adjusted to between 700g-800g.

## Section 2 Assembly and Adjustment

## Item 2 Film Winding

1. Stop plate MW-25E is adjusted with the film winding lever in the fully wound position.

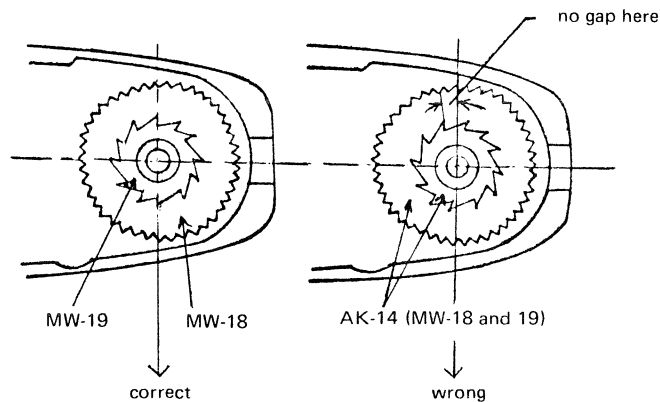
Should be adjusted as below;



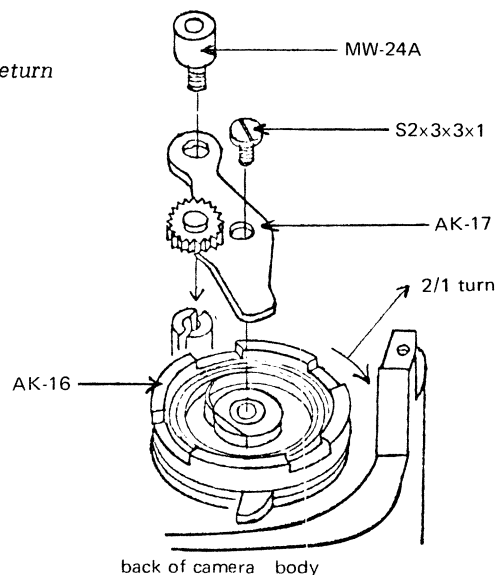
2. Adjustment of winding ratchet (AK-14) is also performed with the film winding lever in the fully wound position.

The gear teeth on MW-19 should coincide with horizontal and vertical lines taken along the length and breadth of the camera body as illustrated. With a line drawn at a right angle to the body line and passing over the center hole of MW-19.

Should be adjusted as follows;

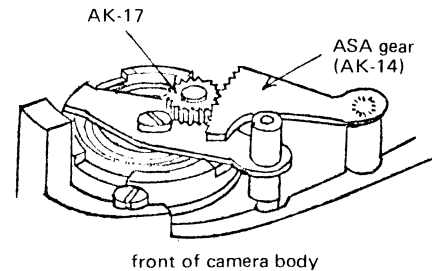


3. Position of lever return spring



The spring may be tightened by turning spring case (AK-16) approx.  $\frac{1}{2}$  turn clockwise and assembled with AK-17 onto the body.

Then adjust the gearing of ASA gear (AK-14-1) and AK-17 so as to engage smoothly.



Section 2 Assembly and Adjustment

Item 2 Film winding (continued)

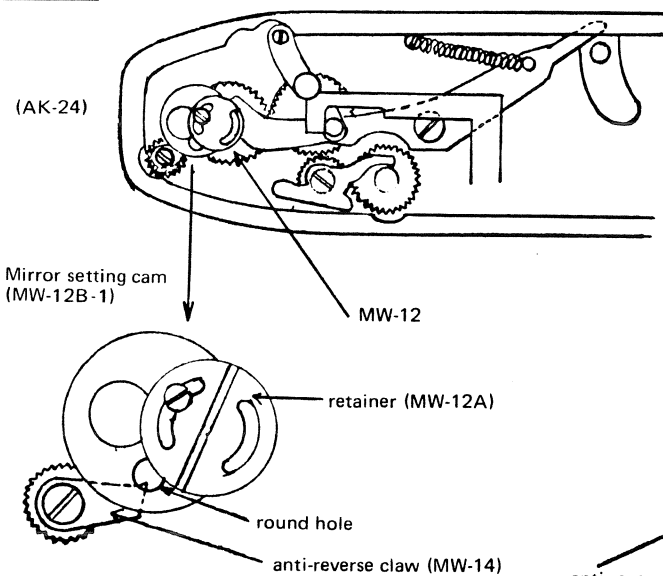
4. Position of mirror setting lever gear (AK-24)

Adjust the anti-reverse claw until the tip is just visible through a small round hole in the mirror setting cam (MW-12B-1).

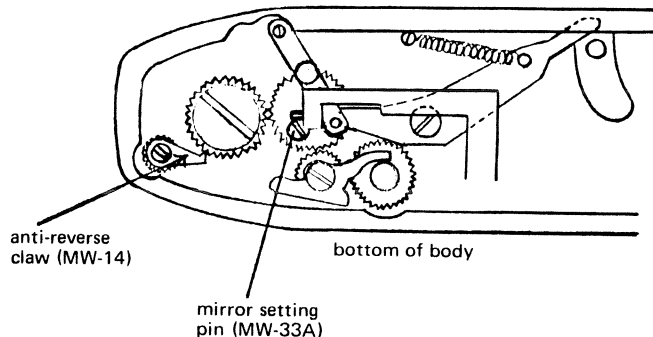
In older models, the mirror setting cam and retainer (MW-12A) may not exist.

In such cases, adjustment can be made by replacing the pin on MW-33A with a pin that has an appropriate size head.

Current models

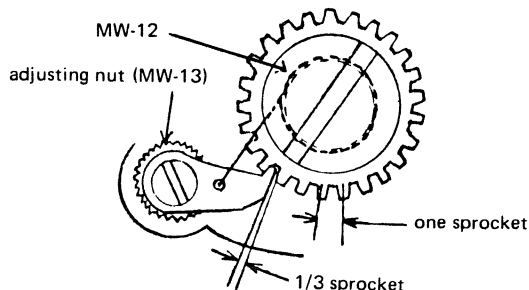


Old models



5. Anti-reverse claw

With anti-reverse claw (MW-14) fully wound, turn adjusting nut (MW-13) so as to give 1/3 of a sprocket amount of play when measured at the tip of the claw.

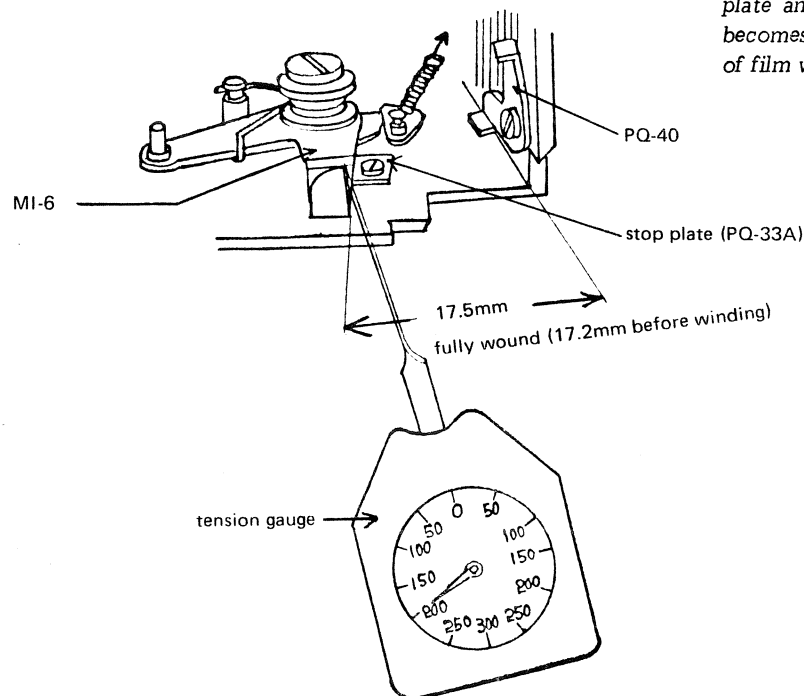


## Section 2 Assembly and Adjustment

## Item 2 Film winding (continued)

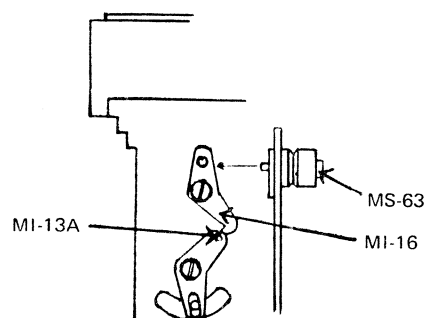
## 6. Position of diaphragm lever

Make adjustment by changing the position of the square stop plate with an eccentric center hole, so that the distance between the outer edge of the square plate and mirror adjusting lever (PQ-40) becomes 17.5mm at fully wound position of film winding lever.



## 7. Spring tension of diaphragm lever

After making the previous adjustment, push shutter button (MS-63) without turning the film winding lever. The connection between lever (MI-16) and a stud (MI-13A) on connecting lever (MI-13) should now release.



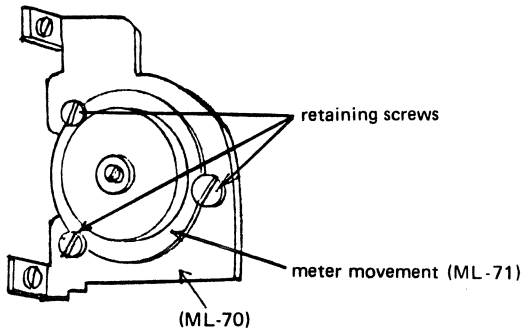
Measure the tension by pressing the diaphragm lever (MI-6) slightly with the tip of the tension gauge. The tension strength should be between 180 grms and 220 grms.

Section 2 Assembly and Adjustment

Item 3 Exposure Meter

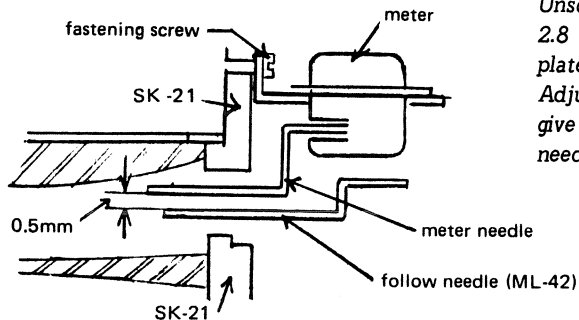
1. Adjustment of meter

a.) Zero position



Make adjustment by changing the position of meter movement (ML-71) on the base plate (ML-70) after unfastening three retaining screws (B 1.4 x 2.5 x 3 x 0.8).

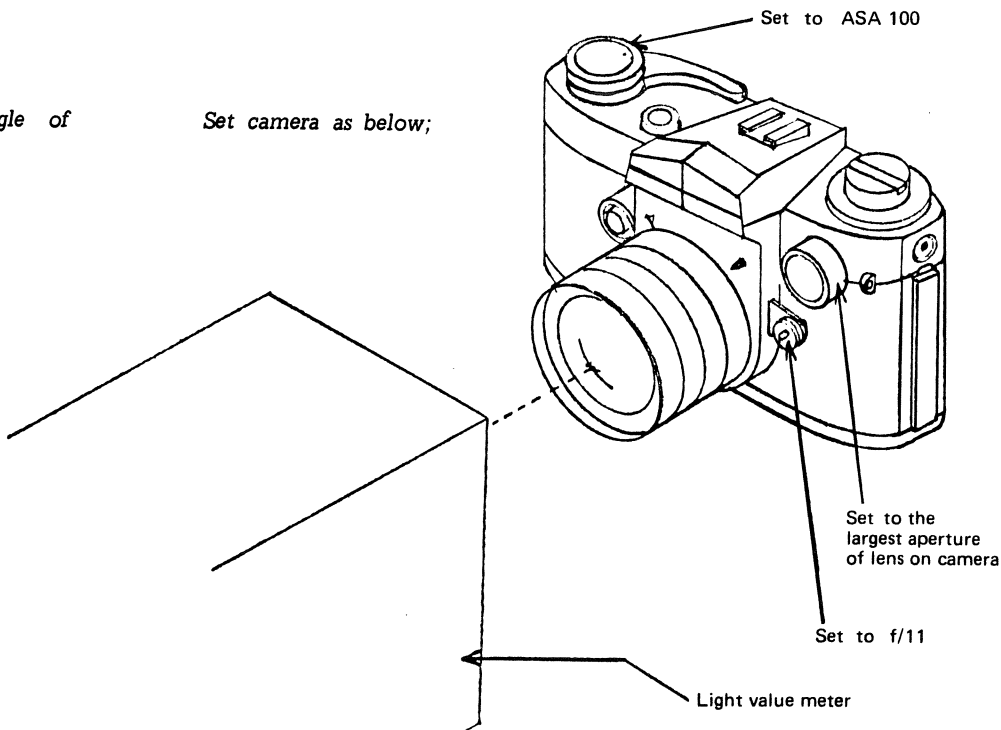
b.) Distance between meter needle and follow needle



Unscrew two fastening screws (B 1.4 x 2.8 x 2.4 x 0.8) attaching meter base plate onto mirror housing (SK-21). Adjust the height of fastening position to give a gap of 0.5 mm between the two needles.

c.) Deflection angle of meter needle

Set camera as below;



## Section 2 Assembly and Adjustment

## Item 3 Exposure Meter (continued 1. Adjustment of meter c.) Deflection angle of meter needle)

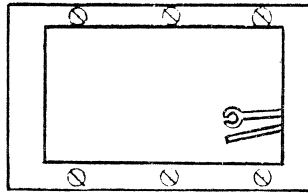
c.) Deflection angle of meter needle (continued)

Watch carefully the deflection of meter needle through the viewfinder when changing the shutter exposure speed of camera when exposed to the intensity of light from the light value meter.

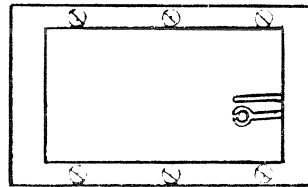
Then make adjustments so that the meter needle overlaps the follow needle.

c-1.) Low intensity

Set as follows;  
shutter speed: 1 sec.  
intensity of light: EV 7



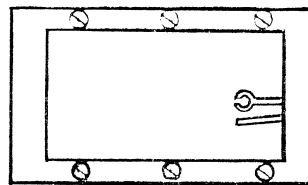
If the meter needle deflects below the follow needle, replace the meter (ML-71) or Cds cell.



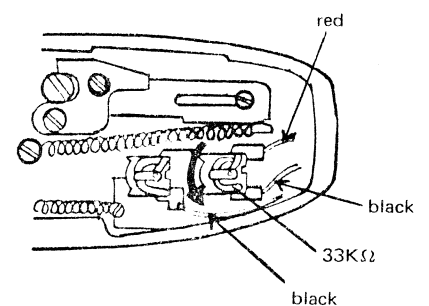
If the meter needle deflects beyond the follow needle, there is a defect in the follow needle (ML-42-3) mechanism.

c-2.) Medium intensity

Set as follows;  
shutter speed: 1/15 sec.  
intensity of light: EV 11



If the meter needle deflects below the follow needle, change resistance of variable resistor  $33K\Omega$  ( $69C$ ) as shown below.



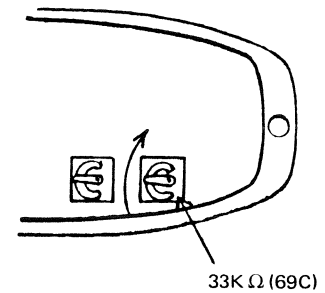
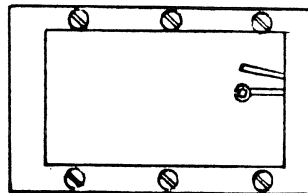
## Section 2 Assembly and Adjustment

## Item 3 Exposure Meter (Continued 1. Adjustment of meter c.) Deflection angle of meter needle

c.) Deflection angle of meter needle (continued)

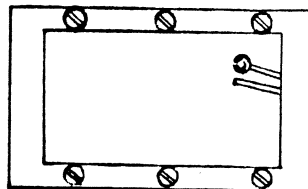
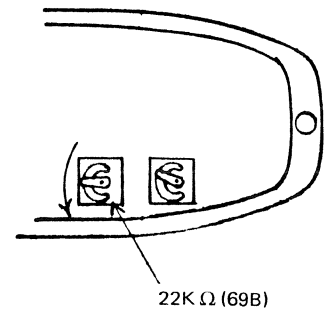
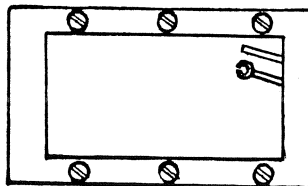
c-2.) Medium intensity (continued)

If the meter needle deflects beyond the follow needle, adjust the resistor by turning contact in clockwise direction as shown below.

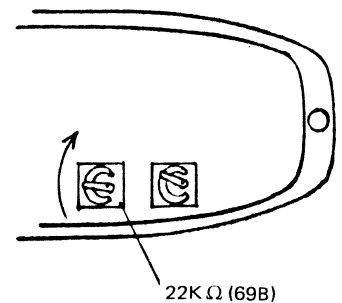


c-3.) High intensity  
Set as follows;  
shutter speed: 1/250 sec.  
intensity of light: EV 15

If the meter needle deflects below the follow needle, adjust resistor 22K Ω (69B) in a counter-clockwise direction.



If the meter needle deflects beyond the follow needle, adjust the resistor 69B as below, in a clockwise direction.



## Section 2 Assembly and Adjustment

## Item 3 Exposure Meter (continued)

## 2. Follow needle

The follow needle should be adjusted to indicate the "O" position when following settings are provided.

ASA 100

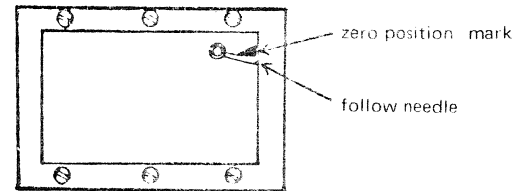
shutter speed: 1 sec.

diaphragm: widest

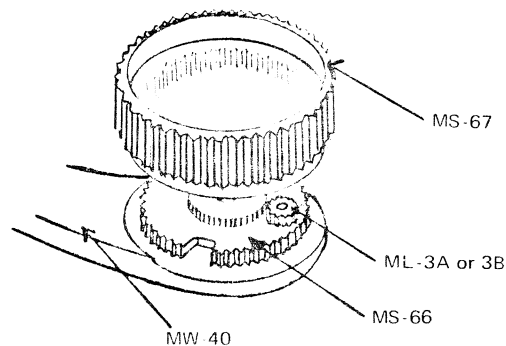
lens aperture: widest

(Lens to be standard 50mm)

"O" position of follow needle  
(Within triangular zero position indicator.)



## 3. ASA dial Adjustment



Set both diaphragm and lens aperture to f.8.

Remove two screws in top section of shutter speed knob and remove ring MS-67, cover, spring, and small gear ML-3A or 3B.

With the lens and aperture set at f.8 the ASA dial should be rotated counter clockwise against its spring until the follow needle shows a slight movement. This is the correct position for ASA 100 and ASA 100 should be in a central line drawn down the length of the body. If the ASA dial shows another ASA speed it is incorrect and should be rotated clockwise until it stops. The ASA dial should now be lifted slightly and compensation made for the difference in reading. This operation should be performed until ASA 100 is indicated by the slight movement of the follow needle and in a central line drawn down the body of the camera.



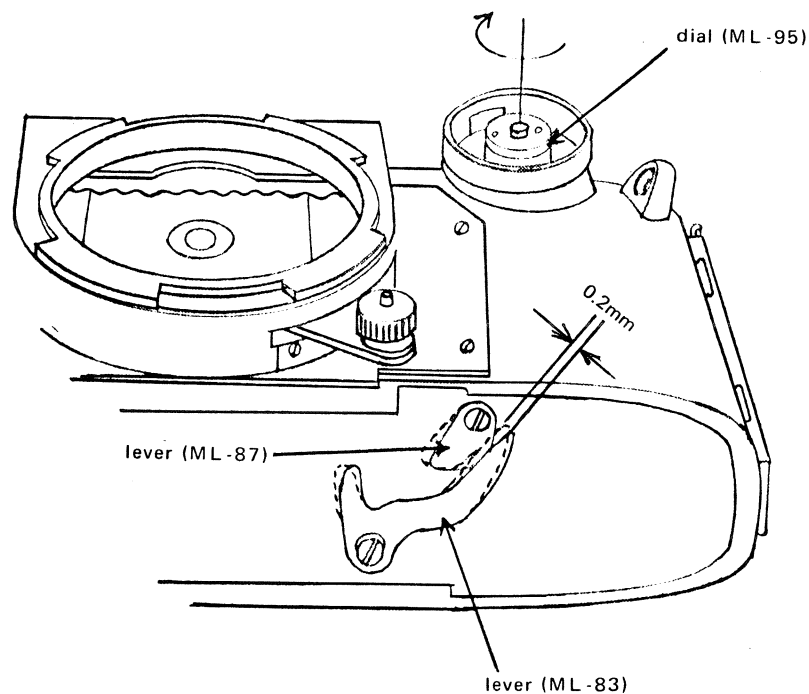
## Section 2 Assembly and Adjustment

## Item 3 Exposure Meter (continued)

## 4. Lens aperture dial

If there is a gap between the two levers (ML-87 and ML-83) when dial (ML-95) is turned fully clockwise, turn the dial (ML-95) in a counter clockwise direction and secure it in a position where lever (ML-83) is moveable for approx. 0.2mm.

In this position, the dial (ML-95) should indicate widest aperture when dial scale is re-mounted.



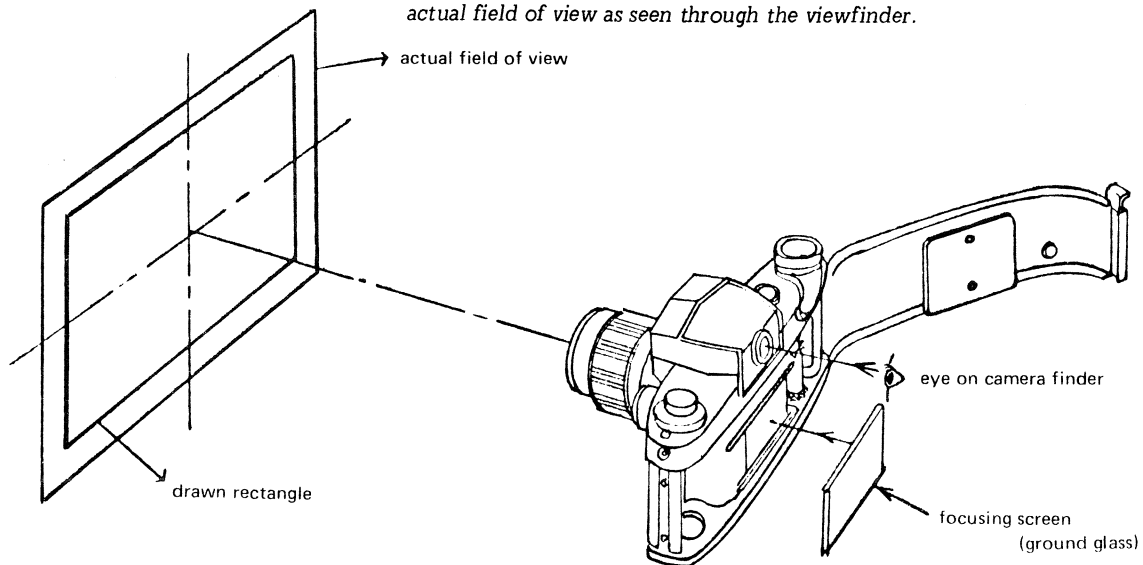
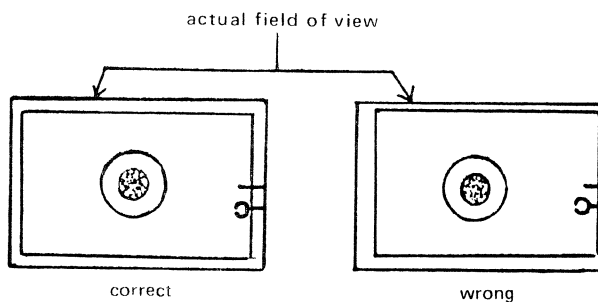
## Section 2 Assembly and Adjustment

## Item 4 Mirror

## 1. Fitting position

Preparation for adjustment: Set the distance scale ring of mounted lens to the closest focusing distance.

Put a piece of white paper on the wall and draw a slightly smaller rectangle than the actual field of view as seen through the viewfinder.

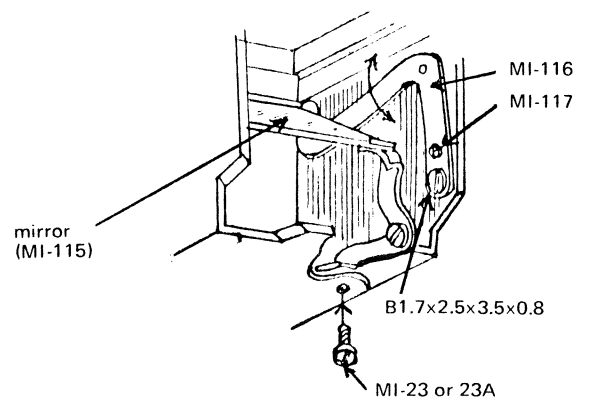
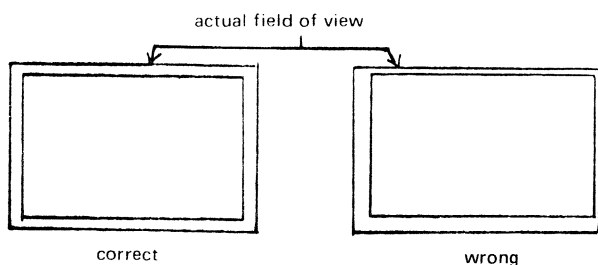
Image through camera finder

Adjustment: Set the shutter speed to B, and open the shutter.

Then adjust the mirror so that both images, viewed through camera finder and focusing screen, become a well proportioned double rectangle as shown in the left figure.

Mirror can be adjusted as follows;

- 1.) Unfasten screw B 1.7 x 2.5 x 3.5 x 0.8. Then turn the eccentric screw (MI-177) for horizontal adjustment.
- 2.) Turn the screw (MI-23 or 23A) to alter mirror angle and correctly position viewed rectangle.

Image on focusing screen

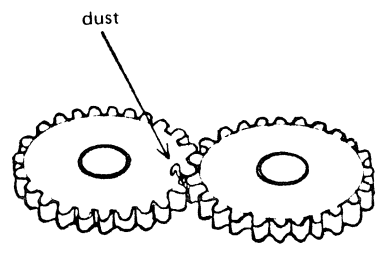
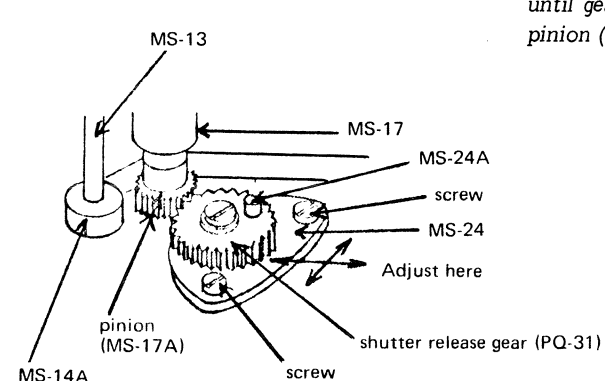
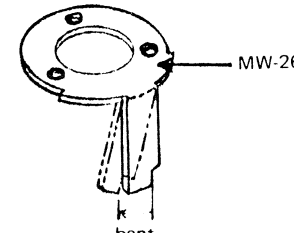
**SECTION 3**  
**MALFUNCTION SYMPTOMS AND REPAIR GUIDE**

---



## Section 3 Malfunction Symptoms and Repair Guide

## Item 1 Shutter

Item	Symptoms	Repair Instructions
1. Curtain	a.) <i>Dust or metal chips between gears</i>	<i>Remove dust or other foreign bodies. Readjust gears.</i>
		
	b.) <i>Loose or incorrect positioning of release gear (PQ-31).</i>	<i>Loosen two screws (B 1.7 x 3.3 x 3.5 x 0.8) and adjust the position of the release gear (PQ-31) by moving the base plate (MS-24) back and forth or right and left, until gear (PQ-31) engages correctly with pinion (MS-17A).</i>
		
	c.) <i>Insufficient pressure of shutter button</i>	<i>Refer to previous instruction described on page 16.</i>
	d.) <i>Insufficient turning of film winding lever</i>	
	(1) <i>Bent intermediate lever (MW-26)</i>	<i>Remove right cover (SK-32). Remove and replace the film winding lever (MW-26) from the lower assembly of the film winding mechanism.</i>
		

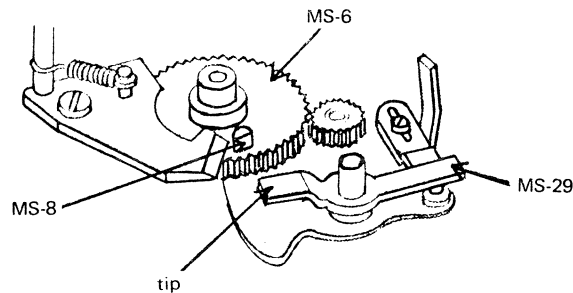
## Section 3 Malfunction Symptoms and Repair Guide

## Item 1 Shutter (continued)

## 1. Curtain (continued)

- (2) Release lever (MS-29)  
failure

Adjust the tip of the lever so that it interlocks properly with the coupler stud (MS-8) of the 1st. curtain gear (MS-6).



- (3) Shutter release gear  
(PQ-31) sticks

Refer to the previous instruction described on Page 26.

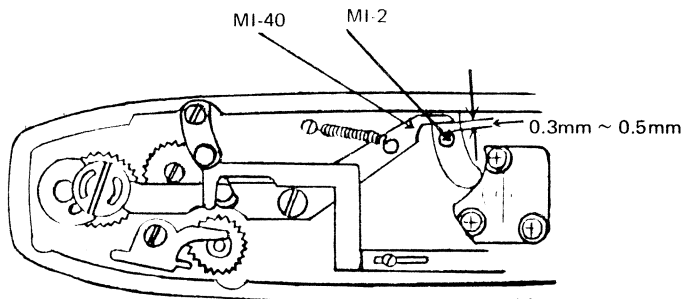
- (4) Dust or metal chips  
between gears

Remove dust and metal chips and re-adjust.

## 2. Mirror Housing

- a.) Incomplete stroke of mirror  
setting lever

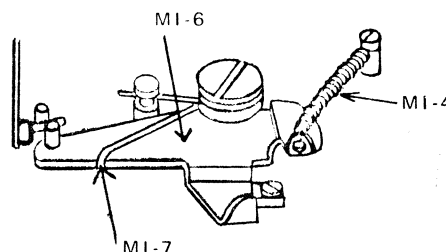
Adjust the stroke by bending the tip of the lever (MI-40) in the bottom mechanism. It should provide an adequate gap of 0.3-0.5mm with the stud (MI-2) when the shutter is released.



- b.) Weakening of springs,  
MI-7 and/or MI4.

Replace all weak springs. Refer to Page 19 for adjustment instructions using the tension gauge.

Note: Weakening of springs MI-7 & MI-4 can cause the mirror to hit Lever MI-46-3 too lightly, thereby not allowing the shutter to be released or not allowing the diaphragm to reopen to its maximum opening.



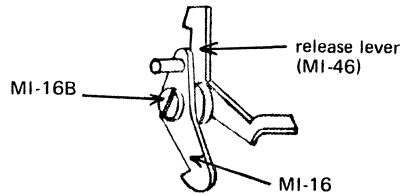
Section 3 Malfunction Symptoms and Repair Guide

Item 1 Shutter (continued)

2. Mirror Housing (continued)

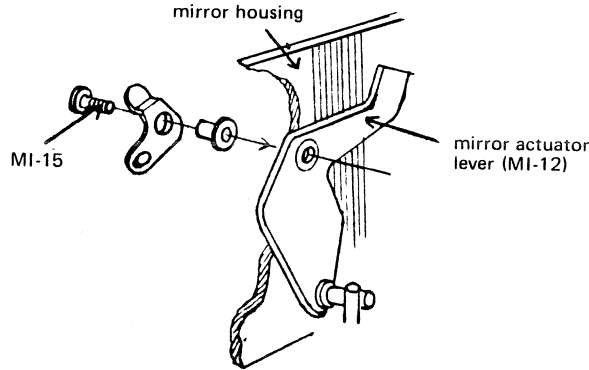
c.) Loose release lever (MI-46)

Adjust by tightening retaining screw (MI-16B)



d.) Loose mirror actuator lever (MI-12)

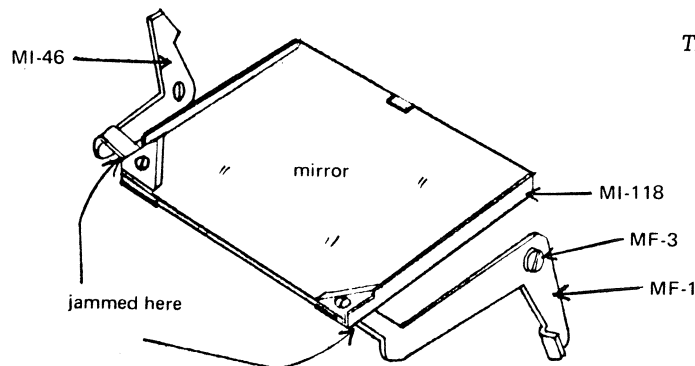
Adjust by tightening the retainer screw (MI-15). If necessary, apply an adhesive bond to ensure that it stays tight.



e.) Mirror frame jammed

Free the mirror frame (MI-118) from levers (MI-46 & MF-1) by loosening screw (MF-3).

Then re-tighten screw (MF-3).



## Section 3 Malfunction Symptoms and Repair Guide

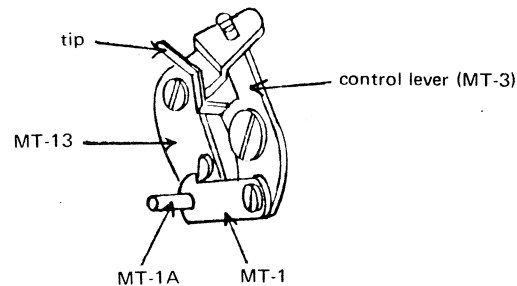
## Item 1 Shutter (continued)

## 3. Self-timer

1. Self-timer does not operate

- a.) Failure of the lever (MT-3)

Adjust lever (MT-3) by bending the tip until it engages with one of the gears in the self-timer assembly.



Note: If self timer does not complete it's action it should be washed in carbon tetrachloride or similiar cleaning fluid.

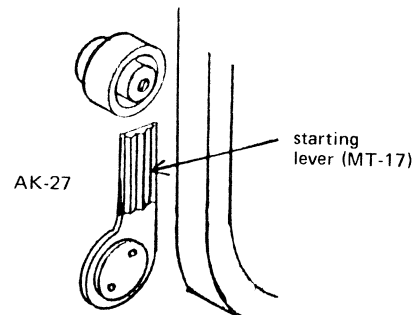
- b.) Defect in selftimer

Replace the self-timer assembly (AK-25).

2. Self-timer operates incorrectly

- a.) Starting lever operates incorrectly

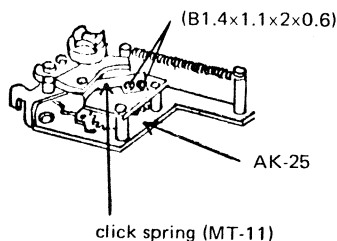
This malfunction is mainly caused by sticking between control lever (MT-3) and its gear.



Free lever (MT-3) from its gear, and re-adjust the connection following the previous instructions in 3-a.

- b.) Click spring (MT-11) not operating

Remove two screws (B 1.4 x 1.1 x 2.0 x 0.6), and replace spring (MT-11).





## Section 3 Malfunction Symptoms and Repair Guide

## Item 1 Shutter (continued)

## 4. Exposure speed

1. Too slow at high shutter speeds

a.) 1st curtain too fast

Refer to Page 14 (1d) and adjust curtain tension accordingly.

b.) 2nd curtain too slow

Refer to Page 13 (1c) and adjust curtain tension accordingly.

c.) Governor does not operate properly (too sluggish)

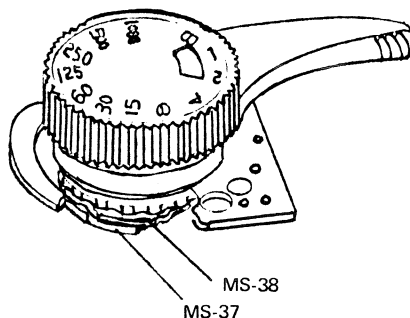
Refer to Page 15 (1b) and adjust the governor mechanism (MS-51).

If necessary, replace the governor assembly (MS-51).

d.) Defect in speed cams (MS-37, 38)

Refer to Page 15 (1b).

If necessary, replace cams (MS-37 and/or 38).

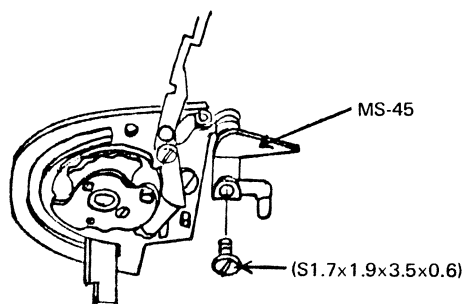


e.) Governor lever does not operate properly (MS-45).

After removing right cover (SK-40), also remove three screws (MC-23, S 1.7 x 1.8 x 3 x 0.8 and S 1.7 x 3.5 x 3 x 0.8) and take off counter base plate assembly (AK-28).

Then remove film winding assembly (AK-19) by removing three screws on the base plate.

Remove underneath retaining screw (S 1.7 x 1.9 x 3.5 x 0.6) and replace the lever (MS-45).



### Section 3 Malfunction Symptoms and Repair Guide

#### Item 1 Shutter (continued)

#### 4. Exposure speed (continued)

##### 2. Too fast at high shutter speeds

a.) 1st curtain too slow

Refer to Page 14 (1d) and adjust curtain tension.

b.) 2nd curtain too fast

Refer to Page 13 (1c) and adjust curtain tension.

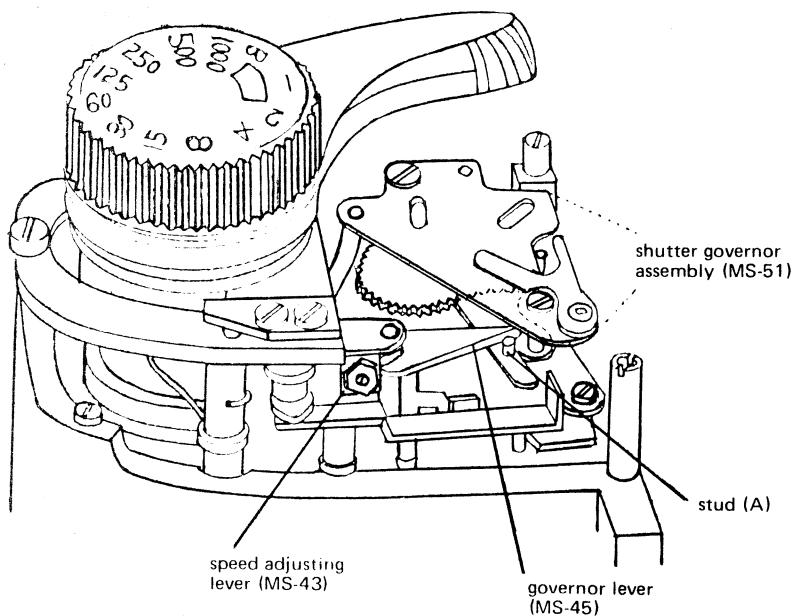
c.) Governor does not operate properly (too light)

Refer to Page 15 (1b) and adjust the governor mechanism so that it engages properly with its associated parts.

If necessary, replace the governor assembly (MS-51).

d.) Defect in speed cams

Refer to Page 15 (1b). for repair instructions.



Note: Wash MS-51 in carbon tetrachloride or similar cleaning fluid if shutter is too slow at slow shutter speeds as described in No. 3 below before replacing governor MS-51.

##### 3. Too slow at low shutter speeds

a.) Governor does not operate properly (too heavy)

Refer to Page 15 (1b) and adjust the governor (MS-51) accordingly.

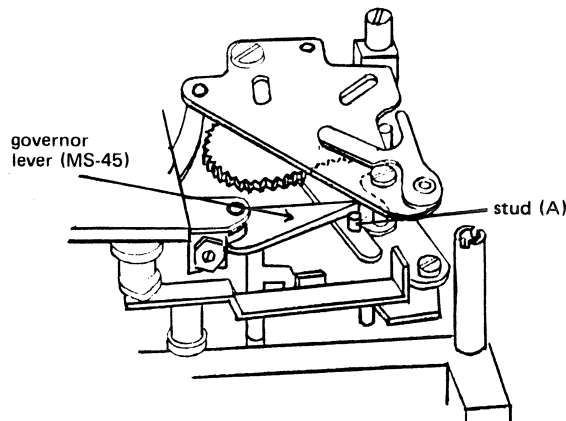
If necessary, replace the governor assembly (MS-51).

## Section 3 Malfunction Symptoms and Repair Guide

## Item 1 Shutter (continued)

3. Too slow at low shutter speeds (continued)

- b.) Governor lever (MS-45) jammed



Refer to previous instruction on Page 30 (e).

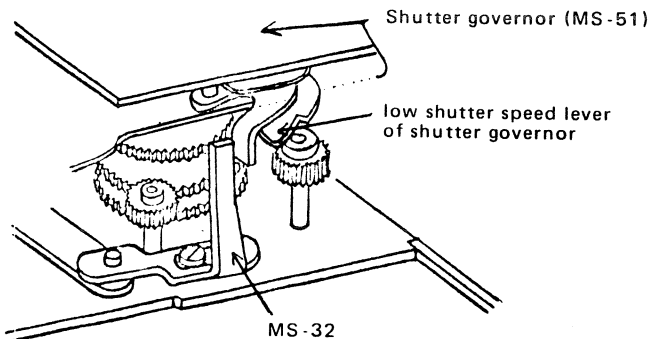
Ensure that the side surface of lever (MS-45), where it contacts stud (A) is smooth.

Then adjust all gears within the governor assembly (MS-51) to ensure proper operation.

4. Too fast at low shutter speeds

- a.) Governor does not operate properly

- A) When fully wound (shutter cocked)

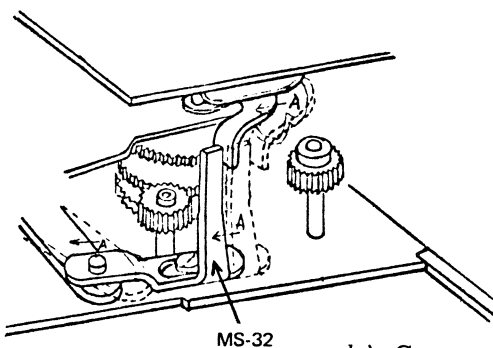


Refer to Page 15 and adjust the governor accordingly.

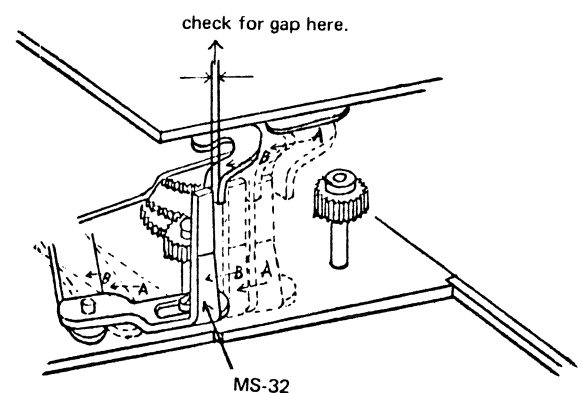
Check the complete performance of relay lever (MS-32) with regard to the coupling and release point with low shutter speed lever of the shutter governor (MS-51). Refer to illustration.

If necessary, replace the governor assembly (MS-51) following the instructions described on Page 30 (e).

- B) Position when shutter release button pressed about half way.



- C) Shutter released position.



- b.) Governor lever (MS-45) defaced and loosely operating.

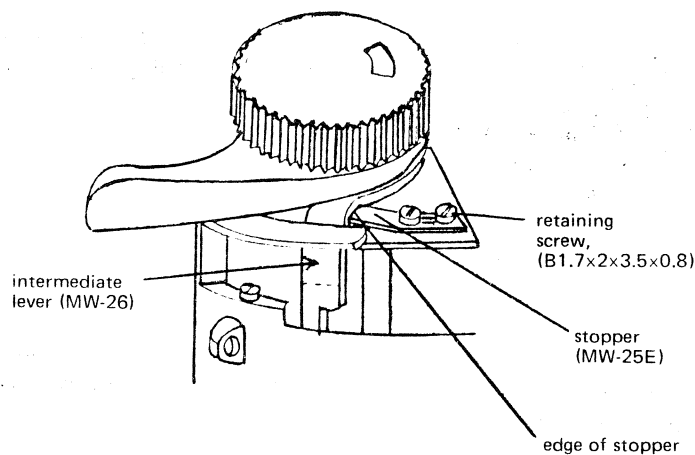
Replace the lever (MS-45) in the same manner as previously described on Page 30 (e) and adjust.

## Section 3 Malfunction Symptoms and Repair Guide

## Item 1 Shutter (continued)

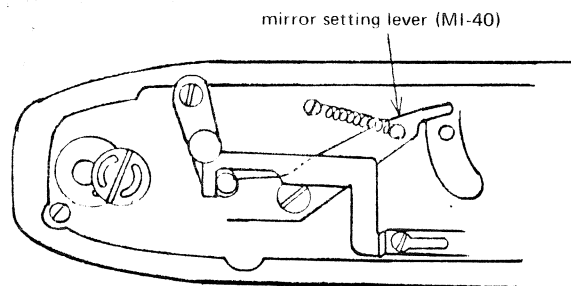
5. Shutter curtain travels without completing a slit

- a.) Winding lever does not operate completely



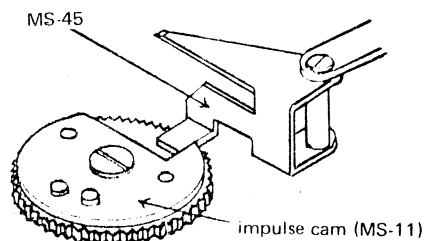
Adjust the halt position of stopper (MW-25E) against intermediate lever (MW-26) by loosening two retaining screws (B 1.7 x 2 x 3.5 x 0.8), so that the edge of the stopper is correctly positioned to stop the intermediate lever at the completion of shutter setting. (For the adjustment, refer to Page 17 (1).

If the intermediate lever is defective, replace it by following the instructions as described at bottom of Page 26.



Alternatively, adjust the stroke of the mirror setting lever (MI-40) following the previous instructions described on Page 27 (2a).

- b.) Governor lever (MS-45) does not operate sufficiently



Adjust the connecting position of governor lever (MS-45) and impulse cam (MS-11) by adjusting the play in the fitting portion of governor lever (MS-45). Make sure of a proper connection. Connecting depth differs for each shutter speed, therefore, the adjustment should be made at all speeds.

- c.) Governor does not operate properly

Refer to Page 15 (1b) and adjust the governor mechanism accordingly.

Section 3 Malfunction Symptoms and Repair Guide

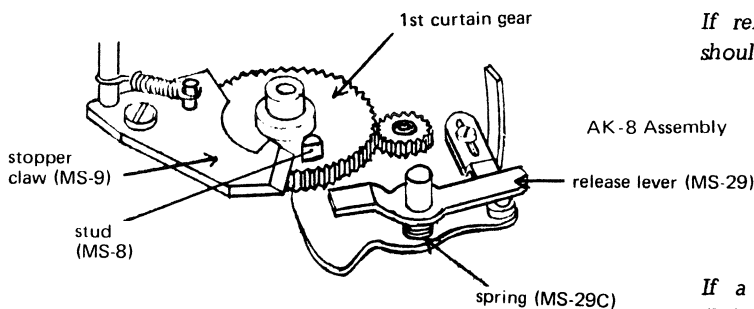
Item 1 Shutter (continued)

5. Shutter curtain travels without completing a slit (continued)

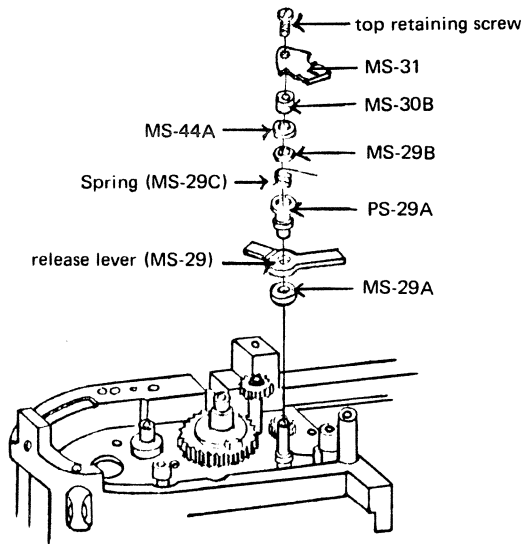
d.) Incomplete operation of release lever (MS-29).

With the winding lever fully wound, adjust lever (MS-29) so that it engages and holds both stud (MS-8) and stopper claw (MS-9).

If release lever (MS-29) is defective it should be replaced.



If a weakening of release lever spring (MS-29C) is found, replace the spring by removing top retaining screw (S 1.7 x 3 x 2.4).



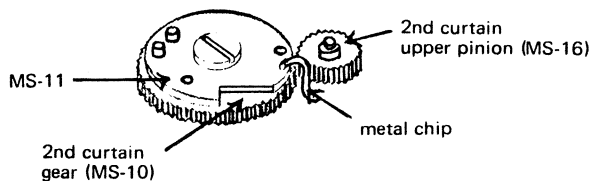
When re-assembling make sure that all parts as illustrated at left, are replaced and aligned on a correct axis to ensure proper functioning.

6. 2nd curtain does not close

a.) Dust or metal chips between gears

Clean away foreign matter and adjust the gearing.

(1)



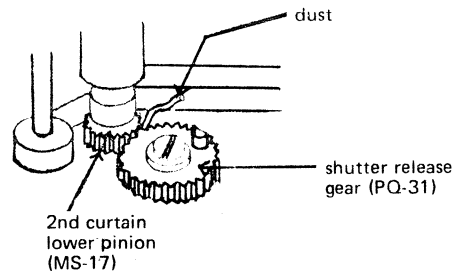
Section 3 Malfunction Symptoms and Repair Guide

Item 1 Shutter (continued)

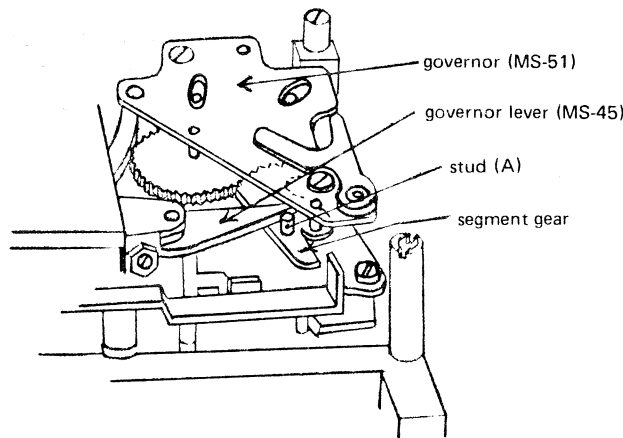
6. 2nd curtain does not close (continued)

a.) Dust or metal chips between gears (continued)

(2)



b.) Defect in governor (MS-51)



Check the movement of the segment gear in the governor assembly. A stud on the segment gear should actuate the governor lever (MS-45).

If the movement of the segment gear is not enough to actuate governor lever (MS-45), then replace the governor assembly (MS-51) following previous instructions on Page 30 (e).

c.) Insufficient operation of governor lever (MS-45).

Refer to previous instructions on Page 32 (3b).

If necessary, replace lever (MS-45) following the previous instructions on Page 30 (e). 4-1-e.

d.) Loose or incorrect positioning of release gear (PQ-31).

Refer to Page 26 (1b) and readjust the connection between the gears.

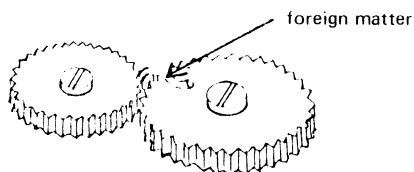
## Section 3 Malfunction Symptoms and Repair Guide

## Item 2 Winding

1. Winding lever fails to turn, but shutter operates

a.) Dust or metal chips between gears

Remove foreign matter and clean gears.

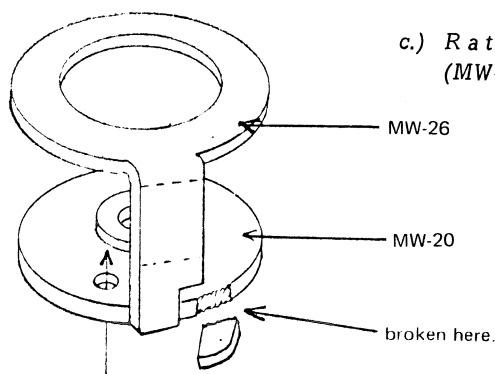


b.) Intermediate lever (MW-26) bent

Replace the lever, following previous instructions on bottom of Page 26.

c.) Ratchet wheel (MW-20) broken

Replace the wheel (MW-20) as follows:

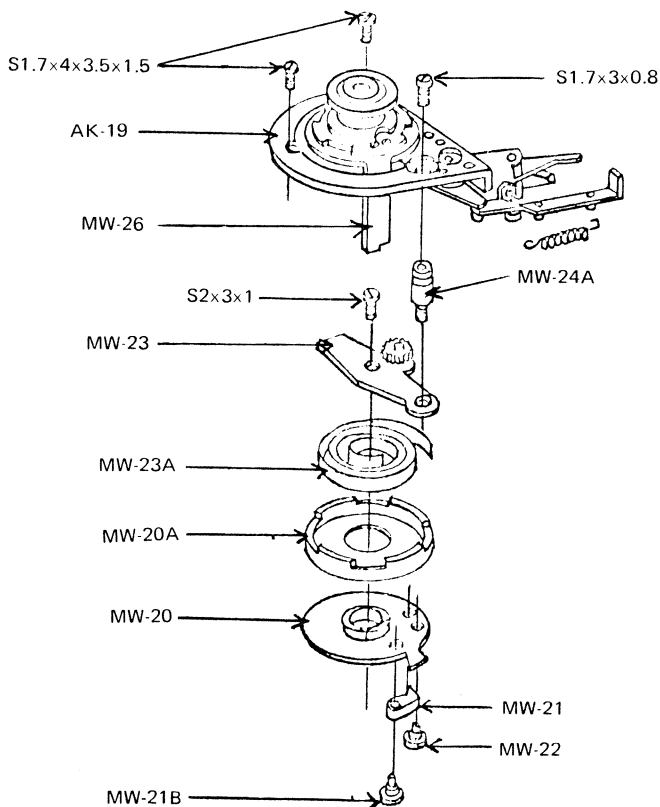


1. Remove right cover, SK 32 (see page 2.)

2. Take off winding assembly (AK-19) by removing three retaining screws (two pcs. of S 1.7 x 4 x 3.5 x 1.5 and one piece of S 1.7 x 3 x 0.8) from base plate of winding assembly (AK-19).

3. Remove screw (S 2 x 3 x 1), and take off bearing shaft. (MW-24A). Then remove spring holder (MW-23), spring case (MW-20A) with spring (MW-23A).

4. After removing winding claw (MW-21), retaining screw (MW-21B) and caulking pin (MW-22), the ratchet wheel (MW-20) can now be replaced.



## Section 3 Malfunction Symptoms and Repair Guide

## Item 2 Winding (continued)

1. Winding lever fails to turn, but shutter operates (continued)

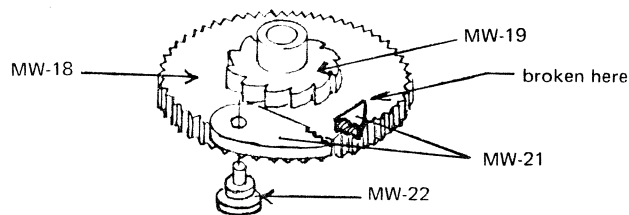
d.) Winding claw (MW-21) broken or operates improperly

Replace the claw (MW-21) as described on Page 36.

e.) Improper gearing of winding ratchet gear (MW-19)

Adjust the gears to effect correct contact.

If necessary, replace the gears (MW-19)  
Note: MW-18 cannot be changed separately. It is available only as assembly AK-14. The winding ratchet gear (MW-19) is located underneath the ratchet wheel (MW-20).

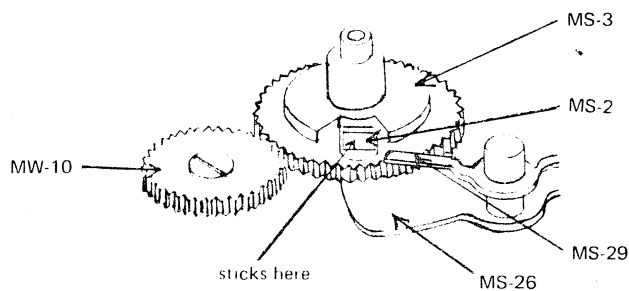


f.) Clutch sticks

Dismantle winding assembly, AK-19 (see Page 36) and shutter governor. MS-51 (see Pages 15 & 30).

Free the clutch (MS-2) by pressing down with a screw driver. Check and adjust the entire clutch operation on clutch (MS-2), clutch gear (MS-3) and clutch plate (MS-26).

If the clutch does not yield to pressure, dismantle the parts (MS-2 and MS-3) by removing the retaining screw (2 x 2.5 x 0.8) on the top of the assembly and replace all defective parts.



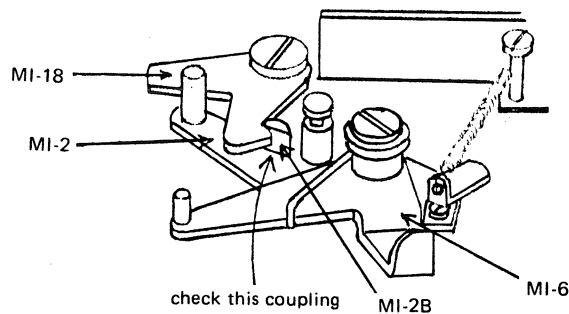


## Section 3 Malfunction Symptoms and Repair Guide

## Item 2 Winding (continued)

2. Winding lever fails to turn and shutter also does not operate.

- a.) Incorrect positioning of diaphragm lever (MI-6) and its related mechanism (AK-21)

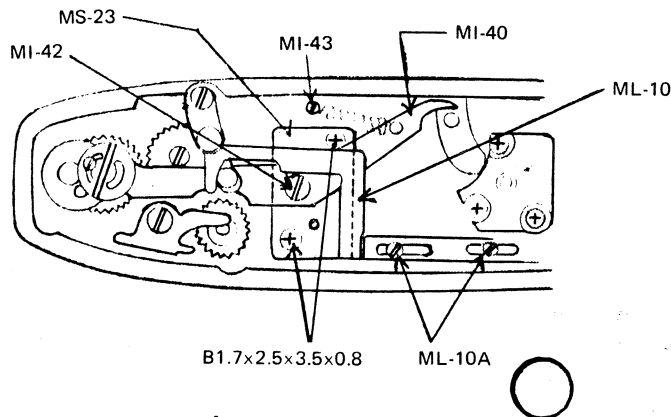


Check and adjust the position of diaphragm lever according to previous instructions described on Page 19 (6).

Check the coupling between release lever (MI-18) and stud (MI-2B) on lever (MI-2).

If necessary, replace defective parts.

- b.) 2nd curtain pinion (MS-17A) loose



Retighten or replace the pinion (MS-17A) as follows;

Remove all exterior parts described in Sec. 1 including

front cover (MB-11),  
right cover (SK-32),  
left cover (SK-40),  
bottom cover (MB-13),  
right front cover (AK-27),  
left front cover (MB-23),  
lens mount assembly (AK-26),  
mirror housing light baffle (MI-38),  
mirror housing assembly (SK-21).

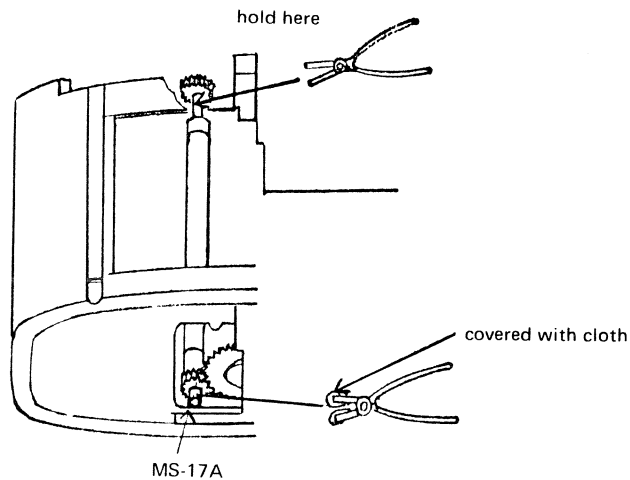
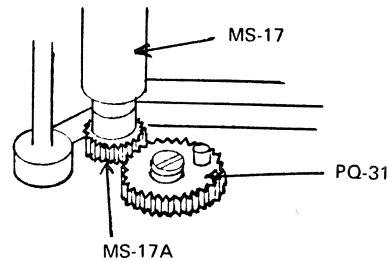
Then remove the shutter connecting lever (ML-10) from the bottom of camera body by taking out two holding screws (ML-10A).

The mirror setting lever (MI-40), positioned underneath the above lever (ML-10), also has to be removed by taking off the retaining screw (MI-42).

## Section 3 Malfunction Symptoms and Repair Guide

## Item 2 Winding (continued)

2. Winding lever fails to turn, and shutter also does not operate. (continued)



Take off return spring (MI-43) by removing the retaining pin (MI-43A), also remove shutter release gear (PQ-31) by removing two retaining screws (B 1.7 x 3.3 x 3.5 x 0.8).

At this stage the base plate for the shutter setting lower assembly (MS-23) can be taken off by removing screws (B 1.7 x 2.5 x 3.5 x 0.8).

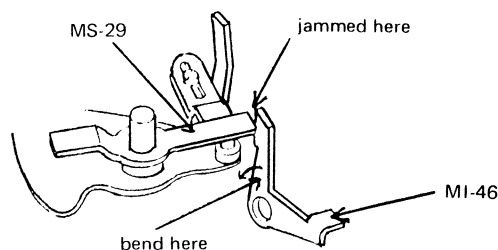
Retighten or replace the pinion (MS-17A) by screwing in or unscrewing the pinion at the lower end of 2nd curtain winding shaft (MS-17).

This should be done with pliers with the tips covered with cloth or other material. This is to prevent damage to the gears. The pinion should be inserted from the bottom of the camera body, at the same time holding the shaft (MS-17) with another pair of pliers.

For retightening, lock-tight (an adhesive bond) may be applied to prevent screws from working loose.

Adjust all gears and couplings and then re-assemble.

- c.) Curtain release lever (MS-29) and mirror release lever (MI-46) jammed.



Remove the winding assembly, AK19 (see Page 36) and shutter governor MS51 (see Pages 15 & 30) from camera body.

Free the levers and bend lever (MI-46) slightly toward the curtain release lever (MS-29) so as to ensure normal coupling between the two levers.

### Section 3 Malfunction Symptoms and Repair Guide

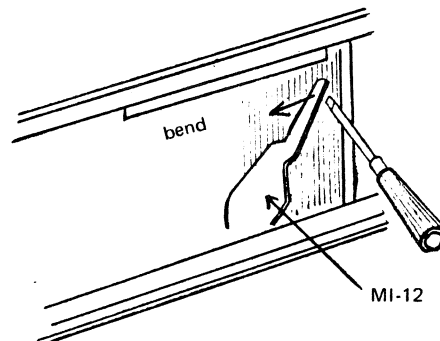
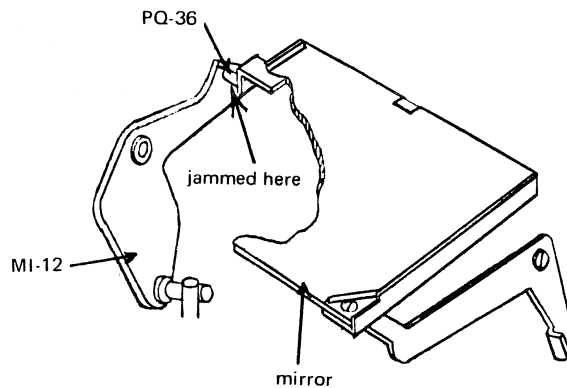
#### Item 2 Winding (continued)

2. Winding lever fails to turn, and shutter also does not operate. (continued)

d.) Mirror actuator lever (MI-12) and pin (PQ-36) jammed

Free the mirror actuator lever (MI-12) from the pin (PQ-36). Then bend the tip of mirror actuator lever (MI-12) slightly towards the mirror.

This is easily done by inserting a screwdriver through the picture format window (from rear of camera). At the same time the shutter curtains should be kept open by pressing the shutter release button which had previously been set at "B".

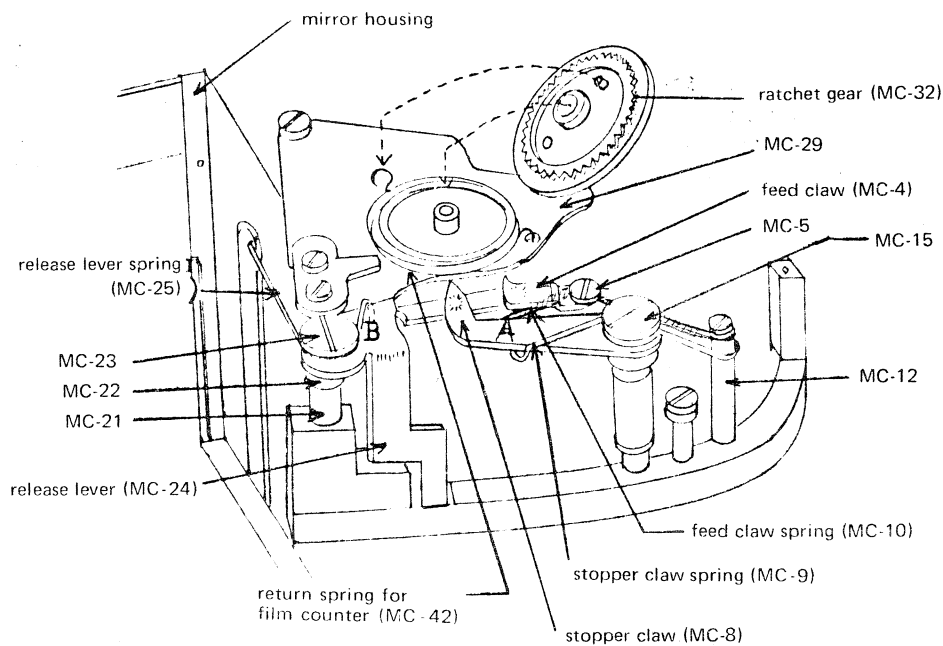


### Section 3 Malfunction Symptoms and Repair Guide

#### Item 3 Film counter

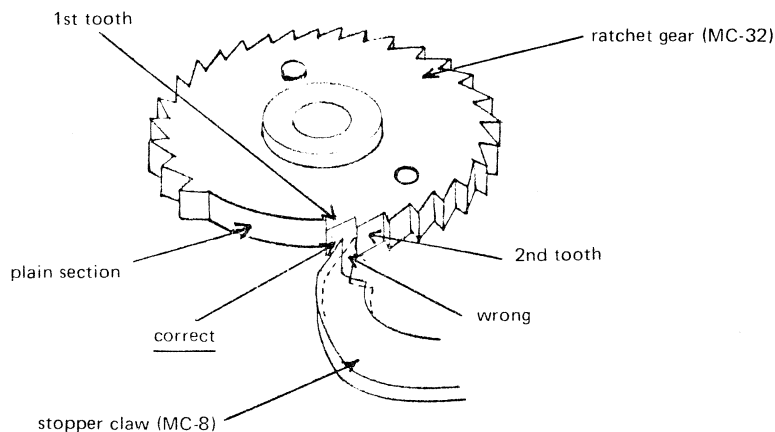
1. Film counter does not turn forward

Remove frontcover, MB-11 and right cover, SK-32 from camera body. (See Pages 1 and 2 for the dismantling instructions).



- a.) Incorrect positioning of stopper claw (MC-8)

Adjust the position of stopper claw (MC-8) by bending the tip of the claw so that it touches the rear side of the 1st or 2nd tooth of ratchet gear (MC-32). See illustration for correct position for the start of a roll of film.

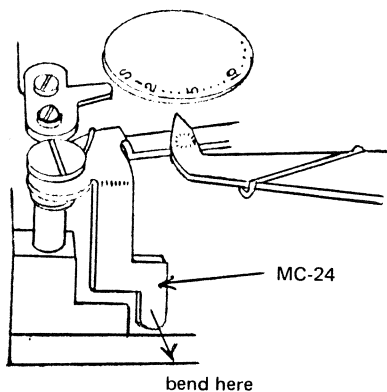


## Section 3 Malfunction Symptoms and Repair Guide

## Item 3 Film counter (continued)

1. Film counter does not turn forward (continued)

- b.) Release lever (MC-24) operation insufficient.



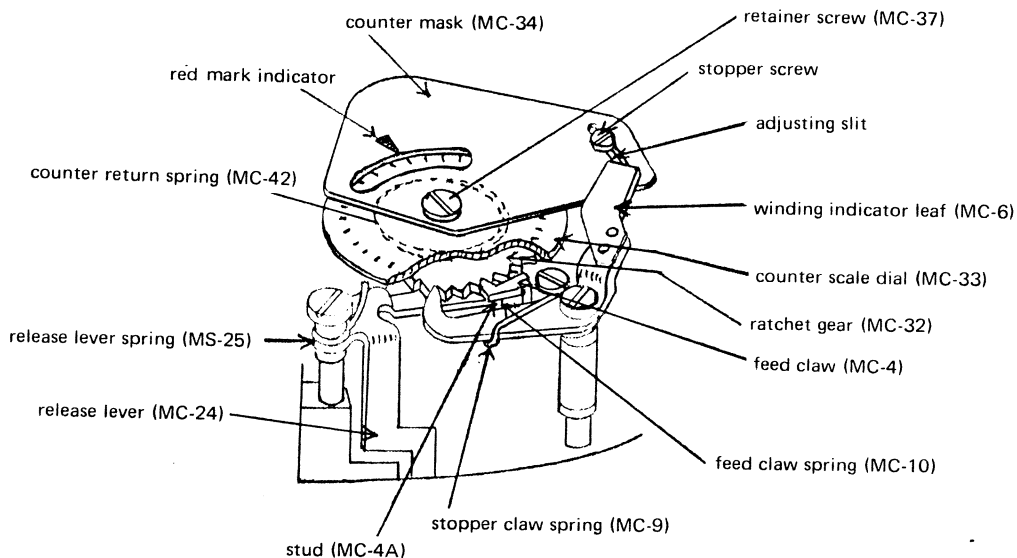
Bend the lower end of the release lever (MC-24) slightly to the outside, so as to make closer contact with the edge of the back cover. In other words, quicken the reaction of the lever.

- c.) Wrongly connected springs

Ensure a good connection of all springs as follows;

- 1) spring (MC-9) for stopper claw (MC-8);  
A - (MC-15) - (the lower groove of MC-12).
- 2) spring (MC-10) for feed claw (MC-4);  
stud (MC-4A) - (MC-5) - (the upper groove on MC-12).
- 3) spring (MC-25) for release lever (MC-24);  
B - (MC-23) - (side of mirror housing).

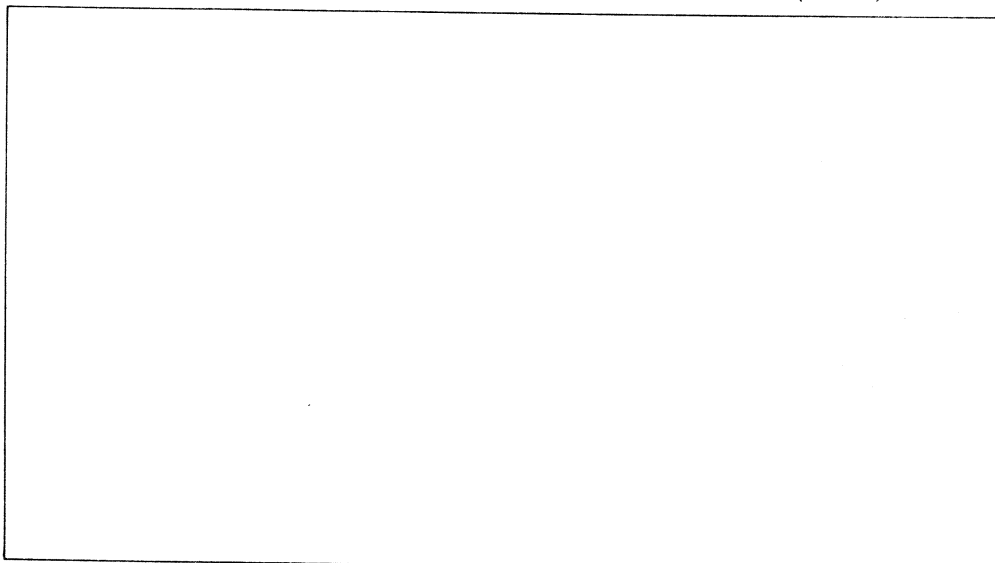
Refer to illustration on previous page.



## Section 3 Malfunction Symptoms and Repair Guide

## Item 3 Film counter (continued)

- |   |   |  |
|---|---|--|
| <p>1. Film counter does not turn forward (continued)</p>        | <p>d.) Ratchet out of order, gear broken (MC-32)</p>  | <p>Replace the ratchet gear (MC-32) and scale dial (MC-33) by unscrewing the top retaining screw (MC-37).</p> <p>Before removing the ratchet gear, disconnect spring (MC-12) carefully from stud (MC-32A) on the back of the ratchet gear (MC-32) and spring connecting hole in the base plate (MC-29).</p> <p>For re-assembly, re-hook the spring (MC-42). Then fit the ratchet gear after one turn of the wheel (MC-32) clockwise, together with scale dial, which is affixed to the wheel (MC-32).</p> <p>Then adjust the position of ratchet gear (MC-32) in the manner previously described in Item (a) on Page 41.</p> |
| <p>2. Film counter does not return to the "START" position.</p> | <p>a.) Broken or disconnected return spring (MC-42)</p> <p>b.) Malfunction of release lever (MC-24)</p> | <p>In case of a broken spring, replace the spring (MC-42).</p> <p>Fit the new spring (MC-42) in manner previously described in (d) above.</p> <p>Make adjustment by bending the horizontal lever-arm of the release lever (MC-24) slightly so that it is coupled with stud (MC-4A) under the feed claw (MC-4).</p>   |



### Section 3 Malfunction Symptoms and Repair Guide

#### Item 3 Film counter (continued)

2. Film counter does not return to the "START" position. (continued)

b.) Malfunction of release lever (MC-24) (continued)

Check for correct fitting of release lever spring (MC-25).

If necessary, replace defective parts.

c.) Incorrectly mounted springs

Refer to previous instruction on Page 42 (1c).

d.) Inaccurate reading caused by discrepancy between dial scale and red-mark indicator

Unscrew stopper screw (B 1.4 × 1.1 × 2 × 0.6) and loosen retaining screw (MC-37).

Adjust position of counter mask (MC-34) by moving it within the adjusting slit, so that the check mark (red-mark indicator) on the counter mask (MC-34) accurately corresponds to each of the figures on the scale dial (MC-33).

Then make a test by running the counter dial scale from S to 36 with the winding lever.

If no discrepancy is seen between the dial scale (MC-33) and the check mark (red-mark indicator), retighten screws, B 1.4 × 1.1 × 2 × 0.6 and MC-37.

If a discrepancy is still seen, particularly in the interval between releasing the shutter and advancing the film, check the position of the stopper claw (MC-8) and feed claw (MC-4) with the ratchet gear (MC-32).

The stopper claw (MC-8) should stop the ratchet gear (MC-32) in the coupled position on the 1st or 2nd tooth of the ratchet gear as described on Page 41 (1a).

### Section 3 Malfunction Symptoms and Repair Guide

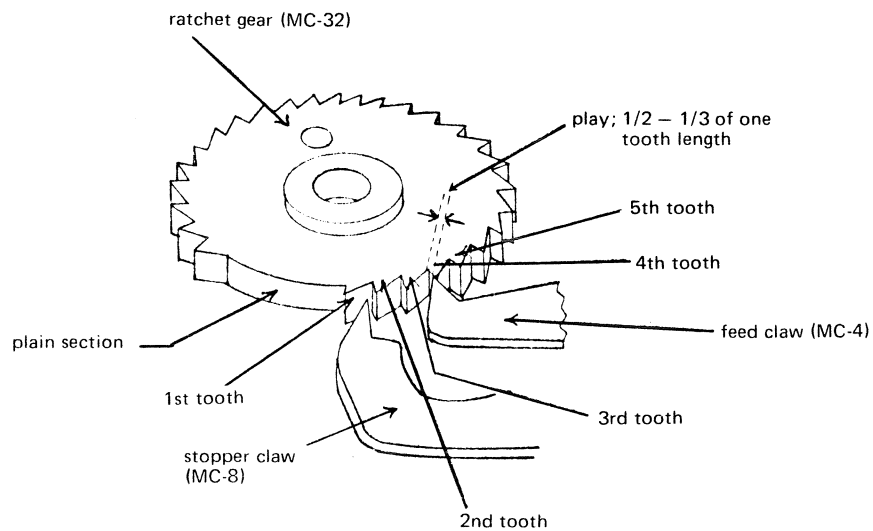
#### Item 3 Film counter (continued)

2. Film counter does not return to the "START" position. (continued)

d.) Inaccurate reading caused by discrepancy between shutter speed scale and red mark indicator (continued)

The feed claw (MC-4) should be positioned on the foreface of the 4th or 5th tooth (the third tooth from the tooth coupled to the stopper claw (MC-8)). There should be a space of  $1/2-1/3$  of face length of tooth. (see illustration)

Adjustment can be made by slightly bending the tip of the stopper claw (MC-8), in manner previously described on Page 41.





### Section 3 Malfunction Symptoms and Repair Guide

#### Item 4 Synchronization

##### 1. Defective circuit

###### a.) Wires disconnected

Rewire the circuit with new wire.

###### b.) Incorrect or high resistance contact due to deteriorated or rusty contacts (MF-8A or MF-12)

Remove front cover (MB-11), right cover (SK-32), left cover (SK-40), bottom cover (MB-13), right front cover (AK-27), left front cover (MB-23), lens mount assembly (AK-26), mirror light baffle (MI-38) and mirror housing (SK-21) as described in Sec. 1.

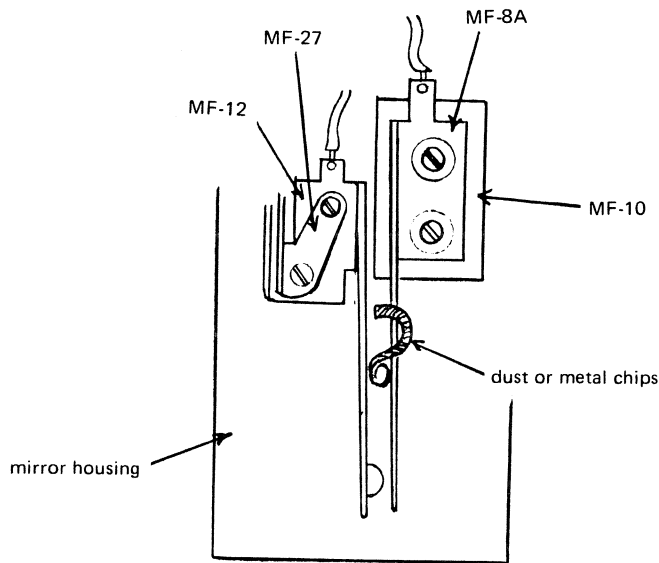
Replace the defective parts as follows;

1) For synch. contact (MF-12) unsolder the black wire and disconnect it from the synch. contact (MF-12). Then unscrew the two retaining screws (B 1.7 x 3 x 2.4 x 0.5) and take off insulator (MF-27). The synch. contact (MF-12) can now be replaced.

2) For FP-X contact (MF-8A), unsolder and disconnect the red wire from the FP-X contact (MF-8A). Then unscrew two retaining screws (B 1.7 x 3 x 2.4 x 0.5).

Now replace the FP-X contact.

After replacement of the defective parts, reassemble the contact in a reverse order to above description.



##### 2. No contact

###### a.) Dust or metal chips between contacts (MF-8A and MF-12)

Clean the contact and remove the dust or chips.

###### b.) Contact malfunctions due to

- (1) fastened too tightly
- (2) affected by moisture
- (3) became covered with oil
- (4) metal chips attached

Remove and clean the contact (MF-8A or MF-10) and area around it.

If necessary, replace the contact/s.

### Section 3 Malfunction Symptoms and Repair Guide

#### Item 4 Synchronization (continued)

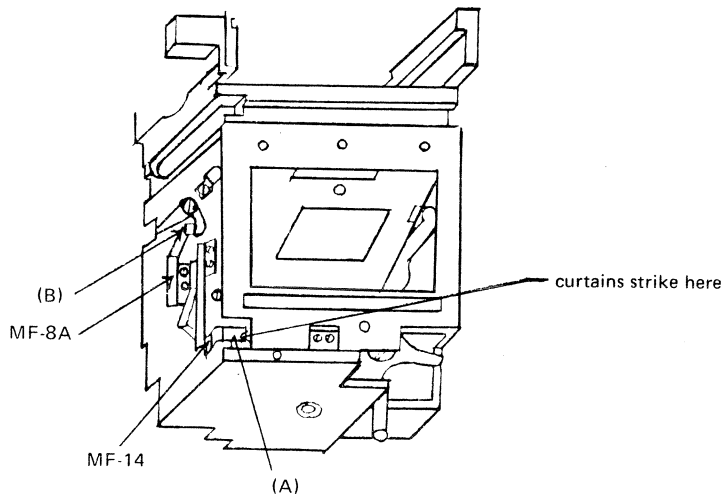
3. *Incorrect time-lag in X-contact*

a.) *Too fast  
1st curtain remains in  
picture format*

*Adjust reed (MF-14) so as to contact the 1st curtain at the correct moment of passing by means of bending the portion (A). (see illustration)*

b.) *Too slow  
2nd curtain remains in  
picture format*

*Same as above.*



4. *Incorrect time-lag in FP-contact*

a.) *Too short  
contact is made too  
early*

*Adjust contact point (B) so as to make contact at the correct moment. (see previous illustration)*

b.) *Too long  
contact is made too  
late*

*Same as above.*

*Remark: For the adjustment of synchronization, it is advisable to use the Insulation-Resistance Meter, model T-122.*

## Section 3 Malfunction Symptoms and Repair Guide

### Item 5 Focus

#### 1. Viewfinder

- a.) *Mirror incorrectly positioned at 45° angle*

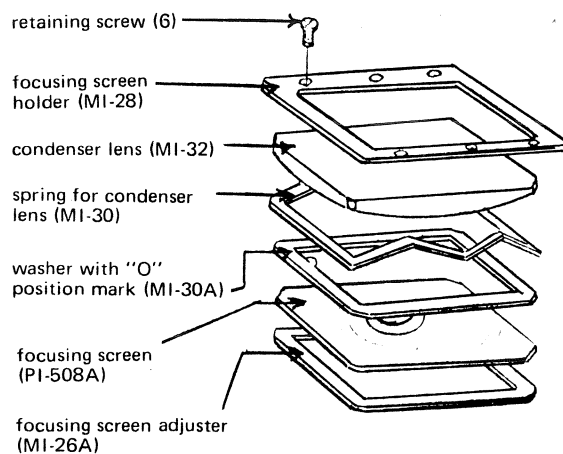
Make adjustment in manner previously described on Page 25.

The adjustment can be easily carried out when the 45° Mirror Angle Measuring Equipment, model T-85 is used.

- b.) *Inaccuracy in focusing screen*

After removing the pentaprism viewfinder of the camera, unscrew the six retaining screws (B1.4 x 3 x 2.4) from focusing screen holder (MI-28). Then lift off the following;

- 1) Focusing screen holder (MI-28)
- 2) Condenser lens (MI-32)
- 3) Condenser lens spring (MI-30)
- 4) Washer with "O" position mark for the follow needle (MI-30A)
- 5) Focusing screen (PI-508A)



Focusing screen adjuster (MI-26A) can now be seen below the focusing screen.

Correct the position of the adjuster (MI-26A).

If necessary, replace the adjuster (MI-26A) with one having an appropriate thickness. There are eight kinds of adjusters in thicknesses from 0.1mm up to 1mm.

### Section 3 Malfunction Symptoms and Repair Guide

#### Item 5 Focus (continued)

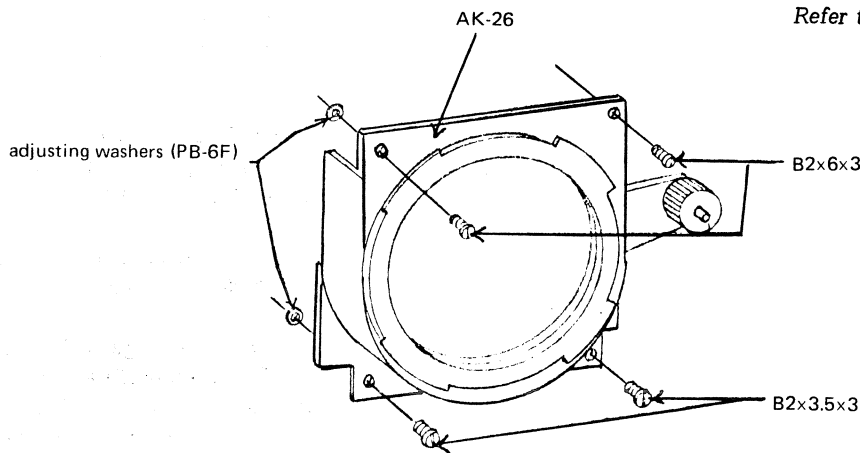
#### 2. Film plane

##### a.) Improper mounting of lens

Change position of the lens mount assembly by replacing adjustment washers (PB-6F) under the retaining screws with one of the appropriate thickness.

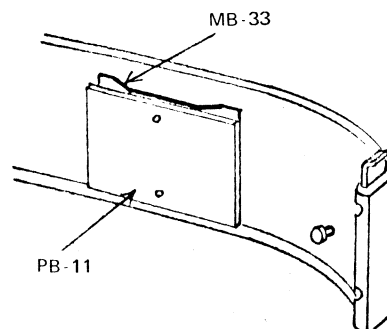
There are five kinds of washers, in thicknesses of 0.03mm, 0.05mm, 0.08mm, 0.15mm and 0.2mm.

Refer to Page 7 for details of dismantling.



##### b.) Pressure plate bent

Replace the pressure plate (PB-11) and spring (MB-33) by removing two rivets (MB-39).



## Section 3 Malfunction Symptoms and Repair Guide

## Item 5 Focus (continued)

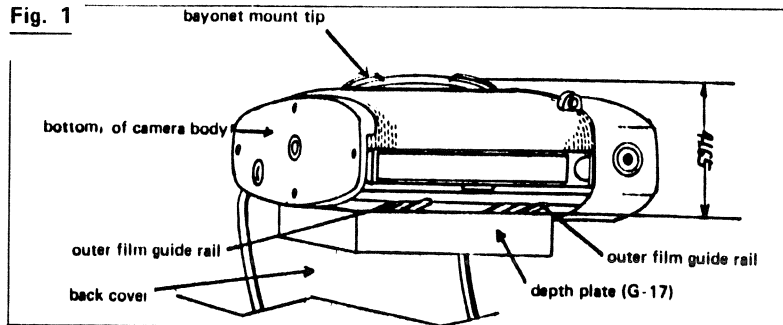


Fig. 1 shows a camera body placed upon depth plate (G-17) after removal of the back cover.

As indicated in Fig. 1, the distance from the bayonet mount top of lens mount assembly (AK-26) to the outer film guide rail of the body should be adjusted to 41.65mm.

Fig. 2 shows depth gauge (G-18) which is tubular shaped and is exactly 41.65mm in height.

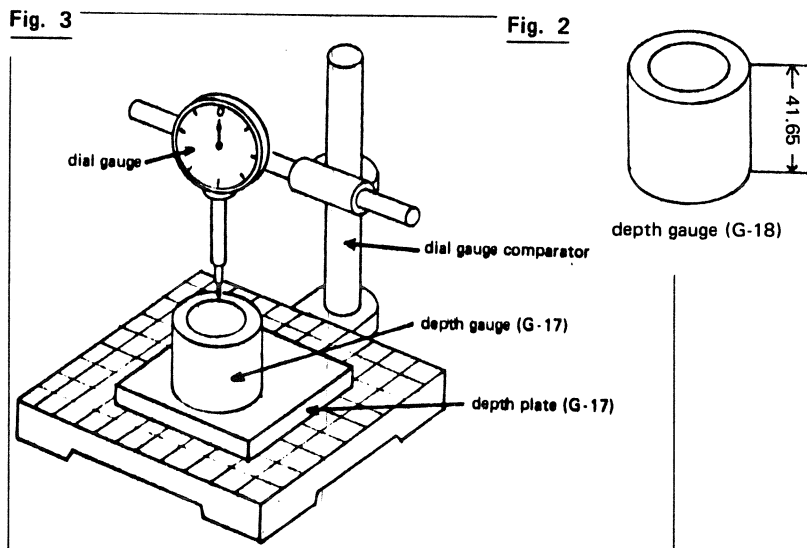
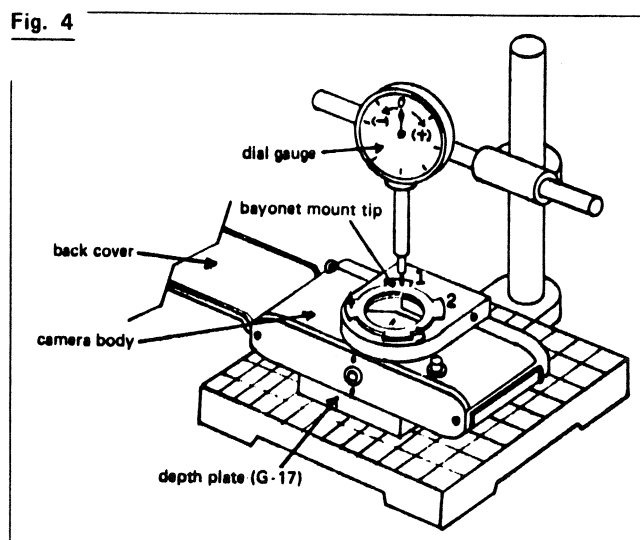


Fig. 3 shows the dial gauge "O" position when the depth gauge (G-18) is placed upon the depth plate (G-17).

Now replace the depth gauge (G-18) with the camera body to be measured.

Measurement of the flange back is carried out at the four corners of the lens mount assembly. The exact depth of the four corners is indicated by a + (Plus) or - (minus) value on the dial gauge.

If the readings differ at any corner, adjustment should be made by inserting the adjustment washers (PB-6F) with appropriate thickness in manner previously described.



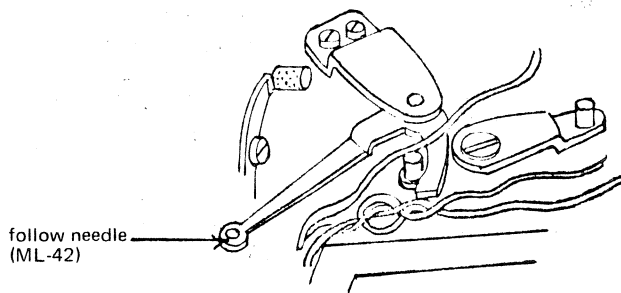
The tolerance of depth at each corner should be within  $\pm 0.02\text{mm}$ .

## Section 3 Malfunction Symptoms and Repair Guide

## Item 6 Exposure meter

## 1. Follow needle failure

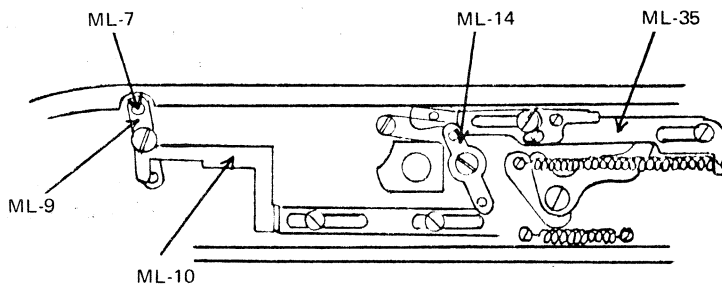
## a.) Caught in wiring



Dismantle front cover (MB-11) and left cover (SK-40) from body in manner previously described on Pages 1 & 3.

Then free the needle (ML-42) from the wiring.

## b.) Insufficient coupling of levers in bottom mechanism



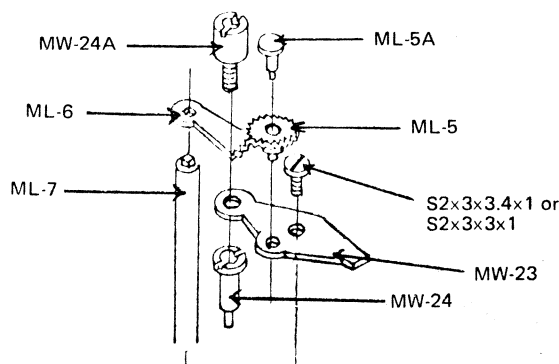
Remove bottom cover (MB-13) from camera body in manner previously described on Page 4.

Check the operation of the bottom mechanism as follows:

- 1) Carefully check the movement of lower link lever (ML-9) while progressively turning the shutter speed dial from low to high. If the movement of the lower link lever is not sufficient, especially at the high shutter speeds (1/500-1/1000 sec.), remove right cover (SK-32) as previously described on Page 2.

Now check the gearing of segment gear (ML-6 on AK-14) which is located under the ASA speed dial in the upper shutter assembly.

See that the segment gear is properly coupled with idle gear (ML-5A on AK-17). If not, loosen retaining screw (S 2 x 3 x 3.4 x 1 or S 2 x 3 x 3 x 1) of spring stopper plate (MW-23) and adjust the coupling by changing the position of the spring stopper plate (MW-23) to which the idle gear (ML-5A) is connected.



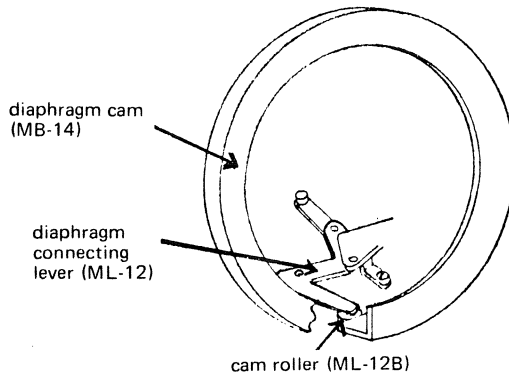
- 2) Inspect all lever screws in the bottom mechanism. If any loosening is found, retighten.

Section 3 Malfunction Symptoms and Repair Guide

Item 6 Exposure meter (continued)

1. Follow needle failure (continued)

c.) Cam roller disconnected from diaphragm cam

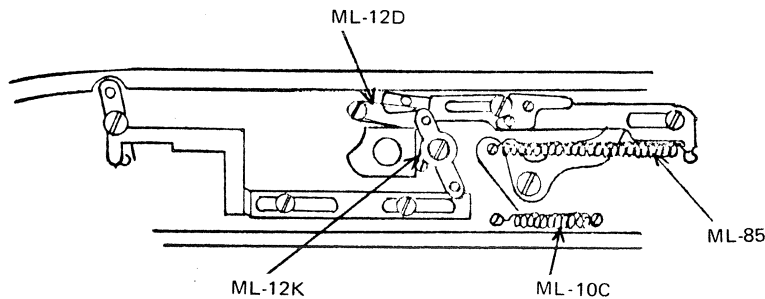


In the event of the mechanism in the bottom section jamming even when turning the diaphragm setting lever, a possible cause is that the cam roller has become uncoupled from the diaphragm cam.

In this case, remove front cover (MB-11), bottom cover (MB-13) and lens mount assembly (AK-26) as previously described on Pages 1, 4 & 7.

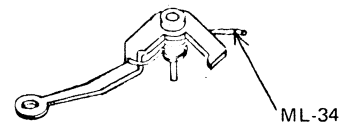
Now adjust the diaphragm connecting lever (ML-12) by bending the arm of the lever slightly upward so that it is touching cam (MB-14).

d.) Disconnected springs in bottom mechanism and on the follow needle

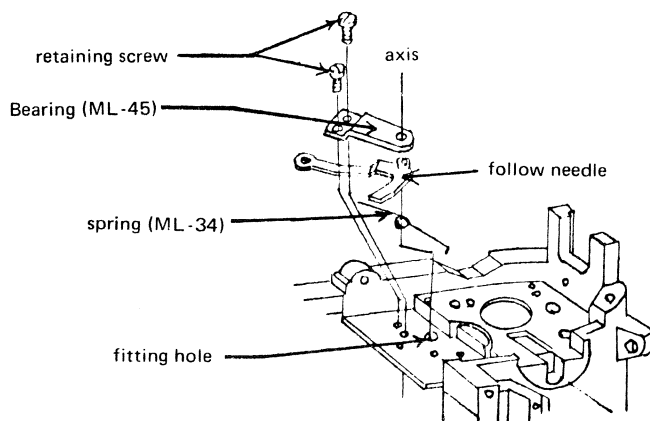


Rehook springs onto the appropriate parts as illustrated.

- 1) ML-12K: spring for variable lever of lens speed selector.
- 2) ML-10C: return spring for diaphragm actuator cam
- 3) ML-85: spring for follow needle cam base plate
- 4) ML-12D: diaphragm connecting lever.
- 5) ML-34: follow needle spring



e.) Axis of follow needle out of alignment



Loosen the two retaining screws of bearing (ML-45). Adjust the centre of all fitting holes between the bearing and camera body so that they are aligned to give a smooth movement of the follow needle. Then re-fasten the two retaining screws.

## Section 3 Malfunction Symptoms and Repair Guide

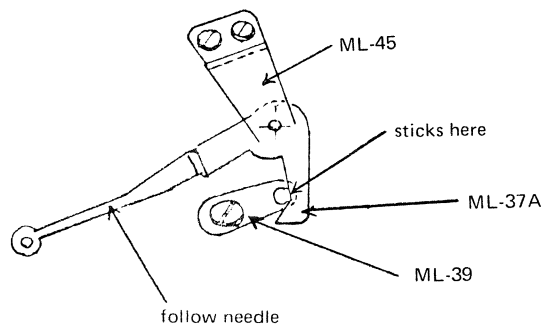
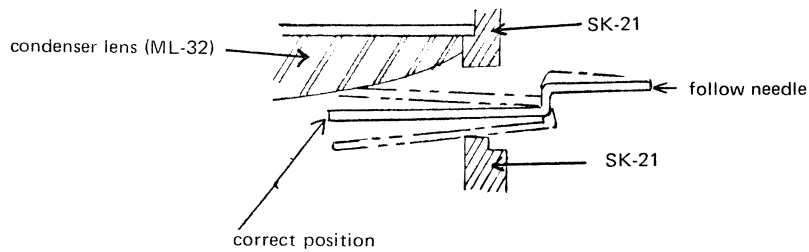
## Item 6 Exposure meter (continued)

1. Follow needle failure (continued)

f.) Follow needle catching or sticking

Bend the follow needle slightly and adjust in manner previously described on Page 20 (1b).

Alternatively, slightly bend the other end of the follow needle upward and adjust the coupling between hook (ML-37A) on the upper lever of follow needle setting cam (ML-39), so as to ensure that it does directly touch lever (ML-39).





### Section 3 Malfunction Symptoms and Repair Guide

#### Item 6 Exposure meter (continued)

#### 2. Meter needle failure

a.) Disconnected wires

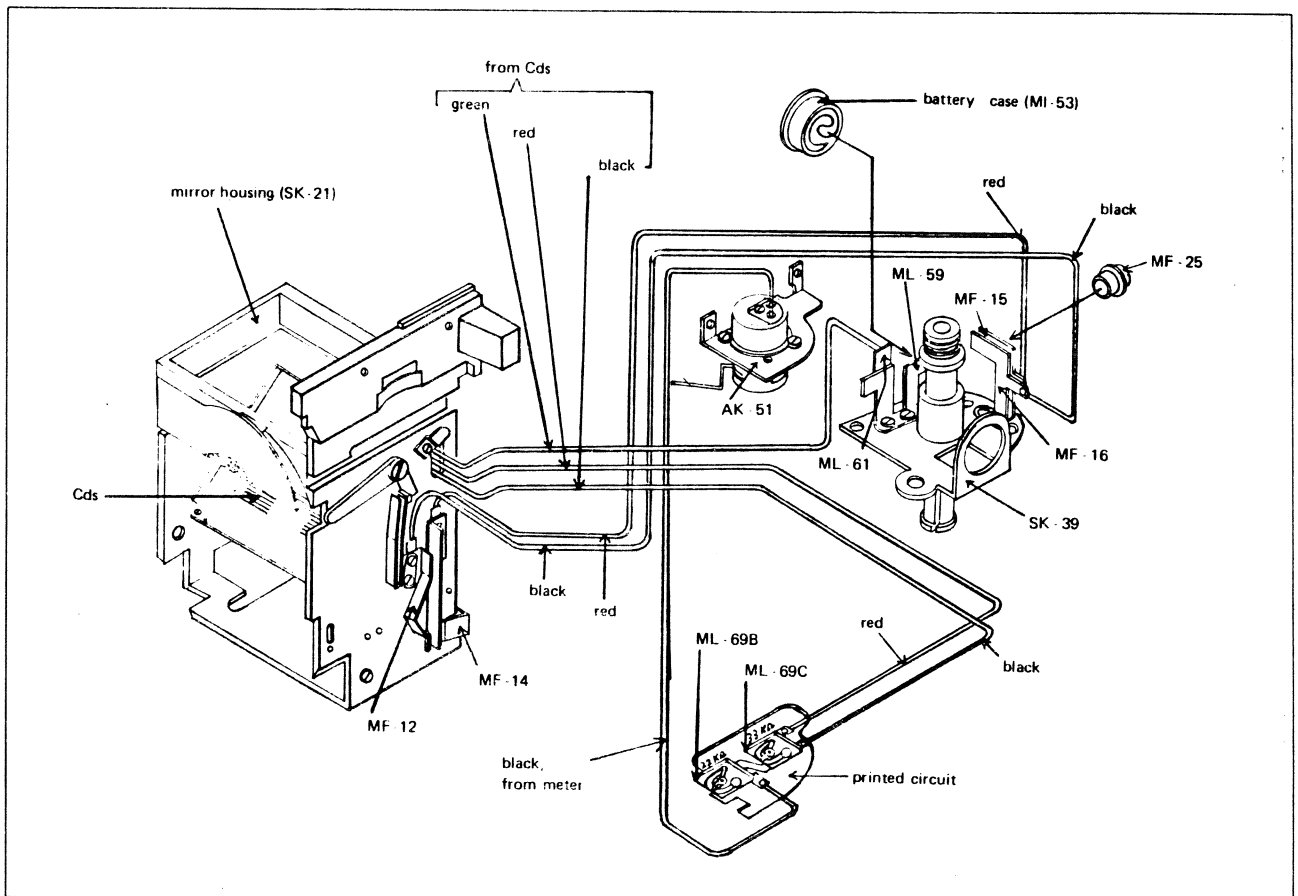
Replace wires according to diagram.

b.) Short circuit in wiring.

Replace wires according to diagram.

c.) Dust or metal chips in meter movement

Remove foreign matter with tweezers.

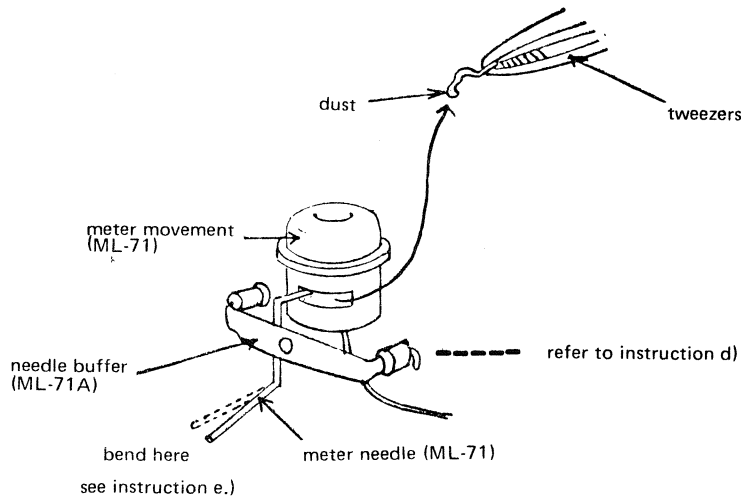


## Section 3 Malfunction Symptoms and Repair Guide

## Item 6 Exposure meter (continued)

## 2. Meter needle failure

d.) Defect in meter needle buffer (ML-71A).



Adjust the buffer by bending the end of the buffer's "O" position, so that the play between the buffer's end and the meter needle at "O" position is 0.5mm-1.0mm. If necessary, replace defective parts.

e.) Meter needle bent

Bend the tip of the meter needle and adjust the movement. If meter needle still fails, replace meter movement (ML-71).

f.) Incorrect fitting position of meter movement (ML-71)

Adjust the position as previously described on Page 20 (1b).

## 3. Incorrect reading of Light Value (LV)

a.) At low intensity

Refer to previous instruction on Page 21 (c-1).

b.) At medium and high intensity (LV 11, LV 15 and 17).

Refer to previous instruction on Page 21 (c-2) & (c-3).

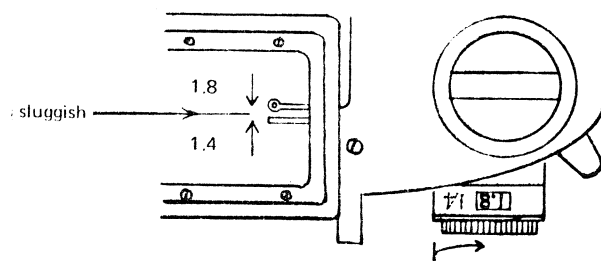
## 4. Incorrect lens speed dial (LS dial) operation

a.) Follow needle sluggish when the lens speed dialed from 1.4 to 1.8 (or 1.9)

Correct the "O" position of follow needle as previously described on Page 23.

Before performing the following repairs to the LS dial, remove front cover (MB-11) and left cover (SK-40).

Then remove leather cover of LS dial (ML-98) and dismantle parts in the order as illustrated on Page 56.



Section 3 Malfunction Symptoms and Repair Guide

Item 6 Exposure meter (continued)

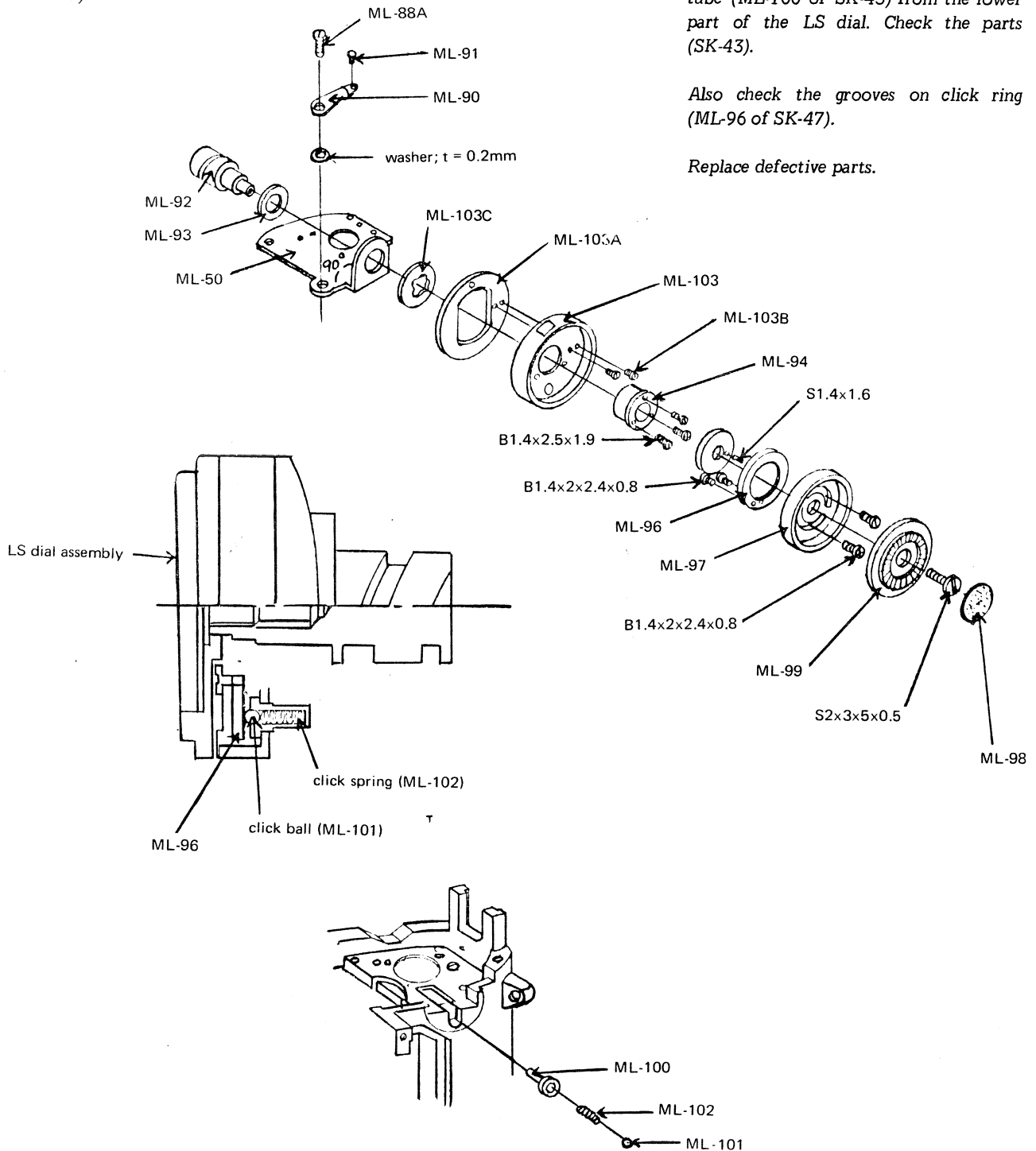
4. Incorrect lens speed dial (LS dial) operation (continued)

b.) Indefinite click stops

After removal of ring (ML-103C), see the illustration, unscrew click ball container tube (ML-100 of SK-43) from the lower part of the LS dial. Check the parts (SK-43).

Also check the grooves on click ring (ML-96 of SK-47).

Replace defective parts.



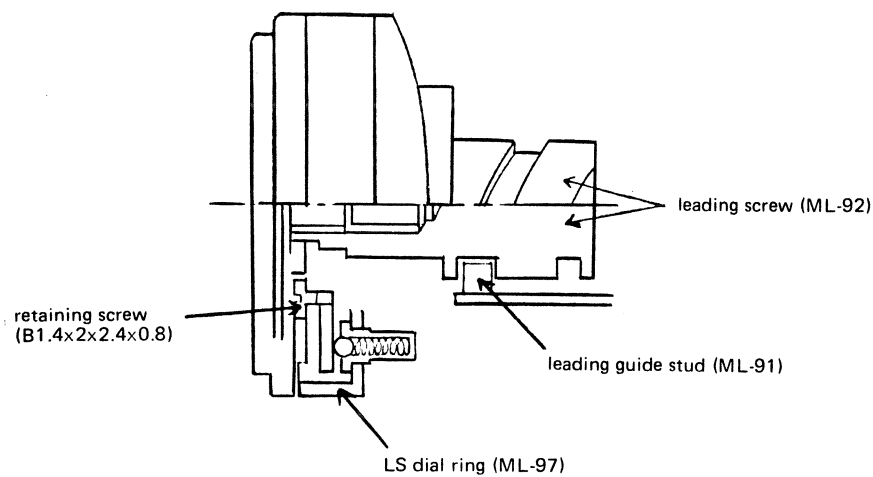
## Section 3 Malfunction Symptoms and Repair Guide

## Item 6 Exposure meter (continued)

4. *Incorrect lens speed dial operation. (continued)*

c.) *Loose fitting of lens speed dial ring (ML-97)*

*Make sure the two retaining screws (B 1.4 x 2 x 2.4 x 0.8) are tight.*



d.) *Friction between leading screw (ML-92) and the stud (ML-91)*

*Adjust the coupling between leading screw (ML-92) and the stud (ML-91). Check the angle which is formed by the raised portion of base plate (ML-50) so as to be an accurate 90°. The stud (ML-91) should be coupled with the screw (ML-92) in the right angle, see illustration on page 55. If necessary, replace defective parts.*

e.) *Incorrect setting of rivet (ML-103B) in lens speed dial ring cover (ML-103 of SK-45).*

*Adjust the position of the rivet so that it does not touch the lens speed dial ring (ML-97). See illustration on page 55.*

f.) *Incorrect fitting position of coupling levers in bottom mechanism*

*Check and adjust the levers for correct coupling as previously described on Page 50 (1b).*

**SECTION 4**  
**SPECIAL TEST EQUIPMENT**



**Section 4 Special Test Equipment****TABLE OF CONTENTS**

---

	<i>(Use)</i>	<i>(Equipment)</i>
<i>Item 1</i>	<i>Shutter</i>	<i>1. Shutter Tester. Model PA-23D</i>
<i>Item 2</i>	<i>Shutter Curtain and Autodiaphragm Mechanism</i>	<i>1. Tension Gauge (dial), 0g - 300g 2. Tension Gauge, 0g - 300g</i>
<i>Item 3</i>	<i>Meter Needle</i>	<i>Scale Adjusting Plate. Model T-86</i>
<i>Item 4</i>	<i>Reflecting Mirror:</i>	<i>45° Mirror Angle Measuring Equipment, Model T-85</i>

\* \* \* \* \*

*Note: Other instruments which are available but not listed here are:*

*Light Value Meter. Model T-121.*

*Insulation Resistance Meter. Model T-122.*

*Auto Collimator. Model T-130.*

## SHUTTER TESTER OPERATION

## MODEL PA23-D

Section 4. Item 1.

---

### Summary

*This is an instrument for measuring time by deviation in meter readings. It is designed to measure the working time, the delay time and the time relation of X contact with a focal plane shutter. The instrument is fully transistorized.*

### Main performance

1. *Measurement of exposure time*  
1 sec. to 1/2000 sec., measurement of exposure irregularities according to JIS B7126.
2. *Curtain speed*  
0 to 15 ms (exclusively for vertical opaque curtain)  
0 to 30 ms (exclusively for transversal opaque curtain)
3. *Delay time*  
0 to 30 ms
4. *Reset*  
Resetting is fully automatic and resets immediately the measurement is started. The previously measured value remains indicated until the next measurement.
5. *Indication*  
Indication is performed by 1.5 class 2131 type measuring instrument.  
Measurement of deviations in exposure time are from -100 to +100% and +3 to -1EV.



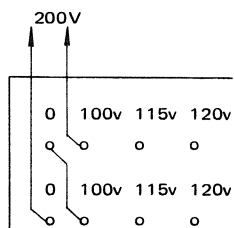
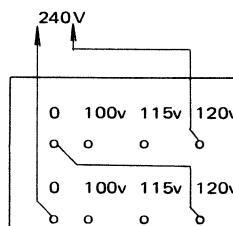
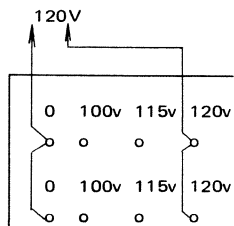
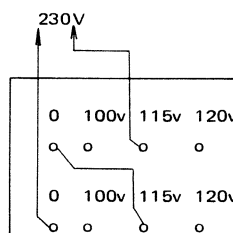
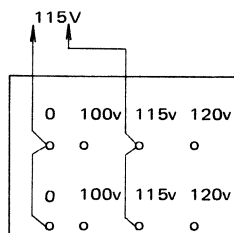
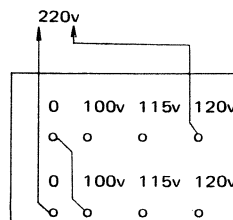
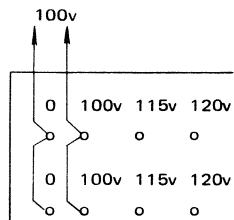


## SHUTTER TESTER OPERATION

## MODEL PA23-D

## Details of measurement

	<i>Item for measurement</i>	<i>Meter to be used</i>	<i>Indication</i>	<i>Measurement Indicated (Milliseconds or %)</i>
1	Synchro contact	A	Time from synchro contact until the first curtain passes (Start) S.	m.s.
		B	Time from synchro contact until the first curtain passes (Central) C.	m.s.
		C	Exposure time deviation at the (Central) position	%
2	X contact	A	Time from the first curtain passing (End) until the X contact	m.s.
		B	Time from X contact until the second curtain passes (Start).	m.s.
		C	Time of full opening of shutter	m.s.
3	Curtain speed	A	Curtain speed of first curtain	m.s.
		B	Exposure time deviation at the (Central) position	%
		C	Curtain speed of second curtain	m.s.
4	Exposure time	A	Exposure time deviation at the (Start) position	%
		B	Exposure time deviation at the (Central) position	%
		C	Exposure time deviation at the (End) position	%
5	Curtain speed of first curtain	A	Curtain speed of the former half of first curtain	m.s.
		B	Curtain speed of the latter half of first curtain	m.s.
		C	Total curtain speed of the first curtain	m.s.
6	Curtain speed of second curtain	A	Curtain speed of the former half of second curtain	m.s.
		B	Curtain speed of the latter half of second curtain	m.s.
		C	Total curtain speed of the second curtain	m.s.



## Section 4 Special Testing Equipment

### Item 2 Tension Gauge

Tension Gauge with indicator dial (Fig. 1) or with indicator scale (Fig. 2). The measuring scale is calibrated up to 300g and it is used for measuring the tension strength of 1st and 2nd curtain of the focal plane shutter.

Please refer to Pages 13 and 19 regarding the operation of these gauges.

These tension gauges are also used for measuring the tension strength of the main spring (MI-4) which is coupled with the auto-diaphragm mechanism (AK-21) in the bottom of the mirror housing.

Refer to Pages 27 & 38 for performing the previous operation.

These two tension gauges may be purchased at any time.

Fig. 1

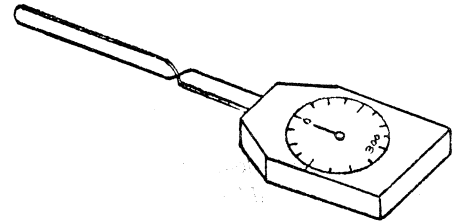
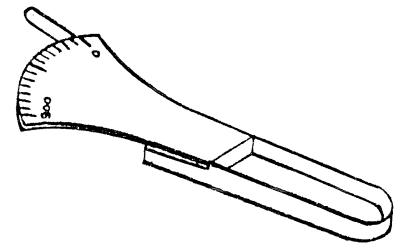


Fig. 2



## Section 4 Special Testing Equipment

### Item 3 Meter Needle Adjusting Scale, model T-86

A transparent plastic plate, the size of the focusing screen (PI 508A) with two scales (A and B) engraved on the surface is used for adjusting the deflection angle of the meter needle.

After removing the pentaprism viewfinder of the camera, unscrew the six retaining screws (B 1.4 x 3 x 2.4) from focusing screen holder (MI-28). Then lift off the following;

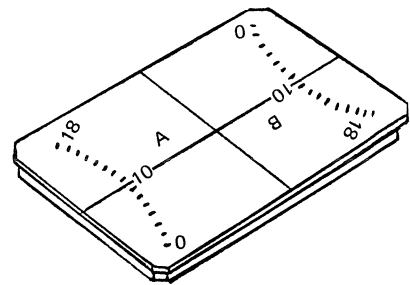
- 1.) Focusing screen holder (MI-28)
- 2.) Condenser lens (MI-32)
- 3.) Condenser lens spring (MI-30)
- 4.) Washer with "O" position mark for the follow needle (MI-30A)

Now the focusing screen (PI-508A) can be replaced with the transparent plastic scale plate.

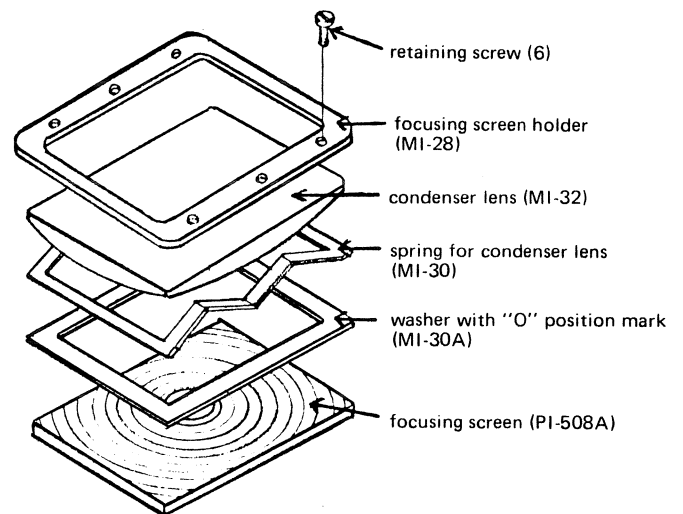
Scale "A" on this plate is used for the old type follow needle shaped like a broken circle, and scale "B" is used for the new type which is shaped like a complete ring.

To use, insert the scale plate in place of the focusing screen so that one of the scales is positioned right above the needles.

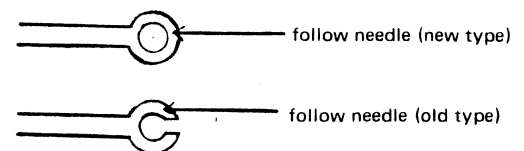
**Fig. 1**



**Fig. 2**



**Fig. 3**



## Section 4 Special Testing Equipment

Section 4: (continued)

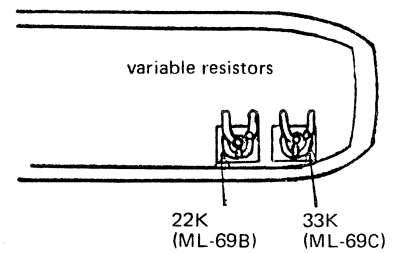
---

(Item 3 Meter Needle Adjusting Scale, Model T-86)

This transparent plastic plate is most useful for giving the correct zero position of the meter needle.

Adjustment of the deflection angle of the meter needle is made by altering the resistance of one or both the variable resistor(s), 33K (ML-69C) and/or 22K (ML-69B) which is found in the bottom mechanism. It should be carried out in the manner previously described on Pages 21 & 22.

Fig. 4



Section 4 Special Testing Equipment

Item 4 45° Mirror Angle Measuring Equipment, model T-85

45° Mirror Angle Measuring Equipment, T-85, is similar to a lens mount cover, but has a scale glass in the nose-tip. This is used for measuring the correct 45° angle position of the reflecting mirror.

After dismantling the camera lens, the T-85 is screwed into the lens mount so that the nose tip points outwards.

The correct position of the reflecting mirror to 45° is indicated as an overlapped image, caused by the round scale-mark of this measuring equipment and the microprism ring of the viewfinder.

The round scale-mark should appear within the micro-image ring of the viewfinder when viewed through the finder eyepiece (see Fig. 3-a) for correct position of the mirror.

If the round scale-mark is misplaced in the image of the microprism (see Fig. 3-b), correct the position by adjusting the mirror angle with lever (MI-116) and/or 45° angle adjusting pin (MI-23 or 23A). (see Fig. 4)

For adjustment as above, please refer to the previous instructions on Pages 25 & 48.

Fig. 1

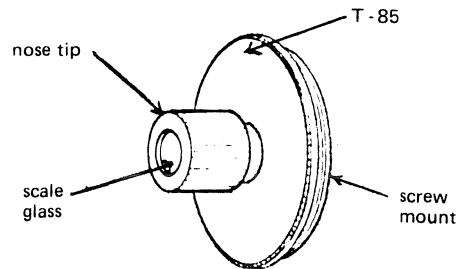


Fig. 2

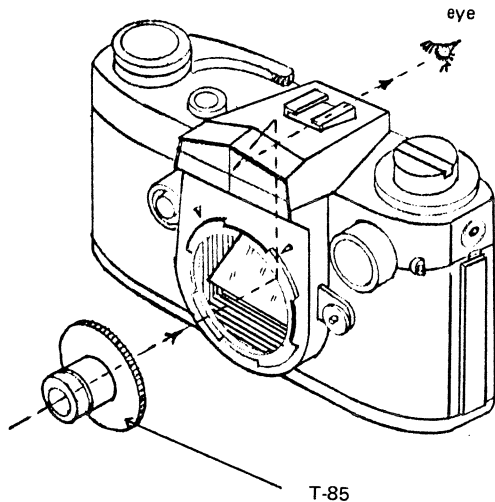


Fig. 4

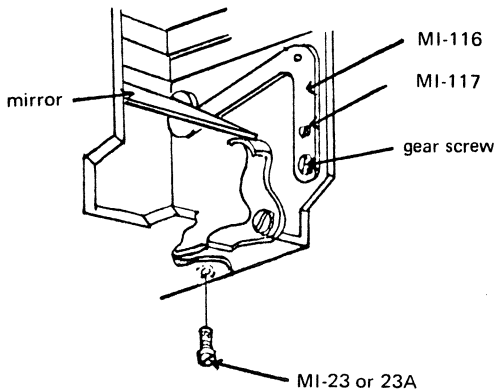
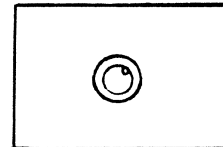
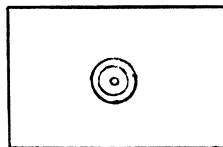


Fig. 3-a

Fig. 3-b



a

b


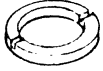
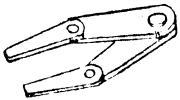
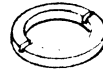
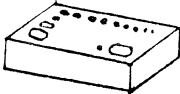

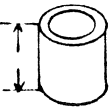
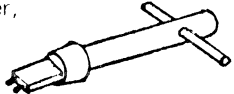

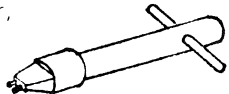

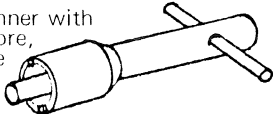

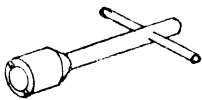





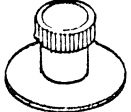




**SECTION 5  
SPECIAL REPAIR TOOLS**



## Section 5 Special Repair Tools

Tool		TO BE USED ON		Remarks
Tool No.	Name and Sketch	Parts No.	Sketch	
G-2	Tweezers 	(lens retainer ring)		can be used for all lenses
G-15	Tweezers 			
G-16	Rivetting plate 	.....	.....	can be used for all rivets
G-17	Depth plate 	.....	.....	can be used universally
G-18	Depth gauge 	.....	.....	
G-22	Box spanner, bit only 	MT-16		can also be used for AM model
G-23	Box spanner, bit only 	MI-36		
G-24	Box spanner with center core, complete 	MW-28		
G-25	Box spanner, complete 	MW-54 (old type)		
G-25-1	Box spanner, bit only 	MW-54 (new type)		
G-35	Spanner wrench, bit only 	MS-16		can also be used for AM model
G-65D	Solder container 	.....	.....	can be used universally

Note: Drawings are not to scale.



**SECTION 6  
PARTS LIST**



## Section 6 Appendix

## Parts List

---

AK 55	battery cap
AK -46	pentaprism assembly
AK -46B	prism cover assembly
MP -4 -3	prism cover
MP -6B (2)	seat metal
S 1.7 x 5 x 2.4 (2)	retaining screw for prism cover, top
S 1.7 x 3 x 2.4 (2)	retaining screw for prism cover, flank
B 1.7 x 2.4 x 3.5 x 0.8 (2)	retaining screw for MP -2
MP -2	prism supporter
MP -2B	prism pad
MP -4D	light shield ribbon
PP -8	pentaprism
MP 5	eyepiece ring
B 1.7 x 2.4 x 3.5 (2)	retaining screw for MP -1A
MP -1A	holder for eyepiece lens
PP -805	eyepiece lens
MP -1	prism case
MP -4E (2)	cushion rubber for prism
MP -3	prism front cover
B 1.7 x 2 x 2.4 (2)	retaining screw for MP -3
S 1.4 x 5.2 x 2 x 0.8 (2)	retaining screw for MS -68 -6 or MS -69
MS -68 -6 or MS -69	shutter speed dial
MS -67A	retaining spring for MS -67
MS -67	ASA speed adjusting ring
AK -35	ASA speed dial assembly
ML -3A or ML -3B	adjusting gear
MS -66 -3	gear for MS -67
AK -52	dial base assembly
S 1.7 x 2.5 x 2.5 x 1 (3)	retaining screw for MW 40
MW -40	film winding lever

## Section 6 Appendix

## Parts List (continued)

---

AK - 42	rewind crank assembly
MW - 55	washer for MW - 56
MW - 54	retaining ring for AK - 41 - 1
AK - 41 - 1	synch. contact selector assembly
MF - 24 G	spring washer
MF - 17E	click ball for synch. selector dial and Cds meter switch
AK - 41 - 2	synch. contact indicator assembly
AK - 41 - 3	Cds meter switch lever assembly
MF - 24F	washer for AK - 41 - 3
MB - 25 - 2	leather for left front cover
MB - 24 - 1	leather for right front cover
ML - 31	spacer plate for ML - 105
ML - 105	decoration plate
B 1.4 x 2.3 x 2.4 (2)	upper retaining screw for MB - 11
MB - 11	front cover
MB - 11B (2)	lower retaining screw for MB - 11
MB - 11C - 2	bottom retaining screw for MB - 11
MT - 17	self - timer starting lever
MT - 16	self - timer lever stopper
S 1.7 x 3 x 2.4 (3)	retaining screw for AK - 11
AK - 11	back cover assembly
PB - 14C (2)	back cover lock
MW - 38	rewind button
MB - 13 - 4	bottom cover
B 1.7 x 2 x 2.4 (4)	retaining screw for MB - 13 - 4



## Section 6 Appendix

## Parts List (continued)

B 1.4 x 2.3 x 2.4 (6)	retaining screw for MI - 28
MI - 28	focusing screen holder
MI - 32	condenser lens
MI - 30	spring washer for MI - 32
MI - 30A	washer with "O" (zero ) position mark
PI - 508A or PI - 508B	focusing screen
MI - 26A	focusing screen adjuster
PI - 409	focusing screen frame
B 1.4 x 2.3 x 2.4 (2)	retaining screw for SK - 32 and SK - 40, top
B 1.7 x 2 x 2.4 x 0.2 (2)	retaining screw for SK - 32 and SK - 40, back
B 1.4 x 2 x 2.4 x 0.2 (2)	retaining screw for SK - 32 and SK - 40, flank
SK - 32	right cover assembly
SK - 40	left cover assembly
MS - 34C	shutter release spring
S 1.7 x 2.5 x 2.5 (3)	retaining screw for AK - 6
AK - 6	base plate assembly for AK - 25
AK - 25	self - timer assembly
1.7 x 2 x 2.4	retaining screw for AK - 25
B 1.7 x 2.4 x 3.5 x 0.8 (2)	retaining screw for AK - 25
B 1.4 x 2 x 1.9 (4)	retaining screw for AK - 27 and MB - 23 - 1
AK - 27	right front cover assembly
MB - 23 - 1	left front cover
PB - 6F (4)	adjusting washer for AK - 26 (five kinds of thicknesses are available for this part; 0.03mm, 0.05mm, 0.08mm, 0.15 mm and 0.2 mm)
B 2 x 6 x 3 (2)	upper retaining screw for AK - 26
B 2 x 3.5 x 3 (2)	lower retaining screw for AK - 26
AK - 26	lens mount assembly

## Section 6 Appendix

## Parts List (continued)

---

1.4x1.5x1.9 (2)	retaining screw for PI-811
PI-811	mirror holder
PI-815	reflector mirror
MK-22-7	Cds cell
MK-22-6	mirror frame
AK-21-5	reflector mirror assembly
PI-14A(L=17)	collar for mirror shaft, left
PI-14A (L=22)	collar for mirror shaft, right
SK-21	mirror housing assembly
B 1.4x2x1.9 (2)	retaining screw for MI-125
MI-125	mirror shaft bearing
1.4x1.6	holder screw for mirror shaft
MI-16B-1	retaining screw for MI-16
MI-16	mirror stopper lever
AK-21-7	mirror stopper lever assembly
MI-16C	spring for AK-21-7
MI-16A-1	washer for MI-16 and MI-46-3
MI-46-3	mirror release lever
MI-46A-2	washer for MI-46-3
MI-16E	hanger for MI-16C
MI-15-3	retaining screw for AK-21-4
AK-21-4	connecting lever assembly
MI-14-1	washer for AK-21-4
PQ-9	washer for SK-21-3
SK-21-3	mirror actuator lever assembly
PQ-14A	stopper for SK-21-3
MT-6	retaining screw for MT-6A
MT-6A	eccentric washer for mirror action control with self-timer
MT-4	retaining screw for AK-21-6
MT-5	spring for AK-21-6
AK-21-6	self-timer control assembly
MI-3-2	washer for AK-21-6

## Section 6 Appendix

## Parts List (continued)

S 1.4x3x2.4 (2)	retaining screw for MB 121-5
MB-121-5	fitting plate for ML-105 and MB-11
B 1.4x2x1.9 (2)	retaining screw for MI-37-2
MI-37-2	front light baffle
PI-1M	mirror cushion
B 1.4x2x1.9 (4)	retaining screw for SK-21-8, back
SK-21-8 (KI-44 and KI-44A)	back light baffle
B 1.4x1.5x2.4x0.8	retaining screw for SK-21-8, flank
MI-36 or MI-36A	prism lock button
MI-36B	washer for MI-36 or 36A, 0.3mm thick
MI-36C	washer for MI-36 or 36A, 0.4mm thick
MI-36D	washer for MI-36 or 36A, 0.5mm thick
MI-36E	washer for MI-36 or 36A, 0.2mm thick
MI-35	stopper rod for locking prism
MI-34	prism locking spring
MI-33	holding plate for MI-34
B 1.4x2x2.4x0.8 (2)	retaining screw for MI-33
MI-1A-3	holder spring for pentaprism assembly
MI-116	horizontal mirror position adjusting lever
B 1.7x3x2.4	bearing for MI-116
MI-117	eccentric pin for mirror horizontal adjustment
B 1.7x2.5x3.5x0.8	retaining screw for MI-116
PQ-42	retainer for PQ-40-2
B 1.7x4x2.5	stopper screw for PQ-42
MI-23 or MI-23A	45° mirror position adjusting pin
PQ-40-2	45° mirror position adjusting lever
MI-25	spring for PQ-40-2
B 1.7x4x2.5	retaining screw for PQ-40-2
MI-21	retaining screw for MI-18
MI-19	spring for MI-18
MI-20	washer for MI-18
MI-18	mirror release lever
MI-18A	stopper for MI-18

## Section 6 Appendix

## Parts List (continued)

---

MI-11	stopper for mirror housing bottom mechanism
MI-10-1	retaining screw for SK-21-1 and SK-21-2
MI-7	spring for SK-21-2
SK-21-2	diaphragm lever assembly
MI-5	stopper for MI-4-1
MI-4-1	spring for SK-21-1
SK-21-1	rotating lever assembly
MI-3-2	washer for mirror housing bottom mechanism
B 1.4x1.5x2.4x0.8 (2)	retaining screw for SK-21-9
SK-21-9 (MI-38 and MI-39)	bottom light baffle
PQ-33	stopper for SK-21-2
2x3x2.5x1	retaining screw for PQ-33
B 1.4x2.8x2.4x0.8 (2)	retaining screw for AK-51
AK-51	Cds meter movement assembly
B 1.4x1.1x2x0.6	retaining screw for AK-53
AK-53	swing stopper for meter needle
1.4x1.5x2x0.8	retaining screw for MI-112
ML-112	wire holder
B 1.4x1.5x2x0.6	retaining screw for PW-529 or MI-123-1
PW-529 or MI-123-1	wire holder
MF-3	retaining screw for MF-1-2
MF-2	washer for MF-1-2
MF-1-2	synch. contact lever
B 1.7x3x2.4x0.5 (4)	retaining screw for MF-8 and MF-12
PF-509A (4)	insulation washer for MF-8 and MF-12
MF-8 or MF-8A-1	FP-X synch. contact
MF-10-2	insulator for MF-8 or MF-8A-1
MF-27	outer insulator for MF-12
MF-12	synch. contact
MF-12A	inner insulator for MF-12
B 1.4x2.5x2.4x0.8 (2)	retaining screw for ML-107
ML-107	wire repeater (or relay)

## Section 6 Appendix

## Parts List (continued)

---

B 1.4x1.5x2.4x0.8 (2) MF-14-3	retaining screw for MF-14-3 X-synch. contact
S 1.7x4x3.5x1.5 (2) AK-19	retaining screw for AK-19 film winding assembly
B 1.7x2x3.5x0.8 (2) MW-25E	retaining screw for MW-25E film wind stopper
S 1.7x3x3.5x0.8 MW-24A	retaining screw for AK-19, and for MW-24A bearing shaft
S 2x3x3x1  AK-17 (or MW-23) AK-16 (or MW-23A and MW-20A) AK-14 MW-16A-1 (3) AK-12 MW-2A-2 MW-4B MW-4C-1	retaining screw for AK-17, AK-16 and AK-14 holder assembly for AK-16 spring case assembly winding ratchet gear assembly retaining screw for AK-12 base plate assembly for AK-12 winding spool gear shaft collar for MW-2A-2 spring for MW-2A-2
MS-25	connecting tube
MC-12 MC-11 MS-9C	hanger shaft for MC-11 spring for AK-15 stopper for MW-25E
MW-9-2 AK-15 MW-8 MW-7AB	stopper shaft for AK-15, MW-8 and MW-7AB stopper assembly washer for AK-15 intermediate gear for AK-15
MW-11 MW-10	gear shaft for MW-10 intermediate gear
AK-14-1 ML-8A	ASA gear assembly tube for AK-14-1

## Section 6 Appendix

## Parts List (continued)

---

2 x 2.5 x 5 x 0.8	retaining screw for MS - 10/12AB and MS - 6 - 7
MS - 10/12AB	2nd curtain gear assembly
MS - 6 - 7	1st curtain gear assembly
MS - 25B	fitting tube for S 1.7 x 3 x 3.5 x 0.8
MC - 15	retaining screw for AK - 30 and AK - 29
MC - 9	spring for AK - 30
AK - 30	counter stopper claw assembly
MC - 14	washer for AK - 30
MC - 10	spring for MC - 4
AK - 29	film counter lever assembly
MC - 13	connecting tube for AK - 29
MC - 25	spring for MC - 24
MC - 23 - 1	retaining screw for MC - 24
MC - 22 - 1	washer for MC - 24
MC - 24	film counter release lever
MC - 21	connection tube for MC - 24
S 1.7 x 1.8 x 3 x 0.8	retaining screw for AK - 28
S 1.7 x 3.5 x 3 x 0.8	----- same as the above -----
MC - 26	connecting tube for AK - 28
AK - 28	counter base plate assembly
MS - 51B	retaining screw for MS - 51
1.7 x 3 x 3.5 x 0.8	----- same as the above -----
MS - 25B	fitting tube for the above screw
MS - 51	shutter governor assembly
MS - 32A	guide screw for MS - 32
MS - 32	relay lever
1.7 x 3 x 2.4	retaining screw for AK - 8
MS - 31	"B" speed plate
MS - 30B	collar for MS - 31
MS - 44A	adjusting washer for AK - 9 and AK - 10
MS - 29B	upper adjusting washer for AK - 8
AK - 8	shutter release lever assembly
MS - 29A	lower adjusting washer for AK - 8
AK - 3	upper shutter assembly

## Section 6 Appendix

## Parts List (continued)

---

B 1.7 x 3 x 2.4 x 0.8 (4)	retaining screw for SK - 39
SK - 39	base plate assembly for film rewind shaft and LS (lens speed) dial
SK - 45	LS dial ring cover assembly
SK - 48	leading screw assembly for LS dial
1.4 x 3.5 x 2 (3)	retaining screw for SK - 48
SK - 47	LS dial ring assembly
B 1.4 x 2 x 2.4 x 0.8 (2)	retaining screw for SK - 47
ML - 99 - 1	LS dial
S 2 x 3 x 5 x 0.5	retaining screw for ML - 99 - 1
ML - 98	leather cover for LS dial
ML - 88A	retaining screw for ML - 90 and ML - 50
ML - 90	lead lever
ML - 91	retaining screw for ML - 90
washer, 0,2 mm thick	washer for ML - 90
SK - 43	click assembly for LS dial
1.4 x 1.7 x 2.4 x 0.8 (2)	retaining screw for ML - 45
ML - 45	bearing for AK - 36
ML - 34	spring for AK - 36
MS - 52	upper base plate for shutter curtain springs
1.7 x 2 x 3.5 x 0.8 (2)	retaining screw for AK - 20
AK - 20	shutter release gear assembly
1.7 x 7 x 3 x 1 (2)	retaining screw for MB - 19 (2)
MB - 19 (2)	strap catch
PI - 1K (3)	retaining screw for mirror housing
AK - 33	link cam assembly for follow needle
ML - 41A	spring for AK - 37
ML - 38	washer for AK - 37
AK - 37	lower link assembly

## Section 6 Appendix

## Parts List (continued)

---

MW - 37	sprocket
MW - 37A	key screw for retaining sprocket
MW - 36B	adjusting washer for MW - 37
MW - 35	bearing for AK - 1
PW - 9A	washer for MW - 37
AK - 1	sprocket shaft assembly
AK - 5	film spool assembly
MW - 4B	washer for MW - 12
MW - 12	lower spool gear
MW - 15	spring for MW - 14
MW - 12B	mirror setting cam
MW - 12A	retaining screw for MW - 12
MW - 14A	retaining screw for MW - 14
MW - 14	anti reverse claw
MW - 13	adjusting nut for MW - 14
MW - 33 - 2 (for AK - 2)	mirror setting intermediate gear
MW - 34	retaining screw for MW - 33 - 2
B 1.7 x 3 x 2.5 x 1 (4)	retaining screw for AK - 4
AK - 4	lower base plate for winding mechanism
B 1.7 x 2.5 x 3.5 x 0.8 (2)	retaining screw for MS - 23
MS - 23	base plate for lower shutter assembly
MW - 31	retainer and gear shaft for MW - 29
MW - 30	holder plate for rewind button
MW - 32	spring for MW - 30
MW - 29	intermediate gear
1.4 x 2.4 x 3 x 0.8	retaining screw for AK - 18
AK - 18	lower link assembly
ML - 8	collar for AK - 18
PS - 27J	washer for AK - 18
ML - 16A	spring hanger for ML - 12D
ML - 12D	spring for SK - 22 (ML - 12F)



## Section 6 Appendix

## Parts List (continued)

---

ML - 12L	stopper screw for ML - 12K
ML - 12K	spring for SK - 22 (ML - 12F)
ML - 12G	collar for SK - 22 (ML - 12F)
ML - 12H (2)	screw for ML - 12F in SK - 22
PB - 6F (2)	washer for ML - 12F in SK - 22
SK - 22	diaphragm connecting lever assembly
ML - 88A	retaining screw for ML - 87
ML - 87	lead lever cam
1.7x4.5x3x0.8 (3)	retaining screw for MB - 4
MB - 4	tripod adapter
ML - 10A (2)	retaining screw for ML - 10
ML - 10	shutter connection lever
ML - 110	spring hanger
ML - 10B (2)	washer for ML - 10
MI - 42	retaining screw for AK - 24
AK - 24	mirror setting lever assembly
MI - 43A	spring hanger for MI - 43
MI - 43	spring for AK - 24
MI - 41	bearing for AK - 24
ML - 33A	retaining screw for SK - 50
ML - 33B	----- same as the above -----
PB - 6F (2)	washer for SK - 50
SK - 50	base plate assembly for diaphragm cam
ML - 44A	washer for SK - 50
1.7x2.5x5x1	retaining screw for AK - 54
ML - 13	washer for AK - 54
AK - 54	LS (lens speed) lever assembly
B 1.7x2.5x2.5	retaining screw for ML - 83A
ML - 83A	base plate for AK - 54
ML - 10C	spring for SK - 50

## Section 6 Appendix

## Parts List (continued)

---

1.7x2.2x2.4x0.8 PW-529	retaining screw for PW-529 wire holder
1.7x3x2.4 (2) ML-111 (2)	retaining screw for ML-111 wire holder
MS-44A (2) MS-21B (2) PS-16 (2) AK-9	washer for AK-9 and AK-10 ----- same as the above ----- roller for 2nd curtain drum 2nd curtain drum assembly
AK-10 PS-15 (2) MS-53 MS-29C (2) MS-54B (2) MS-54D (2), or PS-23D for later model	1st curtain drum assembly collar for shutter drums lower base plate for shutter springs washer for MS-54B curtain spring tension adjuster stopper screw for MS-54B

---

NOTE. The above part numbers are subject to change without notice,  
if structural changes are made.