

**PENTAX®**

# Service Manual

ENGLISH

**PENTAX 67II**

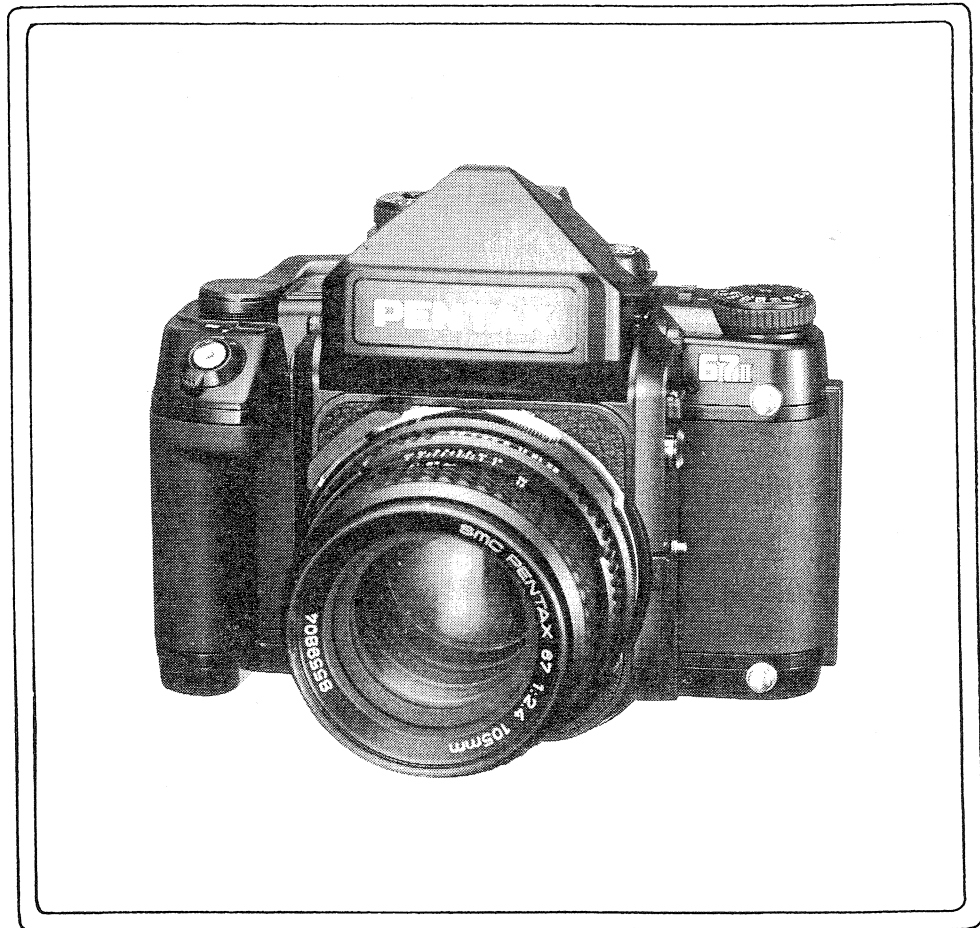

**Product No.27340**

\*\*\*\*\* CONTENTS \*\*\*\*\*

Disassembly and Assembly Outline-----	2
Disassembly and Assembly Procedure	
1. Body I (disassembly procedure)-----	4
2. Body I (assembly procedure)-----	11
3. Body II-----	27
4. Unit parts of body-----	29
5. Disassembly of mirror box-----	31
6. Assembly of mirror box-----	38
7. Assembly of O-D1 (mirror base plate assy.)-----	53
8. Assembly of curtain-----	56
9. Attachment of L1 (main mirror)-----	61
10. Bending of T100 (main P.C. board), etc.-----	62
List of 27340 jigs, tools and testing devices-----	64
Programmed soft Flow chart-----	65

\*\*\*\* List of main items for adjustment and checking \*\*\*\*

2.5 Position of winding stopper (adjust).....	13
2.6 Position of charge gear (adjust).....	13
2.7 Amount of mirror charge (adjust).....	14
2.16 Mechanical back, mirror 45 degrees, mount lock pin (adjust).....	17
2.20 Static current, operation (check).....	19
2.21 Curtain speed, shutter speed adjustment (adjust).....	19
2.22 Shutter bounce (adjust) .....	20
2.28 Focus adjustment (adjust).....	21
2.33 Adjustment using program software (adjust).....	23
2.36 Inspection guidelines (check).....	25
6.26 Shutter curtain alignment (adjust).....	47
6.27 Bounce block installing position (adjust).....	48
6.29 ES Magnet (adjust).....	49
6.30 Function of Mirror box (check).....	49
6.33 Shutter curtain installing condition (check).....	52
7.5 Function of Mirror base plate (check).....	55

## \*Disassembly and Assembly Outline

### \*Structure of this manual

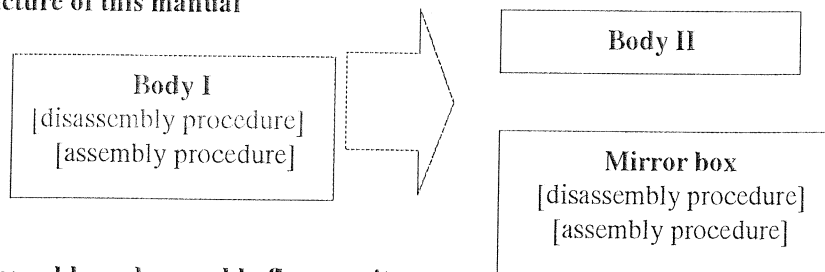

### \*Disassembly and assembly flow per item

(check): item to be checked

(adjust): item to be adjusted

#### 1. Body I [disassembly procedure]

- 1.1 Grip rubber, body leather
- 1.2 Bottom cover (A121)
- 1.3 Rear cover (A321)
- 1.4 Focus screen frame (M1)
- 1.5 Front cover, left (A131)
- 1.6 Left side cover (0-A101)
- 1.7 Top cover, left (0-A351)
- 1.8 Right side cover (0-A111)
- 1.9 Winding lever (C51)
- 1.10 Top cover, right (0-A301)
- 1.11 Tripod plate assy. (0-B32)
- 1.12 Under cover, right, left (A401, A451)
- 1.13 Grip (0-A501) and related parts
- 1.14 Lead wires (T100)
- 1.15 PCV holder (A87)
- 1.16 Back cover switch pedestal (A80)
- 1.17 Rear cover spacer (A322)
- 1.18 LCD install plate (E101)
- 1.19 M. E restrict plate (E88)
- 1.20 Winding lever click switch (C89, C90)
- 1.21 Duality prevention coupler lever (0-C25)
- 1.22 Shutter charge main gear (assy.) (0-C1)
- 1.23 Winding shaft plate (0-C34)
- 1.24 Winding lock interval lever B (0-C26)
- 1.25 Mirror box and body II

#### 2. Body I [assembly procedure]

- 2.1 Mirror box and body II
- 2.2 Winding lock interval lever B (0-C26)
- 2.3 Winding shaft plate (0-C34)
- 2.4 Shutter charge main gear (assy.) (0-C1)
- 2.5 Winding stopper position (adjust)
- 2.6 Charge gear position (adjust)
- 2.7 Mirror charge quantity (adjust)
- 2.8 Duality prevention coupler lever (0-C25)
- 2.9 Winding lever click switch (C89, C90)
- 2.10 M. E restrict plate (E88)
- 2.11 LCD install plate (E101)
- 2.12 Rear cover spacer (A322)

2.13 Rear cover switch pedestal (A80)

2.14 Lead wire (T100)

2.15 Grip (0-A501) and related parts

2.16 Mech. back, mirror 45 degrees,  
mount lock pin (adjust)

2.17 Under cover, right, left (A401, A451)

2.18 Top cover, right (0-A301)

2.19 Winding lever (C51)

2.20 Static current, operation checking (check)

2.21 Curtain speed,  
shutter speed adjustment (adjust)

2.22 Shutter bounce adjustment (adjust)

2.23 PCV holder (A87)

2.24 Right side cover (0-A111)

2.25 Left side cover (0-A101)

2.26 Front cover, left (A131)

2.27 Top cover, left (0-A351)

2.28 Focus adjustment (adjust)

2.29 Focus screen frame (M1)

2.30 Rear cover (A321)

2.31 Tripod plate assy. (0-B32)

2.32 Bottom cover (A121)

2.33 Adjustment using program software (adjust)

2.34 Grip rubber, body leather

2.35 Application of black mat paint

2.36 Inspection guidelines (check)

#### 3. Body II

3.1 Application of L114

3.2 Film retainer roller parts

3.3 Back cover key and Back cover (assy.)

3.4 Winding Mg, spool axis and related parts

3.5 Film pulse related parts

3.6 Soldering and treatment of lead wire

#### 4. Unit parts of body

4.1 Top cover, right (A301) and related parts

4.2 Top cover, left (A351) and related parts

4.3 Grip (assy.) (0-A501) and related parts

## **5. Mirror box [disassembly procedure]**

- 5.1 Focus screen SW contact (B21)
- 5.2 AM Switch (B41)
- 5.3 Duality prevention lever (0-E91)
- 5.4 Removal of Main P. C. Board (T100)
- 5.5 Shutter curtain operation lever
- 5.6 X Switch (I230)
- 5.7 Release of curtain tension
- 5.8 Damper mech. (A0-E1)
- 5.9 Curtain charge gear (0-E80)
- 5.10 Curtain checker lever (E82)
- 5.11 1<sup>st</sup> and 2<sup>nd</sup> curtain
- 5.12 Magnet plate (D59)
- 5.13 Mirror base plate (0-D1)
- 5.14 Bayonet seat (B2)
- 5.15 Focus screen adjusting plate (M3)
- 5.16 Viewfinder contact board (0-T301)
- 5.17 Viewfinder positioning pin (M11)
- 5.18 Diaphragm coupler ring (0-K102)
- 5.19 Anti-reflection sheet (D155)
- 5.20 Mirror sheet (0-D125)
- 5.21 Duality prevention coupler lever (0-C25)
- 5.22 Other parts

## **6. Mirror box [assembly procedure]**

- 6.1 Light sensor (0-J201)
- 6.2 Lock release pin (0-B14)
- 6.3 Light seal cushion (B50)
- 6.4 Damper plate (D132, D133)
- 6.5 Adhere Main mirror (L1)
- 6.6 Mirror sheet (0-D125)
- 6.7 Mirror arm pedestal spring (D124)
- 6.8 Light seal curtain (B47)
- 6.9 Resistor (K101)
- 6.10 Diaphragm coupler ring (0-K102)
- 6.11 Viewfinder positioning pin (M11)
- 6.12 Viewfinder contact board (0-T301)

- 6.13 Focus screen adjusting plate (M3)
- 6.14 Light seal string (B5)
- 6.15 Bayonet seat (B2)
- 6.16 Mirror base plate (0-D1)
- 6.17 Light seal tape D130)
- 6.18 Magnet plate (D59)
- 6.19 FPC install plate (D37)
- 6.20 Wind-end SW contact (D72, D73)
- 6.21 Mirror stopper support spring (D67)
- 6.22 Shutter curtain operation lever
- 6.23 1<sup>st</sup> and 2<sup>nd</sup> curtain
- 6.24 Curtain tension
- 6.25 Curtain checker lever (E82)
- 6.26 Curtain alignment (adjust)
- 6.27 Installing position of Damper block (adjust)
- 6.28 X Switch (I230)
- 6.29 ES Magnet (adjust)
- 6.30 Mirror box operation (check)
- 6.31 Apply silicon to Shutter curtain operation lever
- 6.32 Installing Main P. C. Board (T100)
- 6.33 Shutter curtain position (check)

## **7. Mirror base plate (assembly procedure)**

- 7.1 Mirror actuator arm (0-D11)
- 7.2 Restoring gear (D24)
- 7.3 Release spring (D44)
- 7.4 Mirror charge double gear (0-D40)
- 7.5 Operation of Mirror base plate (0-D1) (check)

## **8. Assembly of shutter curtain**

- 8.7 Drawing of shutter curtain assembly

## **9. Main mirror (L1) installing**

## **10. Folding of Main P. C. Board (T100)**

## Disassembly and assembly procedure

NB: In order to prevent static destruction of the inner circuit, use should be made of conductive mats and wrist straps.

### 1. Body I (Disassembly procedure)

Preparations: Set the camera in the released position.

Remove the battery holder, the battery, the body mount cap and the finder cap.

#### 1.1 Grip rubber, body covering

1) Gently peel off A102, then remove A120 beneath it.

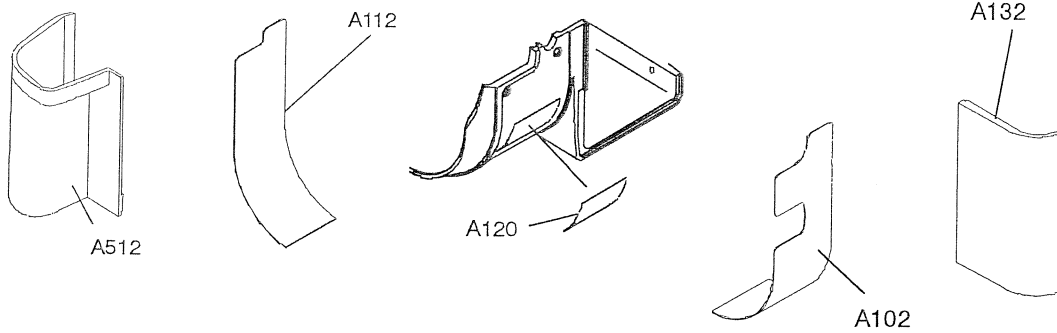

#### 1.2 Bottom cover (A121)

1) 7 screws

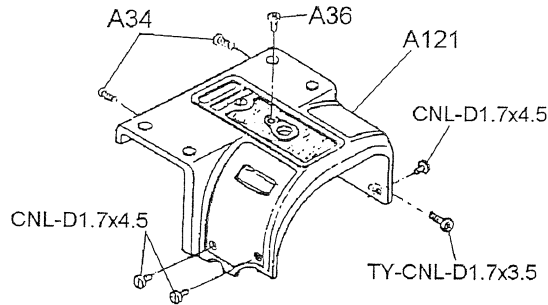

#### 1.3 Rear cover (A321)

1) 4 screws

2) M10 x 2

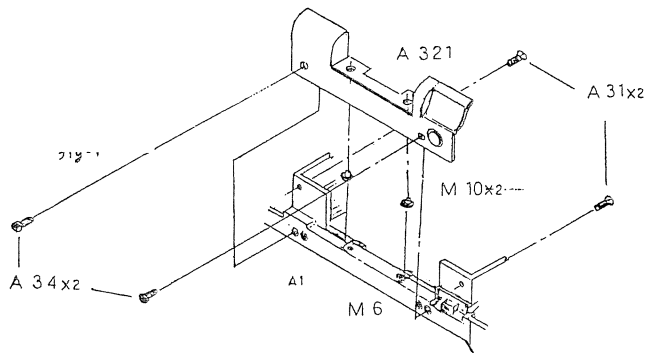

#### 1.4 Focus screen frame (M1)

1) Remove M1 from the back.

2) M6: 2 screws, W2 x2

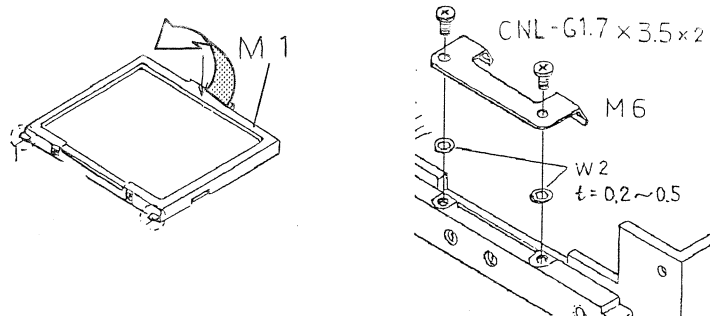

**1.5 Front cover, left (A131)**

- 1) 2 screws

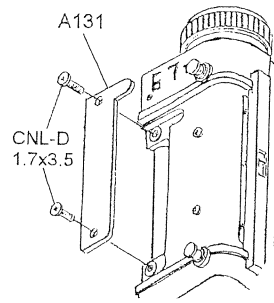

**1.6 Left side cover (0-A101)**

- 1) 3 screws  
 2) Remove 0-A101 as shown in the drawing.  
 NB: A lead wire is attached to the back of the cover.

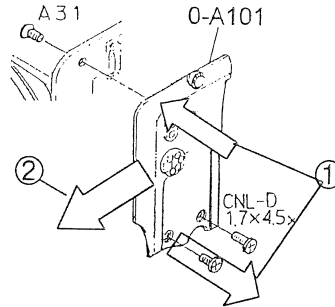

- 3) Remove the soldering of the 6 lead wires on the main circuit board.

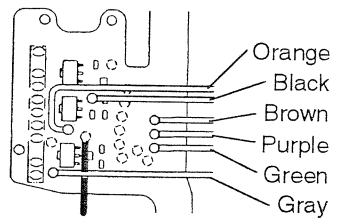

**1.7 Top cover, left (0-A351)**

- 1) A33 x3  
 2) 0-A351  
 \* The shutter dial may be in any position.

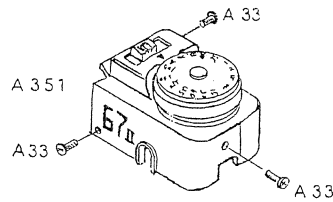

**1.8 Right side cover (0-A111)**

- 1) 4 screws  
 2) 0-A111  
 Lift up the front and pull forwards.

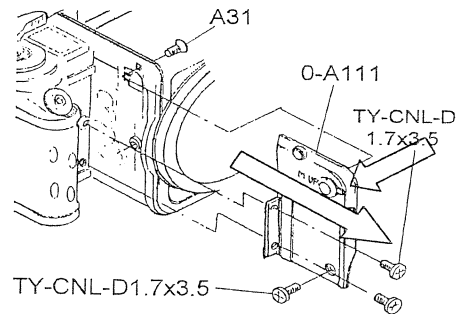

**1.9 Winding lever (C51)**

- 1) C50  
 Wind up half way and peel from the notched groove of C50.  
 2) Wind up fully by C51 and put in the release state. (Use the battery.)  
 3) C51, 3 screws

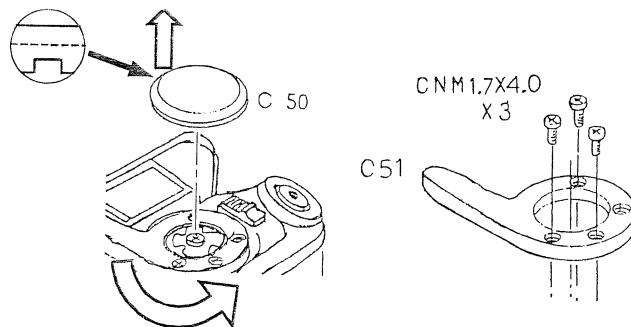

**1.10 Top cover, right (0-A301)**

- 1) A37 (inside battery chamber)
- 2) A32, A33

\*See "Top cover right and related parts" for disassembly and assembly of 0-A301.

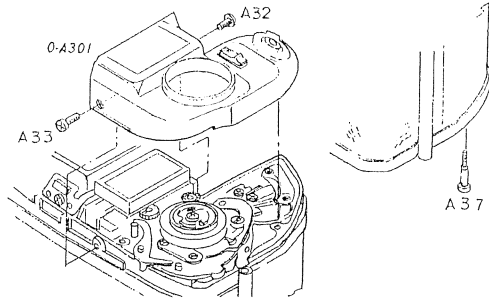

**1.11 Tripod plate assy. (0-B32)**

- 1) 4 screws

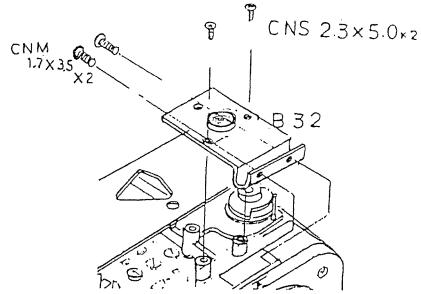

**1.12 Under cover right, left (A401, A451)**

Equipment to be prepared:

: Tool 23400K-A67-A (95901-K145)

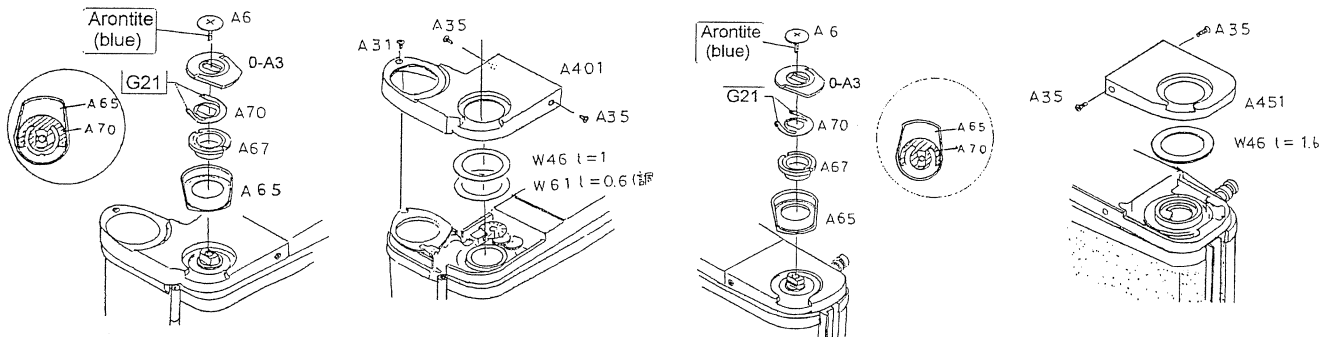

**1.13 Grip (0-A501) and related parts**

- 1) 10 lead wires

- T100 beneath body: 6

- Beneath grip: Black x2 (A510), yellow (A508),  
main switch land section: black (A544)

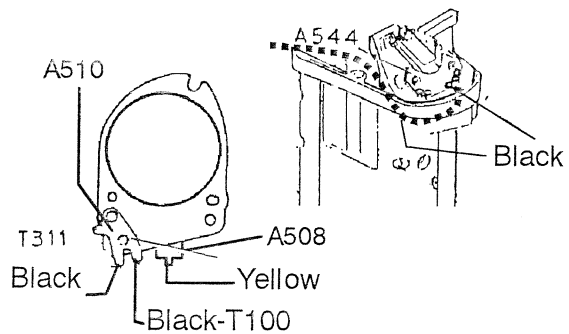
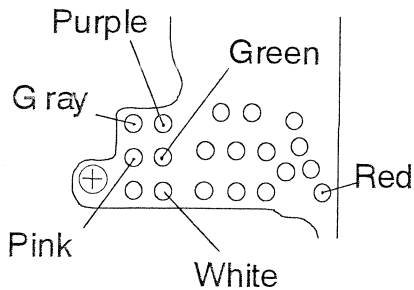

- 2) 4 screws: A515 x2, CNM x2
  - 3) Grip (0-A501) and related parts
- \*See "Grip (0-A501) and related parts" for disassembly and assembly.

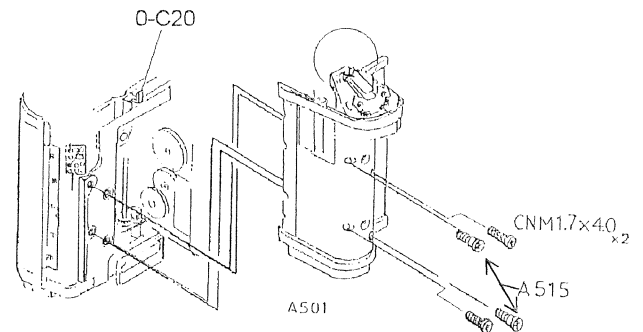

#### 1.14 Lead wires (T100)

- 1) 8 T100 lead wires beneath body
- \*Do not remove the black and yellow lead wires!

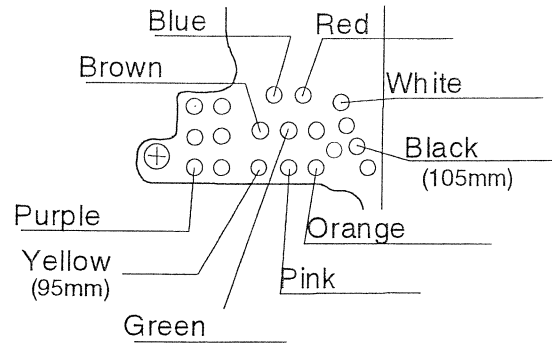

#### 1.15 PCV holder (A87)

- 1) 2 lead wires
- 2) 3 lands
- 3) Peel away the flex of the ISO switch section and the land.
- 4) 3 screws
- 5) A87, N300

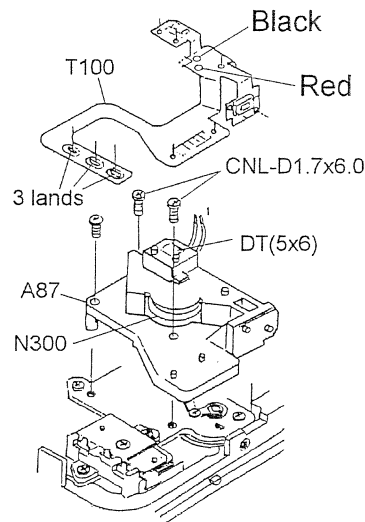

#### 1.16 Back cover switch pedestal (A80)

- 1) Open the Back cover.
- 2) 2 screws
- 3) A80 with switch contacts
- 4) A85

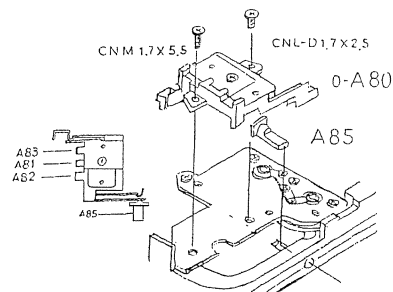

#### 1.17 Rear cover spacer (A322)

- 1) Peel away the flex of the ML button.
- 2) 2 screws

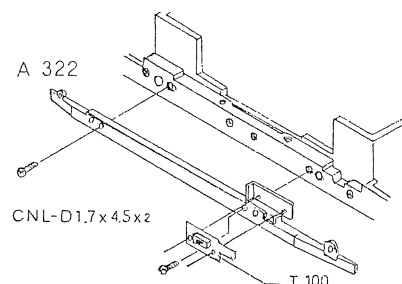



### 1.18 LCD install plate (E101)

- 1) 2 screws of LCD section
- 2) E101, 2 screws

NB: The LCD display section will be free, and care should therefore be taken not to damage it. (The rear screw is omitted from some early mass-produced units.)

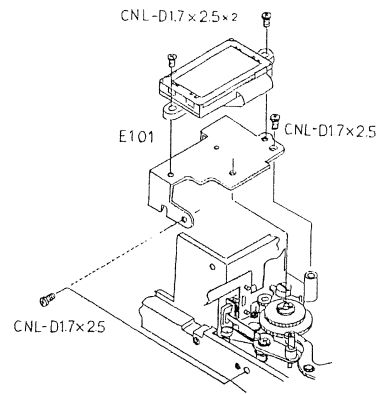

### 1.19 M. E. restrict plate (E88)

- 1) E85
- 2) E88, remove the spring hook.
- 3) Re-attach E85.

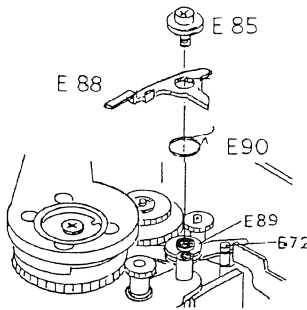

### 1.20 Wind lever click switch

- 1) 1 lead wire (pink)
- 2) CNL-E1.7 x2.0  
C89, C73, C90, C39

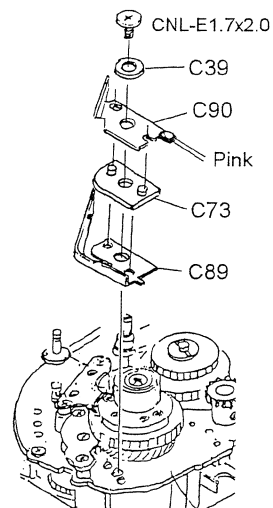

### 1.21 Duality prevention coupler lever (0-C25)

- 1) LW10
- 2) W1
- 3) 0-C25
- 4) C98 (spring)

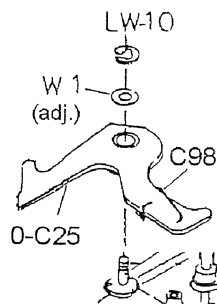

### 1.22 Main gear (assy.) (0-C1)

NB: There are 30 BO1.0 (15 each above and below) between 0-C1 and the shaft. Care should be taken not to mislay them during removal.

- 1) C86, C100, 1 screw
- 2) C27, 2 screws
- 3) C52, 1 screw (remove spring hook)
- 4) 0-C1, BO1.0 x30, remove perpendicularly.

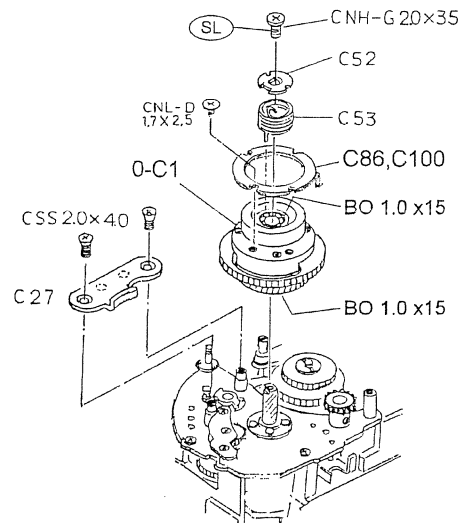

### 1.23 Winding shaft plate (0-C34)

Equipment to be prepared  
: Driver bit 23400K-C73-A  
(95901-K159)

- 1) C33, 3 screws
- 2) C96
- 3) C83, 1 screw
- 4) C37, C35, C40

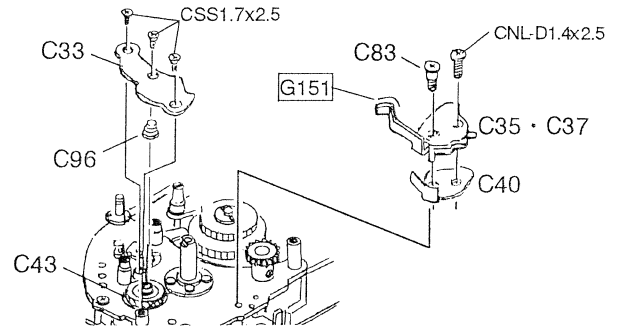

### 5) C84:

- 1) 1 lead wire (orange)  
Remove at 0-T311
- 2) 1 screw
- 3) C60, C84, C85

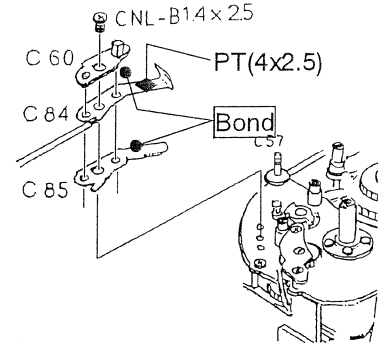
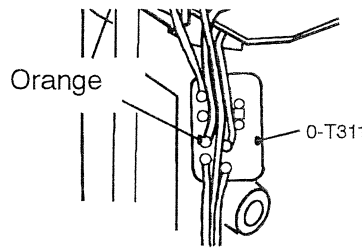

- 6) C2, 1 screw
- 7) 0-C34, C15
  - 1) E93, C57 (use tool)
  - 2) 0-C34  
Remove 0-C3 from bottom.
  - 3) C43, C44

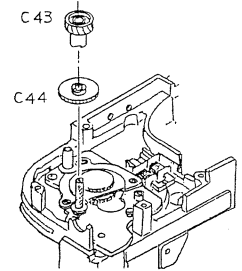
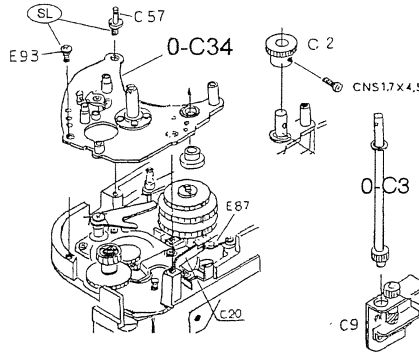

### 1.24 Winding lock interval lever B (0-C26)

- 1) Remove C92 spring hook.
- 2) 1 screw
- 3) C92
- 4) 0-C26  
Free 0-E91 (duality prevention lever) to the rear.  
(Affix on S300 magnet.)  
NB: Do not bend the lever during removal.

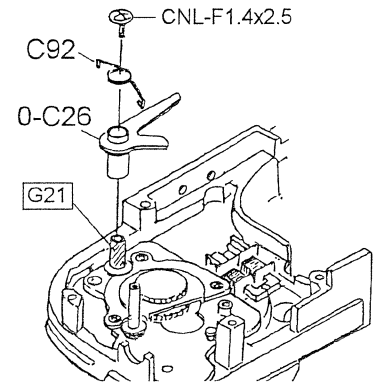
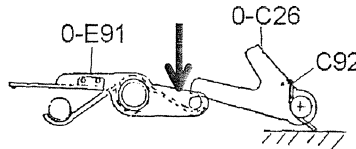

### 25 Mirror box and body II

- 1) 2 C9 screws (CNM..., D147)  
No need to remove C9.

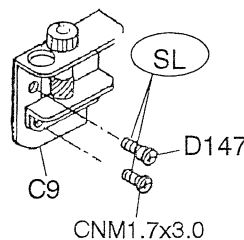

(continued on the following page)

2) Remove 9 screws.

Top: 2

Bottom: 1

Back: 6

NB: There is a washer between  
the body and the mirror box.  
W31 (adj.), W8 (t=0.3)

3) Remove the mirror box by pulling upwards.  
C9 and related parts will come away  
at the same time.

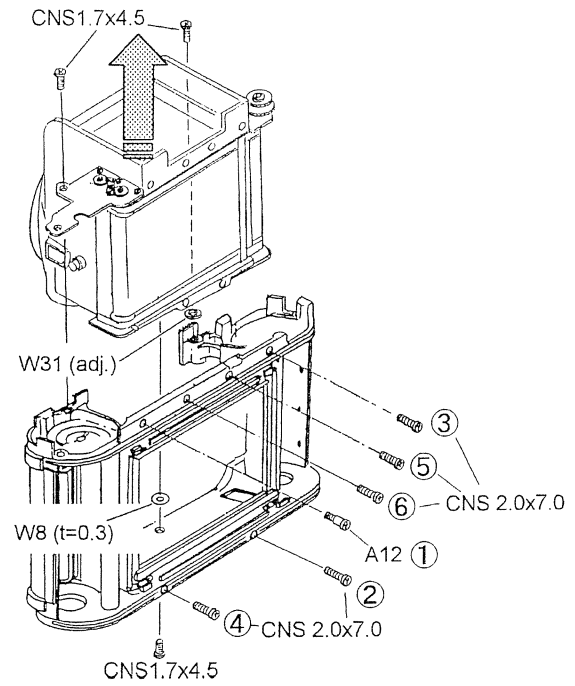
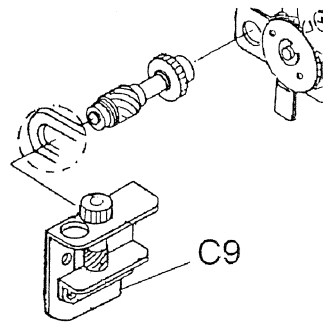

- See "5. Mirror Box" and "3. Body II" for instructions on disassembly and assembly of the mirror box and Body II.

## 2. Body I (assembly procedure)

### 2.1 Mirror box and body II

- 1) Set the shutter curtain to the charge completion state and the mirror base plate (0-D1) to the released state.
- 2) Apply G21 liberally to C9 and the gear sections of related parts.

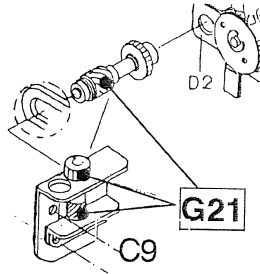

- 3) Fit the mirror box into the body while paying attention to the positions of O-C20 and O-E87. At the same time, temporarily assemble C9 and related parts. (Do not attach with screws.)
- 4) Draw the mirror box to the Back cover key side and attach screws and washers as shown in the drawing. Adjust: W31 should be inserted at the same thickness as the gap between the body and the axial plate (O-E67).

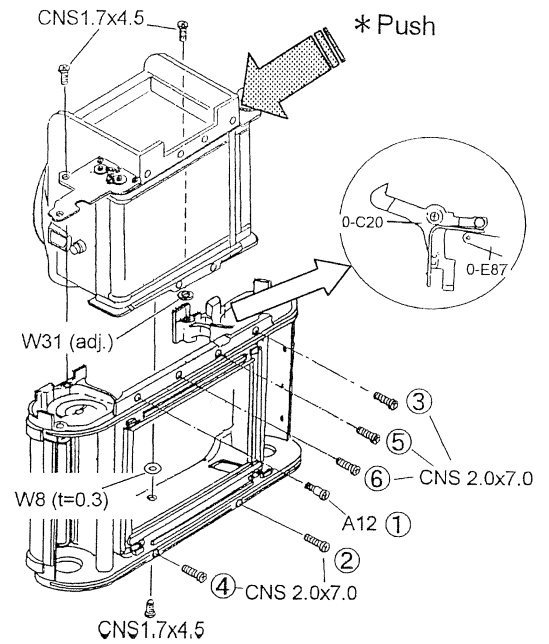

- 5) Arrange the seven lead wires beneath the body.

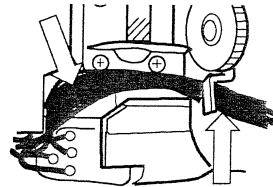

- 6) Attach C9 in the order D147, CNM1.7 x3.0 and apply Screw lock. Check: Check for smooth rotation of the gears.

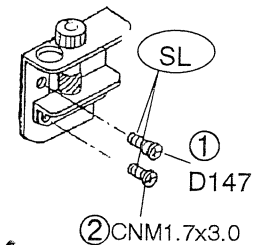

- 7) Apply black paint in order to prevent light leakage. NB: Ensure that the paint does not protrude.

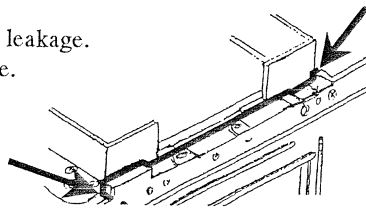

### 2.2 Lock intermediate lever B (O-C26)

- 1) Make it hold the S300 (magnet) and move O-E91.
- 2) Apply G21 to the lever shaft.
- 3) O-C26, C92 (spring), CNL-F1.4 x2.5
- 4) Attach the spring.

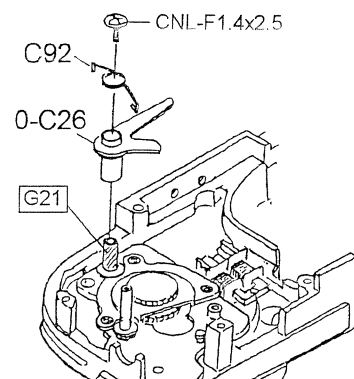
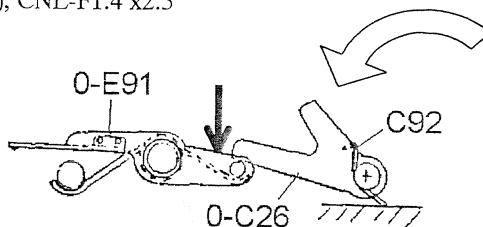

### 2.3 Winding shaft plate (O-C34)

Equipment to be prepared: Driver bit 23400K-C73-A

- 1) Align C44 and C94 (spring) and attach.
- 2) C43 (C43 will come off at this state)

- 3) Attach O-C3 by passing through the body from below.  
(Apply G21 to the gears.)

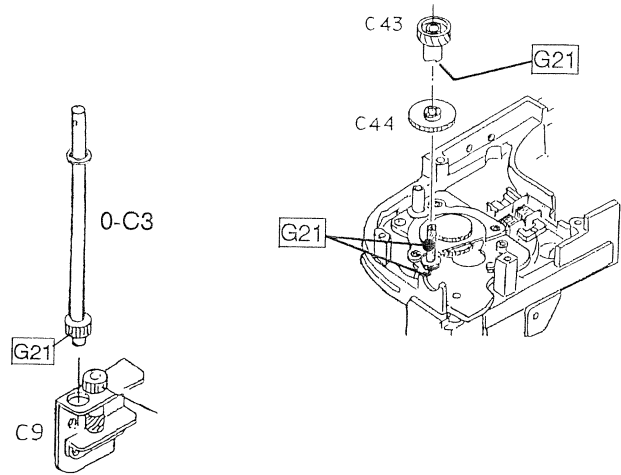

- 4) O-C34, C15 →

(C15 should be thoroughly press-fitted.)

- 5) C57 (Screw lock, tools to be used), E93
- 6) C2, CNS 1.7 x4.5

Check: Check that the gears rotate smoothly.

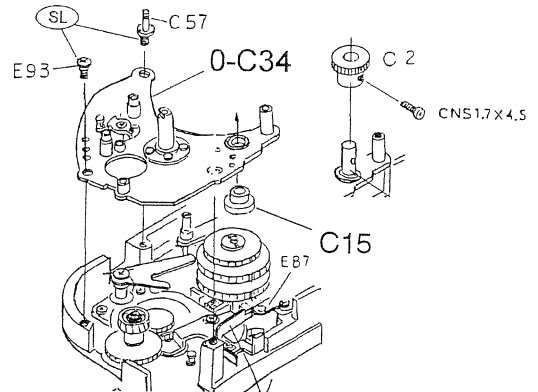

- 7) C85, C84, PT (4 x2.5), C60  
CNL-B1.4 x2.5

- 8) 1 lead wire (orange, O-T311)

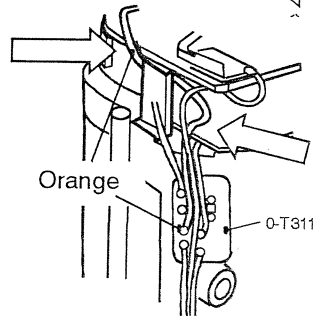
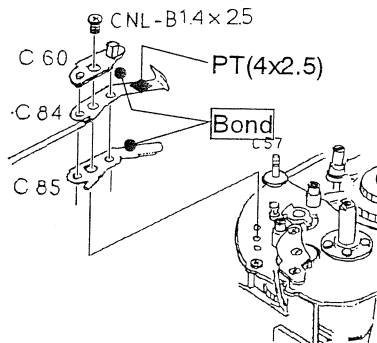

- 9) C40, C35, C37, C83, CNL-D1.4 x2.5  
Apply G151 to tip of C35.

- 10) C96, C33, CSS1.7 x2.5 x3

NB: Make sure that C96 does not intrude while turning C43.

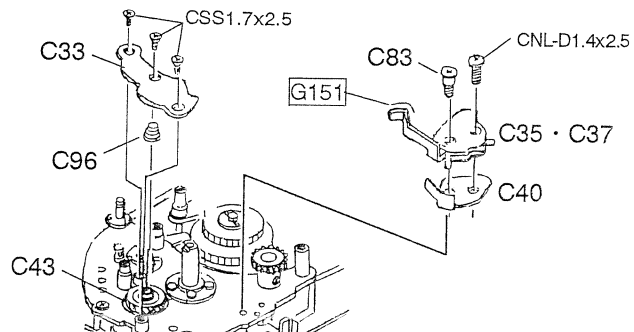

### 2.4 Main gear (assy.) (O-C1)

- 1) Release the shutter curtain.
- 2) Remove O-E80 (curtain charge gear) and O-D43 (mirror charge gear).

NB: Take care not to lose the steel balls.

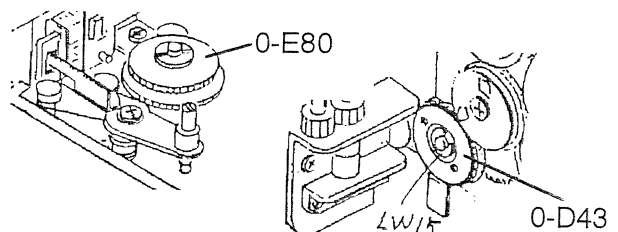

- 3) Apply G31 generously to BO1.0 (15 each above and below) and attach O-C1 (main gear).
- 4) Install O-C1 vertically and attach to shaft while taking care that BO1.0 does not protrude.
- 5) After attaching O-C1 thoroughly, move O-C28 (Winding ratchet) and rotate O-C1 clockwise until it stops.
- 6) C53, C52 (drawn surface on top)  
Attach C53 to the long hole of C52, rotate clockwise 180 degrees, and attach with CNH-G2 x3.5.  
(Apply the Screw lock)
- 7) C86, C100, CNL-D1.7 x2.5  
Move C86 anti-clockwise and fasten the hole at front right with screws.
- 8) Attach the temporary winding lever (C51) to prevent users' items becoming scratched.
- 9) C27 (-O1G: standard use), CSS2 x4.0 x2  
In order to prevent contact with C86, wind the winding lever 160 degrees and attach C27.

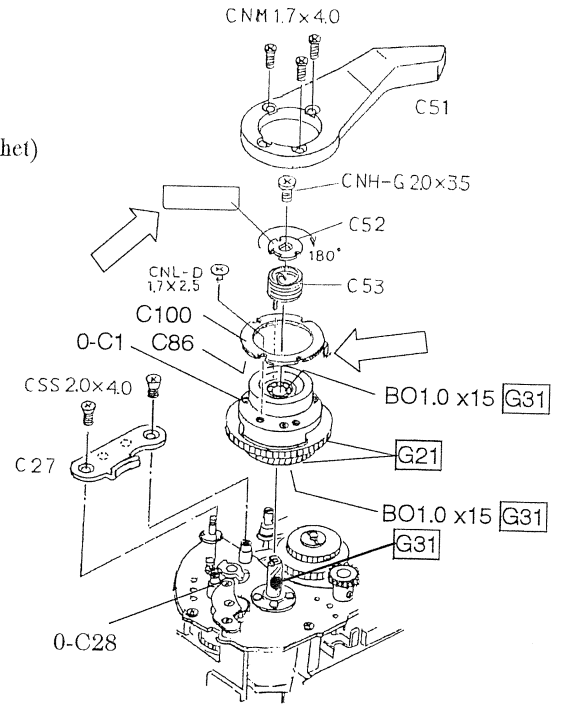

### 2.5 Winding stopper position (adjust)

- 1) Check: Slowing wind with the winding lever and when stopped in a position with the ratchet (O-C28) reversed, check that the gap between O-C1 and C27 is between 0.2 and 0.5 mm.

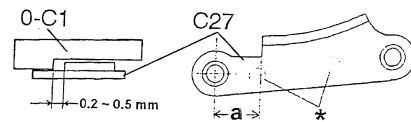

- 2) Adjust: Replace C27 types. →  
C27-O1G, -O1E, -O1F

C27	a (mm)	ID Mark (Left, Right)	
-O1G	4.8	○	○
-O1E	5.0	—	—
-O1F	5.2	○	—

- 3) After adjusting and check, apply the Screw lock to the screw sections of CSS2 x4.0 (2) and check a second time.

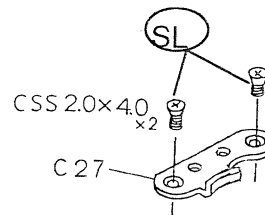

### 2.6 Charge gear position (adjust)

- 1) O-E80 (curtain charge gear)
  - 1) Set the winding lever in the housed state.
  - 2) W51 (t=0.3, adj.)
  - 3) O-E80 (-OOB: standard used), attach so that the dowel at the rear faces true left (Back cover key side).
  - 4) E79 (apply G21 to shaft part of O-E80).

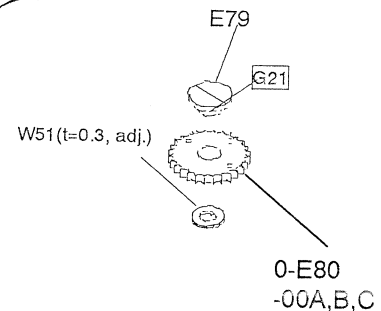

- 2) Check: Slowly wind and check for the following order (①→②→③).  
NB: Do not wind forcibly if there is a large gap between ② and ③.  
The gap should be small. In order to release during winding, hold the winding lever and move the ratchet.

- ① 1<sup>st</sup> curtain stopper (upper E82 stopped)
- ② 2<sup>nd</sup> curtain stopper (lower E82 stopped)
- ③ Ratchet (O-C28) reverses  
(Gap between O-C1 and C27 between 0.2 and 0.5 mm)

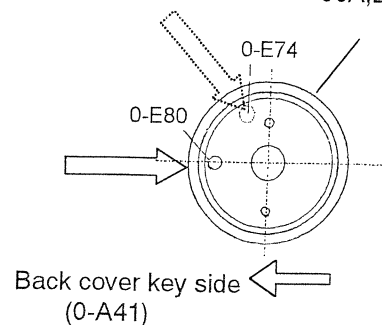

- 3) Adjust: Dislodge the linkage of the O-E80 gears,  
or replace O-E80 with different gear and dowel positions.  
(4 types, same part numbers) →

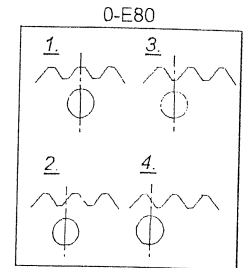

Adjust winding looseness and roughness by replacing with types  
with different diameters.

- Diameter: O-E80-OOA (no sign) > -OOB (one mark-off line) > -OOC (two marks)

### 2.7 Mirror charge quantity (adjust)

- Place the winding lever in the preparatory angle position.
- O-D43 (-OOA: standard use), D6, LW15  
Attach as shown in the drawing while paying attention to the O-D40 dowel and the position of O-D43.
- Check: Slowly wind. When the ratchet (O-C28) has reversed and the winding lever has returned, the Diaphragm charge gear (O-D32) of the mirror box should be positioned on the left.  
(→ Charge completed state of the mirror box)  
Overcharge should occur when wound further up to the stopper.

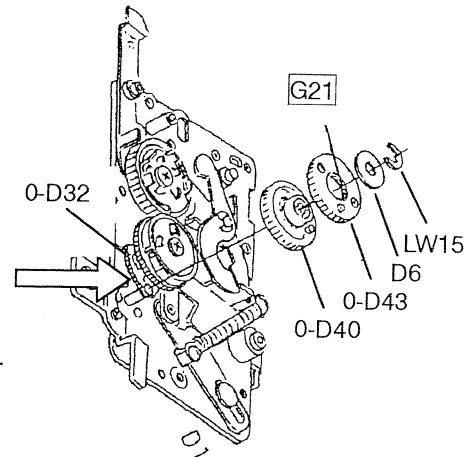
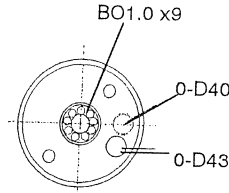

- 4) Adjust: Dislodge the linkage of the O-D43 gears or replace with another type.  
- O-D43-OOA (no mark), -OOB (one mark-off line), -OOC (2), -OOD (3)

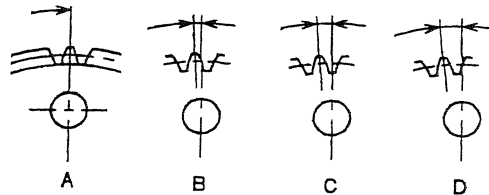

NB: Be sure to apply G21 when replacing O-D43. Make sure that LW15 is not loose.

### 2.8 Duality prevention coupler lever (O-C25)

- C98, O-C25, W1 (adj., 0.1 - 0.3 mm), LW10  
Check: Vertical looseness less than 0.05 mm,  
O-C25 should move smoothly.

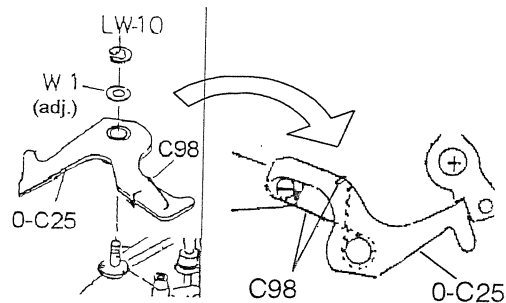

- 2) Adjust: Attachment position of S300.

- Loosen screw CNL-D1.7x3.5 as shown in drawing right, adsorb the armature of S300. (S300 should be free)
- Slowly wind and return. When this is done, the tip of O-E91 should move to the adsorption side of S300 an instant.  
Adjust: Position S300, so that the above moving amount reach to more than two-thirds of the width of the S300 armature hole.

NB: When O-E91 move to adsorption side,  
make sure that it is not distort.  
S300 should not come into contact with the gear.

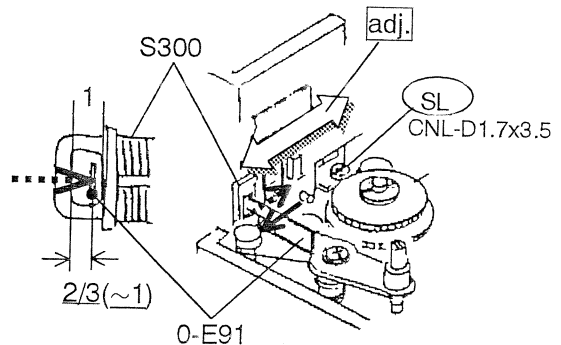

- 3) Check 1: When the armature is released adsorption, the gap between O-C25 and O-C28 should be more than 0.1 mm.  
 Check 2: When winding again, the pointed part of O-C25 should be engaged with O-C28 as shown in drawing.  
 Adjust: Adjust with the eccentric dowel of O-E91.  
 (Do not bend O-E91)
- 4) After adjusting as above, apply Screw lock (or adhesive) to S300 installing screw and o-E91 eccentric dowel.  
 When wind on after adjustment, move O-C25.
- 5) Check: During winding, C97 (ratchet spring) should come securely into contact with C84 (winding half-way switch) 11 (eleven) times.

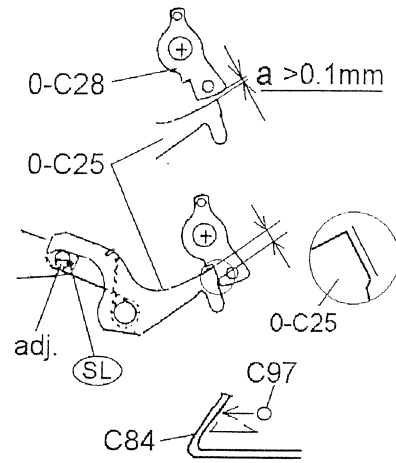

### 2.9 Winding lever click switch (C89, C90)

- 1) Set during winding.
- 2) C89, C73, C90, C39, CNL-E1.7 x2.0
- 3) Adjust: Gap of Winding lever click switch  
 C90 should be adjusted so that the switch gap is between 0.1 and 0.3 mm in the Winding lever is at preliminary angle position.
- 4) Check: Check switch operation.
  - a) Winding lever housing position: SW/off
  - b) Winding lever preliminary angle position: SW/off (0.1 - 0.3 mm)
  - c) During winding: SW/on
- 5) One lead wire (pink) should be soldered onto C90.

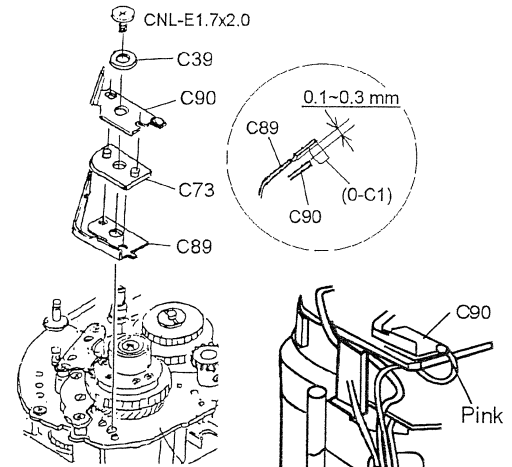

### 2.10 Multiple exposure restrict plate (E88)

- 1) Remove temporarily attached E85.
- 2) E90, E89, E88 (apply G21 to inner diameter).
- 3) E85. Attach spring.
- 4) Check: Catch of C86 and E88 should be more than two-thirds of the plate thickness.

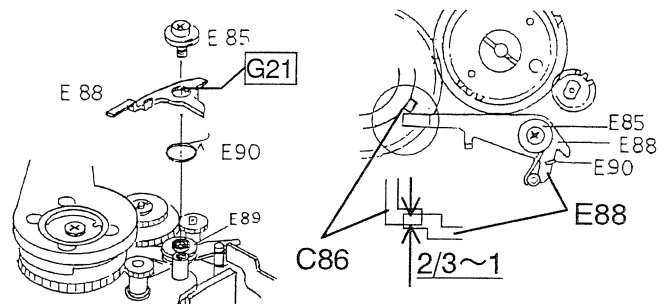

### 2.11 External LCD support plate (E101)

- 1) E101, CNL-D1.7 x2.5 x2  
 (Rear screw was omitted with early mass-produced items.)
- 2) Attach LCD display section of main PC Board.  
 CNL-D1.7 x2.5 x2

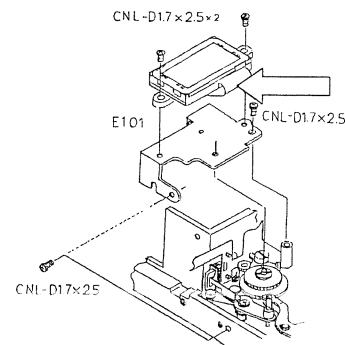

### 2.12 Rear cover spacer (A322)

- 1) A322, CNL-D1.7 x4.5 x2
- 2) Attach ML button flex (T100) to A322.

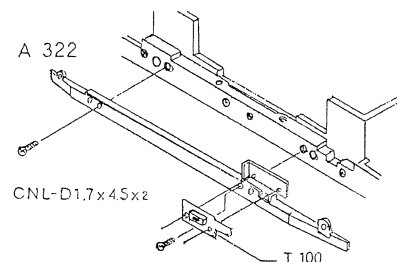



### 2.13 Rear cover switch pedestal (A80)

- 1) Open the Back cover.
- 2) A85
- 3) A80, switch contact.
- 4) Move A80 forward to the left and attach.  
CNL-D1.7 x2.5, CNM 1.7 x5.5
- 5) Check: Back cover switch, pressure plate switch.  
Each switch should go on and off securely by opening and closing the Back cover and switching the pressure plate (120 $\leftrightarrow$ 220).

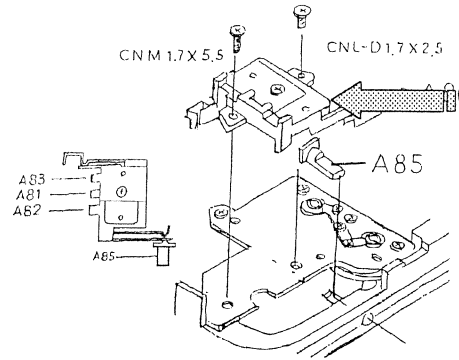

### 2.14 Lead wire (T100)

- 1) Solder 10 lead wires.  
- Lower side of body T100  
O-C102(4)  
O-T311(2)  
C90(1), D72(1)  
Black, yellow (free).

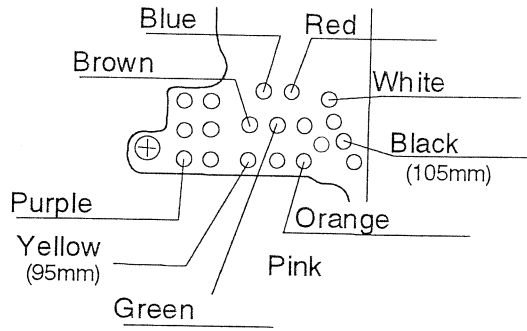

- 2) Treatment of lead wires.

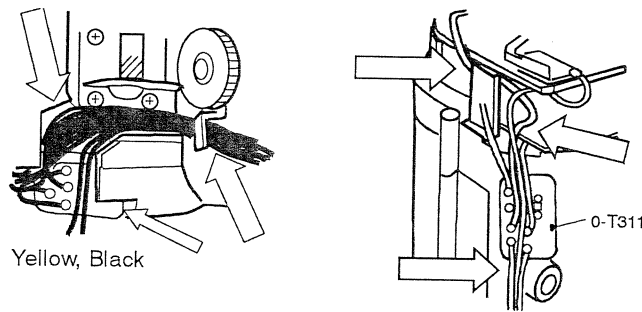

### 2.15 Grip (O-A501) and related parts

- 1) Set the body to the winding completion state.
- 2) Move O-C20 to the outer side (left)
- 3) Attach O-A501 while paying attention to the interlocking of O-C20 (Fig. 1) and insertion of lead wires.
- 4) Move the upper part of O-A501 to the mirror box side and fix the screws in the order of A515 x2 and CNM1.7 x4.0 x2.
- 5) Check: Check that the gap between the contacts of A551 and A552 (multiple switch) is 0.5 +/- 0.3 mm. (Fig. 1)

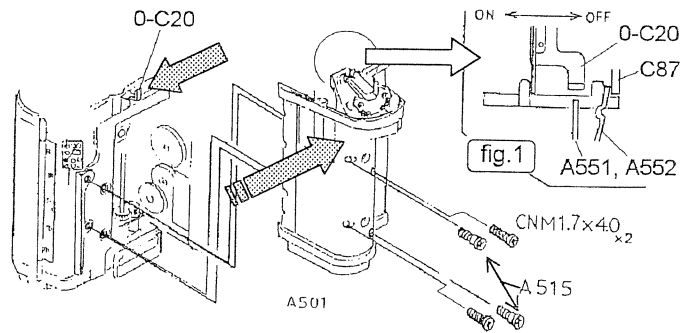

- 6) Solder four lead wires →

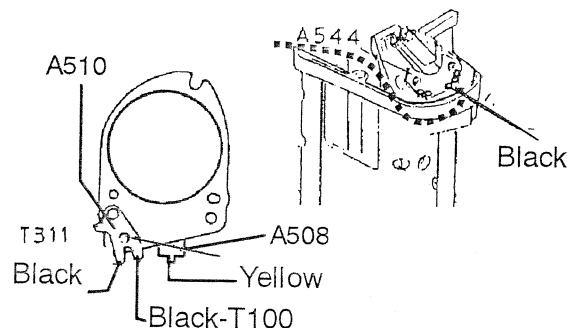

7) Solder 6 lead wires (lower side of body T100).

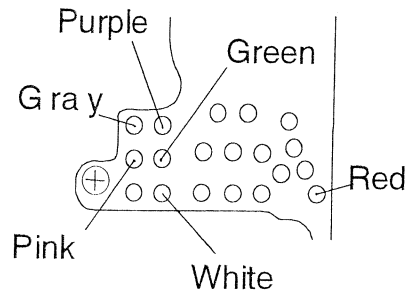

8) Using the guide of the mirror box, treat the lead wires so that they do not come into contact with the gears and the bounce mechanism. →

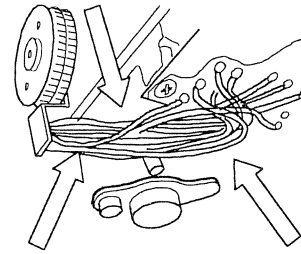

### 2.16 Mechanical back , mirror 45 degrees, mount lock pin (adjust)

Equipment to be prepared: Block gauge for 67,  
Mount pedestal for 67,  
Mirror 45 degree positioning jig for 67,  
Slide calipers.

1) Adjust: Mechanical back

-1) Check: Set the Back cover vertically and measure six places.  
Standard:  $84.95 \pm 0.04$  mm

-2) Adjust: Remove the mount ring and adjust with W8 (four places)  
 $\pm 0.02$  as the objective.

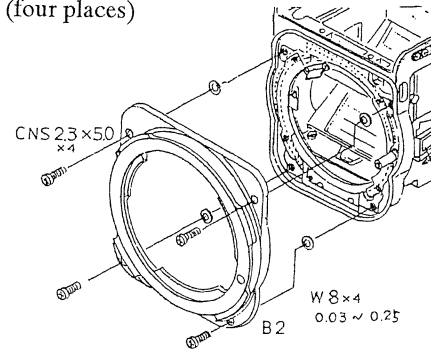
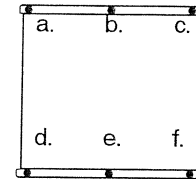

2) Adjust: Mirror 45 degrees

-1) Check: In the winding completion state, place the jig against the mirror and the mount and make sure that there is no gap between the jig and the mirror. (Check in three places.)

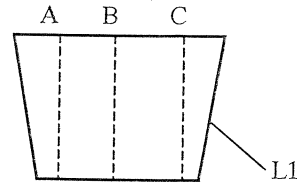
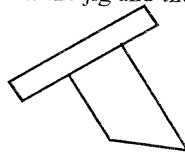

-2) Loosen D149 (2), screw in D148 (2), and create a gap between the mirror sheet and the damper plate (D132, D133).

-3) Adjust 1: Adjust the mirror angle with D148 on the grip side.

-4) Adjust 2: Adjust to zero the gap between the mirror sheet and D133 with the other D148.

-5) Fix with D148 (2) and check again.

After adjusting and checking, apply screw lock D148.

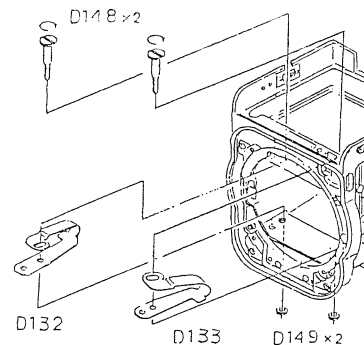

- 3) Check: Mount lock pin  
 -1) Height of mount lock pin.  
 Standard: 0.8 +/- 0.1 mm  
 -2) Height of A/M switch pin.  
 Standard: 1.6 +/- 0.1 mm  
 Adjust: Carry out replacing W43  
 on the inside of mount lock lever.

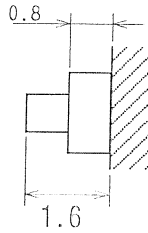

- 3) Check on/off of the A/M switch.  
 1.4 mm → SW/off  
 1.2 mm → SW/on  
 Adjust: With B41. Apply screw lock.

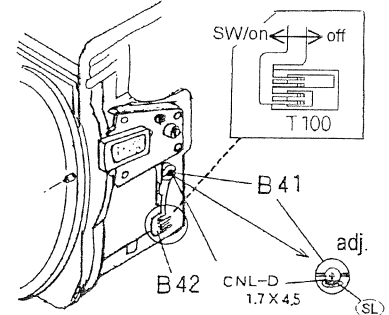
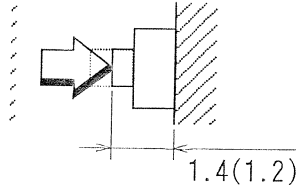

### 2.17 Under cover right, left (A401, A451)

Equipment to be prepared: Screwdriver 23400K-A09-A65-A, Nut driver 23400K-A67-A

NB: Make sure that W61 does not come into contact with the film encoder.

Take care with direction of A3 and A70.

Apply the Arontite (Blue) to the screw part of A6 (2)

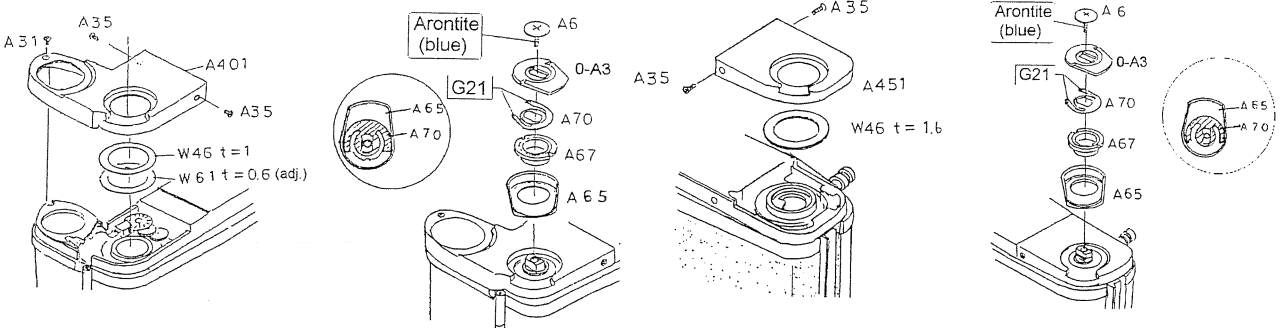

### 2.18 Top cover right (O-A301)

- 1) Remove the winding lever in the housed state.
  - 2) O-A301 (attach straight from above).
  - 3) A33, A32 (short screw),  
 A37 (in the battery chamber)
- \* Tighten screws while depressing O-A301.

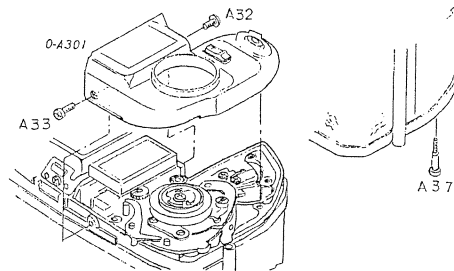

### 2.19 Winding lever (C51)

- 1) C51
- 2) CNM1.7x4.0 x 3  
 (The cover of the winding lever is attached later.)

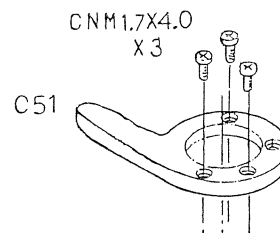

## 2.20 Static current, operation check (check)

Equipment to be prepared: Camera adaptor, constant voltage power supply, ammeter (circuit tester).

- 1) Peel away T18 at the tip of T100 flex for communications use with the battery not inserted.
- 2) Set the constant voltage to DC5.6V (over 3A).
- 3) Bring into contact the camera adaptor, T100 on the body, the constant power source, and the ammeter.

(Red: plus (+), black: minus (-))

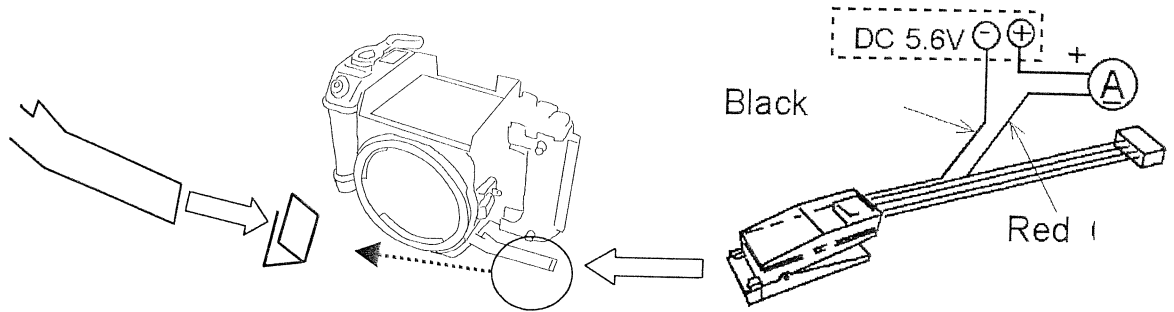

- 4) Attach the battery cover to the body. (Operate the reset switch.)
- 5) Check: Make sure that there is no shorting or leakage in the circuit.
  - \* Static current
  - With main switch off: under  $50 \mu A$ .
  - With main switch on/Meter switch off: Under  $200 \mu A$ .
- 6) Check: Check the LCD display.
- 7) Check: Check winding and release.
- 8) Check: Check multiple exposure.
  - 1) Remove the camera adaptor and insert battery.
  - 2) Open the back cover and make sure that the winding spool is not rotating when the multiple exposure lever is operated and winding occurs.

## 2.21 Curtain speed, shutter speed adjustment (adjust)

Equipment to be prepared: 27340 program software, computer, contact materials, camera adaptor, shutter tester.  
NB: A good deal of running-in is required before adjusting when replacing the shutter curtain.

### 2.21.1 Curtain speed adjustment (adjust)

- 1) Supply power to the body.

(Batteries may be used. Make sure that the red and black wires of the camera adaptor do not short.)
- 2) Set the body onto the shutter tester.

Note: Open the back cover and wind with multiple exposure, Operate the shutter with the bulb.
- 3) Attach the body to a computer with the camera adaptor.

(The method of connection is the same as with the MZ camera or 645N.)
- 4) Run the 27340 program software and select "SHUTTER ADJUSTMENT" as shown below.

```
27340 TEST PROGRAM --- Press key [1]. When replacing T100, press key [2] and adjust the battery level
                        ↓ before going on to adjustment.
CHECK THE CAMERA ---- If A537 is attached to the grip section, press [1]
                        ↓ If it is not attached, press [2]. See 4.3 6) (page 29).
MAIN MENU ----- Press key [1].
                        ↓
SHUTTER ADJUSTMENT
```

[Note] In case of replaced T100, run the EEPROM CHECKING first.

### 5) Curtain speed adjustment (adjust)

- 1) Wind and release by pressing key [1]. ([1]: 1/1000 sec., [2]: 1/500 sec., [3] 1/250 sec.)

Standard: Curtain speed  $22.9 \pm 0.5$  ms (62 mm running, 1/1000 sec., using parallel optical testing device).  
Note: Slow speed operation is possible when the [7], [8] or [9] keys are pushed.  
[7]: 1/4 sec., [8]: 1/2 sec., [9]: 1 sec.

-2) Loosen E-65 installing screw, turn E83 and adjust.

Curtain speed during adjustment:

+/- 0.3 ms (22.6 - 23.2 ms)

Curtain speed difference:

1<sup>st</sup> curtain should be 0.1 to 0.2 ms faster than the 2<sup>nd</sup> curtain.

Note: In the case of an oblique light testing device such as

EF-5000, EF-8000, with 67\_105mm1:2.4,

→ aim 21.2 ms

-3) After adjusting, tighten the screw and confirm again.

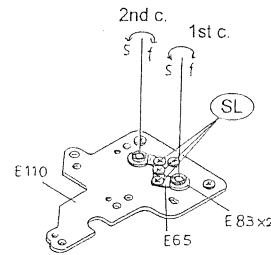

#### 6) Shutter speed adjustment

-1) Release and measure five or more times at each speed at the 'SHUTTER ADJUSTMENT' screen, and find the average value. (1/1000 sec., 1/500, 1/250)

-2) Press the 'Y' key and input the average value into the computer at the next following screen. 'INPUT DATA OF SHUTTER SPEED'

Input example: In the case of 1.23 ms, press the keys in the following order: '1', '.', '2', '3' and 'Enter'

7) Go back to the 'MAIN MENU' and detach from the computer.

8) After adjusting and checking, apply screw lock to the three E65 installing screws.

NB: a) Except when replacing T100, accurate adjustment will be impossible unless measurement is carried out when connected to a computer.

b) T100 flex for connection purposes should be handled carefully so as to ensure that it is not subject to twisting and stress.

c) After disconnecting, if there is 'No LCD display' or 'Release is impossible' are occurred, reset the circuit by removing the battery cover.

#### 2.22 Shutter bounce adjustment (adjust)

1) Adjust: After release, the gap between the stopper of the Damper mech. (AO-E1) should be between 1.5 and 3.0 mm.

Curtain edge should be invisible from the aperture.

2) Adjust: Loosen the install screw of AO-E1 and rotate the inner adjusting nut.

Tighten the install screw (take care not to tighten excessively) and check once again. (During adjustment: 2.0 to 2.5 mm)

3) After adjusting, apply screw lock to the set-screw.

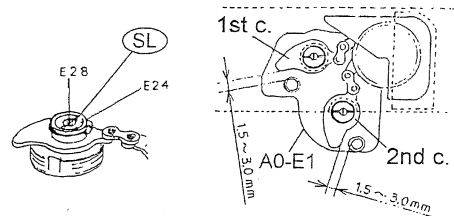

#### 2.23 PCV holder (A87)

1) A87, N300

2) CNL-D1.7 x 6.0 x3

3) Attach the flex with DT (5x6).

4) Solder three lands and two lead wires.

Treat the lead wires between the mirror box.

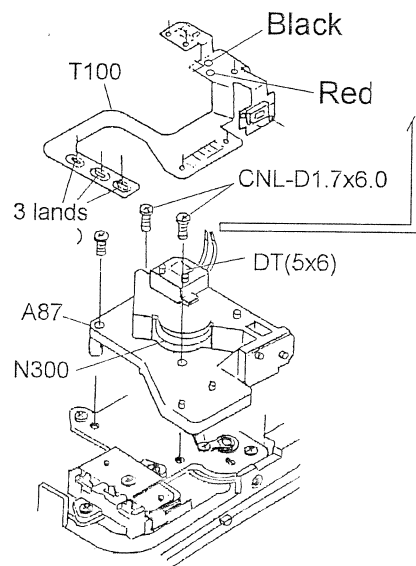

#### 2.24 Right side cover (O-A111)

1) Wipe the land section of T100 (M.UP: mirror up).

2) O-A111

3) TY-CNL-D1.7 x3.5 x3

4) A31

5) Check: Check operation of the M.UP lever.

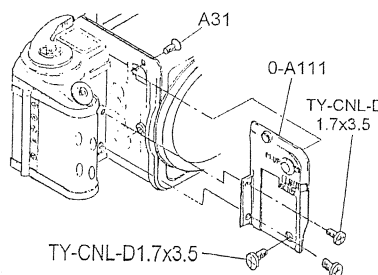

### 2.25 Left side cover (O-A101)

- 1) Solder six lead wires.
- 2) Treat the lead wires so that they do not get caught up and attach O-A101.
- 3) CNL-D1.7 x4.5 x2
- 4) A31

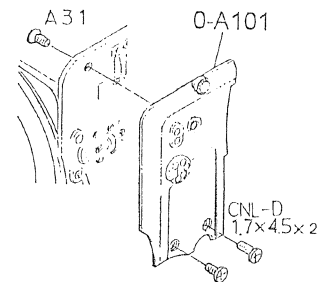
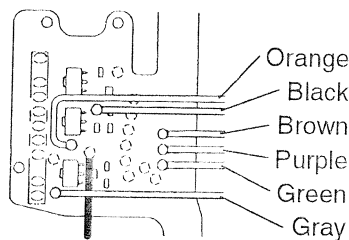

### 2.26 Front cover, left (A131)

- 1) CNL-D1.7 x3.5 x2

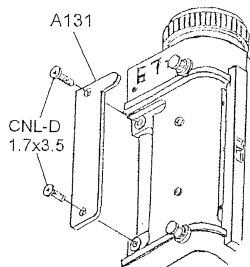

### 2.27 Top cover, left (O-A351)

- 1) Wipe the land and ensure that there is no dirt and that the contacts are not bent.
- 2) Attach O-A351 from directly above.
- 3) A33 x3

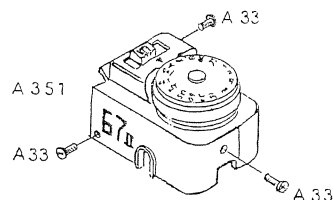

### 2.28 Focus adjustment (adjust)

Equipment to be prepared: Focus standard lens,  
Collimator, loupe, Standard focusing screen (BA-61, BB-61, etc.)

#### 1) Check:

- 1) Operate the shutter two or three times and set to the winding complete state.
- 2) Prevent any looseness of the focusing screen and check the focus at the centre and in the four corners.  
Standard: 0 +/- 0.03 mm  
(focus standard lens: 1 gradation 0.02 mm)

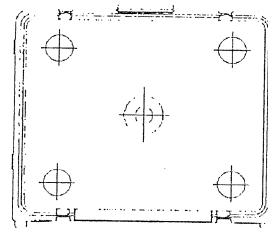

#### 2) Adjust:

- 1) Loosen CNS 1.7 x3.5 (4) and adjust with ST-F2.0 x2.0 (4). (During adjusting: 0 +/- 0.02 mm)  
\* Turn ST-F2.0 x2.0 once and M3 will move 0.4 mm.  
In the case of out of focus toward plus (+) side,  
screw in ST-F2.0 x2.0.  
In the case of out of focus toward minus (-) side,  
loosen ST-F2.0x2.0.
- 2) After adjusting, tighten CNS1.7 x3.5 (4 items) and check again.

- 3) After adjusting and checking, apply screw lock securely to CNS1.7 x3.5 and ST-F2.0 x2.0.

Note: The provisional position of the focus should be one rotation from the contact position of ST-F.2.0 x2.0.

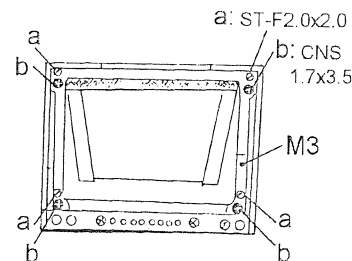

### 2.29 Focus screen frame (M1)

1) Check: Check the gap between M3 on the rear side and the height direction of the mirror box and select W2 in line with the table below.

M3 gap (mm)	W2 thickness (mm)
0~0.2	t= 0.2
0.2~0.4	0.3
0.4~0.6	0.4
0.6~0.8	0.5

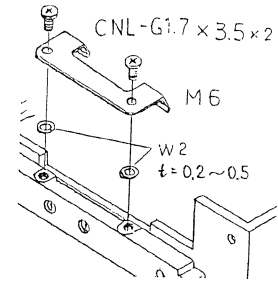

2) W2 x2, M6, CNL-G1.7 x3.5 x2

3) Attach M1 by pushing in from the front.

(Apply L115 to the area which comes into contact with M6.)

4) Check: Check attachment of the focus screen.

Attach and remove two or three times and then attach securely, making sure that there is no looseness, etc.

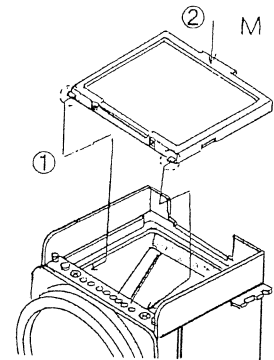

### 2.30 Rear cover

(A321)

1) M10 x2

2) A321

3) A31 x2, A34 x2

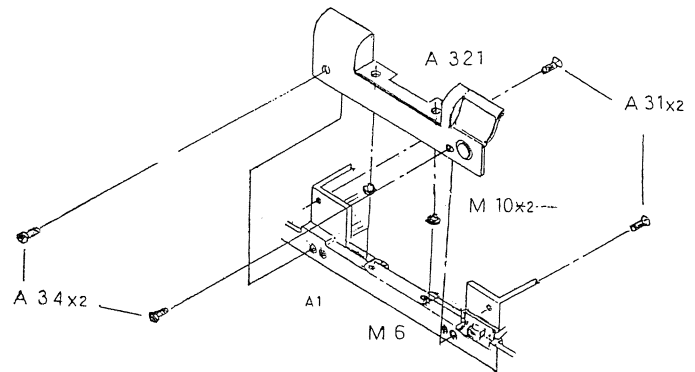
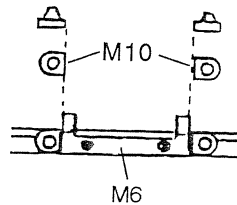

### 2.31 Tripod base (O-B32)

1) Apply O-B32 to the front.

NB: Make sure that the lead wire is not sandwiched in between.

2) CNS2.3 x5.0 x2

3) CNM1.7 x3.5 x2

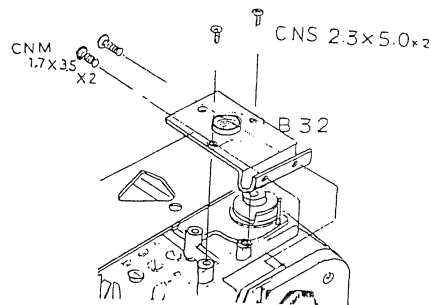

### 2.32 Bottom cover (A121)

1) Pass the flex for the camera adaptor contact through the square hole of A121.

2) A36, A34 x2

3) CNL-D1.7 x4.5 x3

4) TY-CNL-D1.7 x3.5

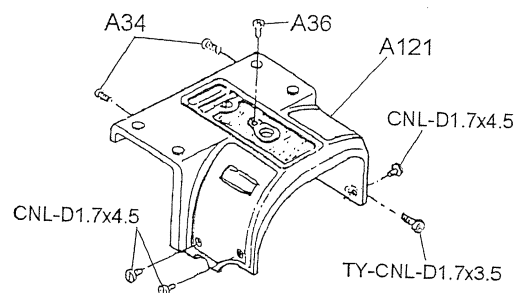

### 2.33 Adjustment using program software (adjust)

Equipment to be prepared: 27340 program software, Computer, Connecting equipment, Camera adaptor, Regulated power source, 67 lens 105 mm F2.4, Shutter tester (for light sources), TTL flash adjustment jig, Thermometer.

#### 2.33.1 Preparations and precautions

- 1) NB: Do not extend the camera adaptor cord or perform wiring likely to have an effect on the electromagnetic waves, etc., of the equipment since this is likely to cause errors in communication with the computer (I/O error).
- 2) When extending the power cords (red, black) of the camera adaptor, adjust and check beforehand with a constant power source in order to ensure that voltage during adjustment (4.50V, 4.20V or 4.30V, 4.00V) comes directly to the adaptor terminal (camera side).
- 3) Place so as to facilitate working by giving consideration to the length of the camera adaptor and the position of the equipment to be used.
- 4) Constant power capacity should be 3A or more in order to enable accurate adjustment of the battery warning level.
- 5) NB: When using a TTL flash adjustment jig, set the pressure plate to 120 and close the Back cover in alignment with the aperture.

#### 2.33.2 Adjustment and checking

- 1) Attach the finder or the finder cover to the body (in order to shield from the light).  
(Note: Attaching the AE finder makes it possible to carry out BV adjustment and to check the display of the AE finder.)
- 2) Connect the body to the computer. (Method of connection the same as with the MZ camera or 645N.)
- 3) Supply power source to the body. (Battery or Regulated power supply. Do not forget to attach the battery cover.)
- 4) Turn on the power of the computer and activate the 27340 program software.
- 6) Adjust and check in accordance with the program software in line with the following procedure.  
(For further details see the software flow chart.)

#### Normal flow

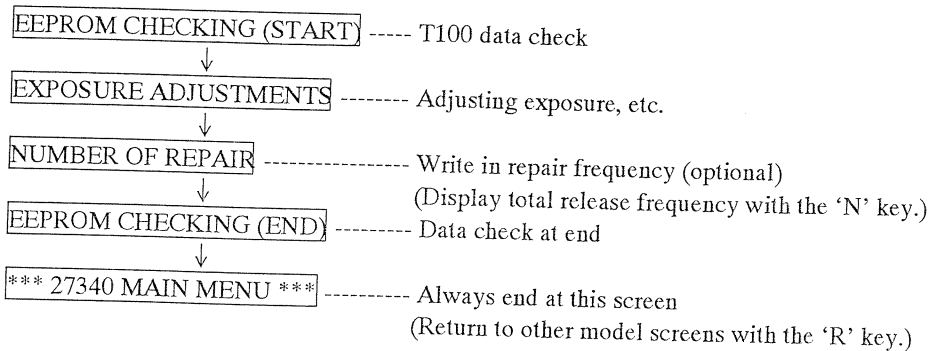

#### Optional

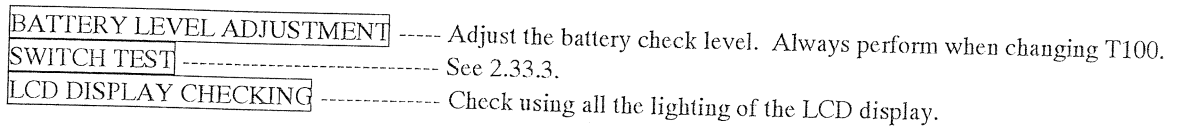

#### 2.33.3 SWITCH TEST (performed as necessary)

Check: Check on/off of each switch with reverse indications from this screen.  
(ON/OFF checks are performed every second. For details see the software flow chart.)



### 2.34 Grip rubber, Body covering

1) C50 (notched section on LCD window side)

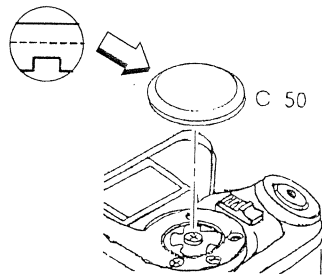

2) Remove the battery and stick T18 to the tip of the T100 flex.

Push in the flex from the root in the direction of the tripod base and leave the tip.

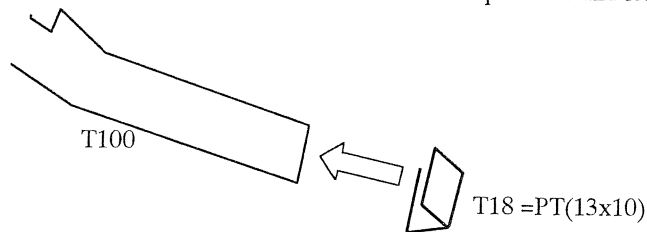

3) Stick A120 to the tip of the T100 flex and attach to A121.

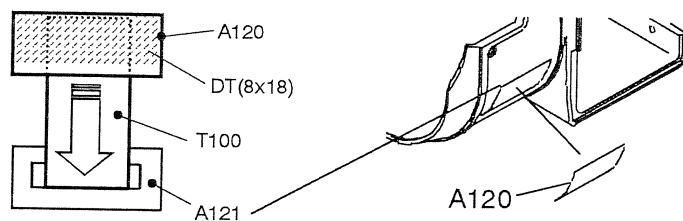

4) Grip rubber, Body covering

NB: Attach securely so that there is no misalignment or looseness.

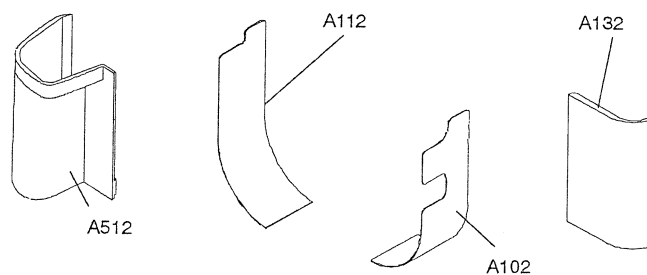

### 2.35 Application of black mat paint

Set to time exposure and apply black mat paint to arrowed area inside the mirror box from the rear.  
Apply also to shiny areas such as areas where the paint has come off.

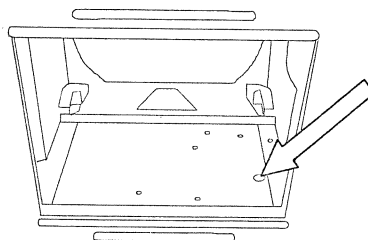

### 2.36 Inspection guidelines (check)

#### 1) Winding check

- 1) Check on operation of the winding lever click angle at pull-out and housing.
- 2) Check on catching and faults during winding.
- 3) Check during return of winding lever.

#### 2) Curtain speed, shutter speed

- 1) Curtain speed: 22.9 +/- 0.5 ms (1/1000 sec. during 62 mm running. Parallel light testing device used.)  
(Ref.: 24 ms / 69.5 mm during running.)

#### -2) Manual shutter speed (standard)

1/1000	0.74~1.53 ms
1/500	1.53~2.58 ms
1/250	3.17~4.81 ms
1/60	13.6~17.9 ms
1/15	56.3~69.3 ms
1/4	225~277 ms
1	901~1,110 ms
X	31.2~41.2 ms

#### -3) Exposure unevenness

Difference during exposure at 2 random locations: 0.45 EV or less

Difference between aperture center and one other location: 0.35 EV or less

#### -4) Auto-shutter speed (reference values)

LV 15	1.48~2.58 ms	±0.4 EV
12	12.7~19.2 ms	±0.3 EV
6	812~1231 ms	//

(With standard lens jig and standard AE Penta jig. Not supplied by the service department.)

#### 3) X time lag:

1<sup>st</sup>: 1.2 ms or over

2<sup>nd</sup>: 3.3 ms or over

(1/30 sec., 62 mm running)

#### 4) Flash firing check

Attach the flash unit to the body and ensure that it fires without lacking of exposure at the shutter dial X or 1/30 position.

#### 5) Mirror operation check

- 1) Press the mirror sheet with the fingers, release the shutter with B (bulb) and raise slowly.

When this is done, check that there is no catching and that it does not stop halfway.

- 2) Place the camera upside down, release the shutter with B, and wind up again.

When this is done, check that the mirror does not rise.

#### 6) Back cover opening and closing check

The back cover should open and close smoothly when opened and closed several times. There should be no creaking noises or any other unusual noises. The cover should not come into contact with the top and under covers.

#### 7) Check rollers on each part

- 1) Check that there are no rotation faults, creaking or looseness when the rollers on each of the parts of the body and inside the back cover are rotated.

- 2) Make sure there are no scratches or dirt which might effect the film on the rollers of film plane and counter rollers.

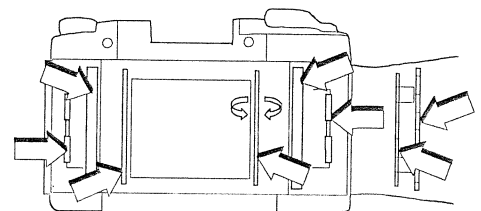

8) Diaphragm coupler ring (0-K102)

Rotate the Diaphragm coupler ring (0-K102) and make sure that it moves smoothly and returns to its original position.

9) Finder attachment and removal

- 1) When the finder lock button is operated, there should be rotation and thrust pressure.
- 2) When the finder is removed and attached, there should be no looseness to attachment and lock cancellation should take place without undue strain.

10) Film transport, Multiple exposure

When shooting with the 120 or 220 film aligned with the prescribed start mark, the number of shootable exposures, the start of the first frame from the start mark, and the distance to the end of the final frame should satisfy the conditions specified below. There should be no misalignment of the image when carrying out multiple exposure photography.

Number of shootable exposures

120 film: 10 frames

220 film: 21 frames

Position of picture:

	a	b
120 film	211 mm or over	981 mm or less
220 film	211 mm or over	1791 mm or less

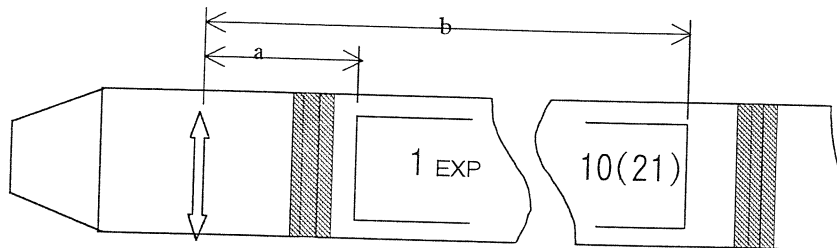

### 3. Body II

- Disassembly and assembly should be carried out in accordance with the following description and with reference to the parts list disassembly drawing.

[Precautions when assembling]

#### 3.1 Application of L114

Apply L114 (oil barrier) to the spool shaft, the film roller attachment sections (upper and lower), and the areas marked in the drawing with an asterisk. (In order to prevent oil seeping into the film chamber.)

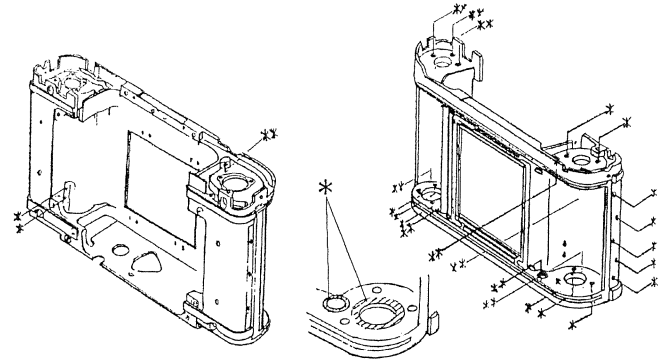

#### 3.2 Film retainer roller parts

- O-A48, O-A49  
Check operation of the hinges.
- A18  
Vertical looseness should be within a range of 0.1 to .02 mm.

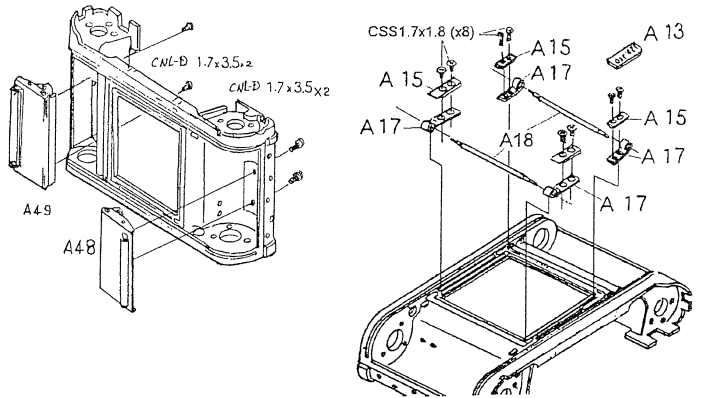

- A61, A64

Apply G21 and L114 to the areas in the drawing.

- Check: Make sure that the above rollers are rotating smoothly.

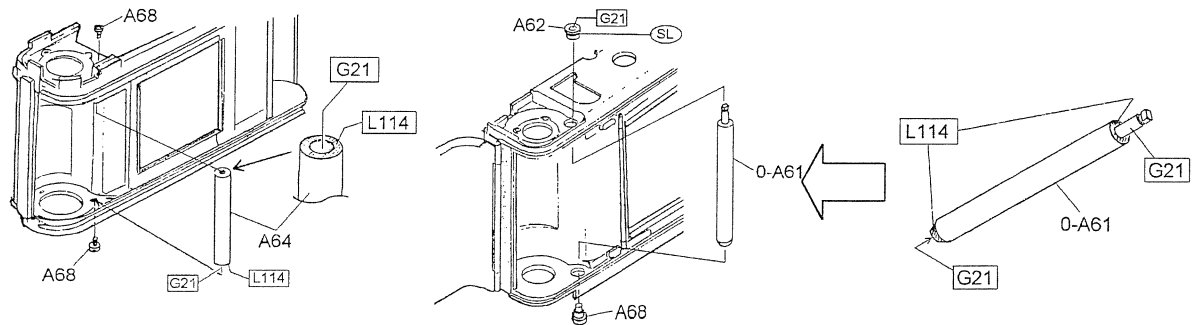

#### 3.3 Back cover key, Back cover (assy.) and related parts

- Check: Make sure that the tip of the O-A75 lever does not come into contact with the body.
- Check: Open and close the Back cover and make sure that it is functioning smoothly.  
Adjust: Contact of the Back cover key should be adjusted by replacing A86.  
A86-OOA (t=0.2),  
-OOB (0.3)

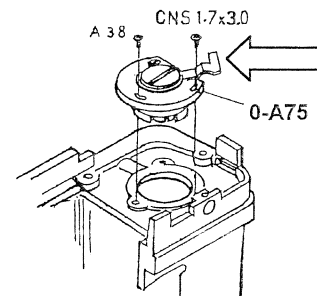

- Check: Check rotation of the Back cover rollers and switching of the pressure plate (120 ↔ 220).

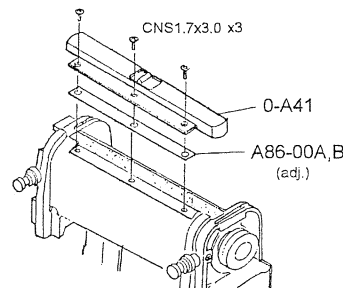

### 3.4 Winding Mg, spool shaft and related parts

Equipment to be prepared: Circuit tester,  
27340-0-C30 check jig

- 1) Check: Check disconnection of S300.  
The resistance value at both tips of S300 should be 10 ohms.
- 2) Assembly procedure
  - 1) S300  
Treat the lead wires as shown in the drawing.
  - 2) O-C30, 4 screws

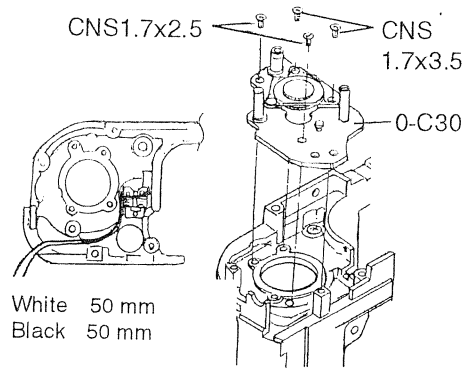

### -3) O-C20 and related parts

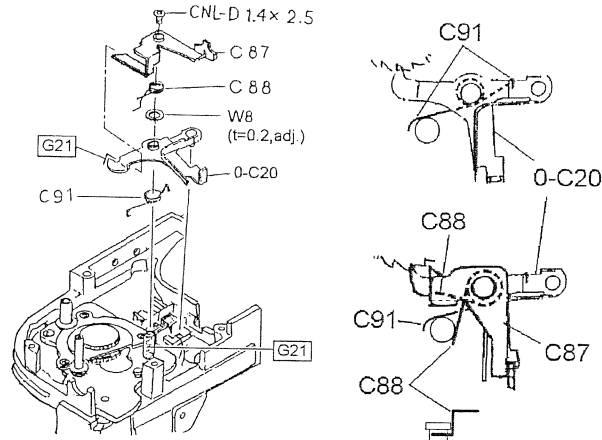

### 3) Check: O-C30 check

- 1) Attach C44 (align the groove with C94 spring), and check for smooth rotation with the jig.
- 2) Remove adsorption of S300 and latch the spool gear with O-C20.
- 3) When rotating quickly with the jig, the catch should not become detached and the spool gear should not rotate.

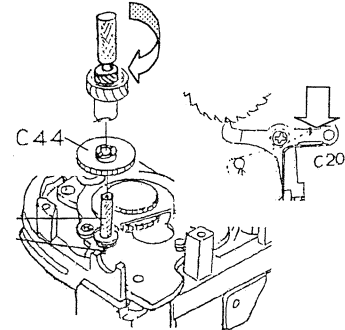

### 3.5 Film pulse parts

[Assembly procedure]

- 1) C105
- 2) O-C102 (T321, T322), 2 screws
- 3) Check: Make sure that O-A61 (counter roller) is rotating and that the gears are smoothly turning.

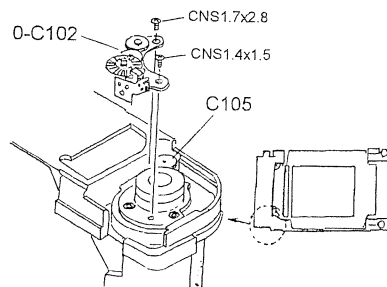

### 3.6 Soldering lead wires and treatment

- 1) 2 lead wires (black, white) ↓  
A300 ---- O-T311

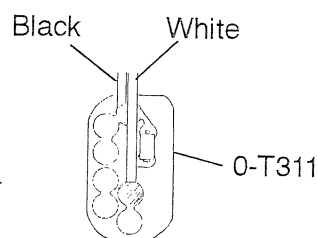

- 2) Treatment of lead wires →  
Black, orange, white  
Pink (free)

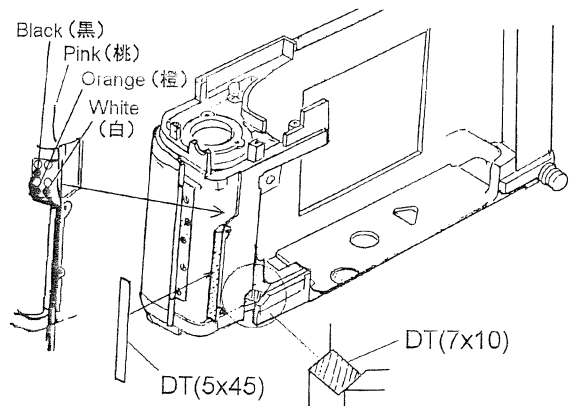

#### 4. Body unit parts

- Disassembly and assembly should be carried out in accordance with the following description and with reference to the parts list disassembly drawing.

##### 4.1 Upper cover right (A301) and related parts

[Assembly precautions]

- A301... Apply G126.
- A305... Apply G126.

Attach by moving in the arrowed direction in the drawing.

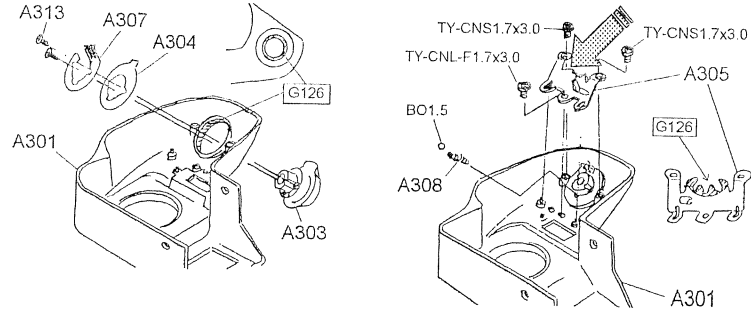

- Main SW dial (A303)

Check: Check operation of the dial.  
(L ↔ ON ↔ Self-timer)

- A306, A309 (release button)

Fix the area in the drawing with adhesive.

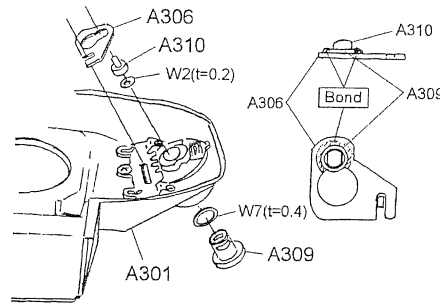

- A311 (multiple operation lever)

- Apply L115 to A301.
- Attach A314 (spring).

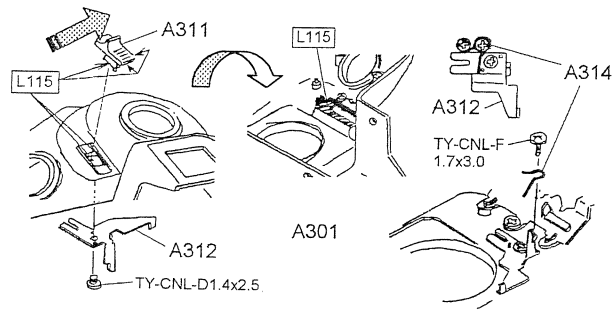

##### 4.2 Top cover left (A351) and related parts

[Assembly precautions]

- A358 (Tv dial stopper plate)

Apply G134 and attach by moving as shown in the drawing.

- A351... Apply G134 and L115.

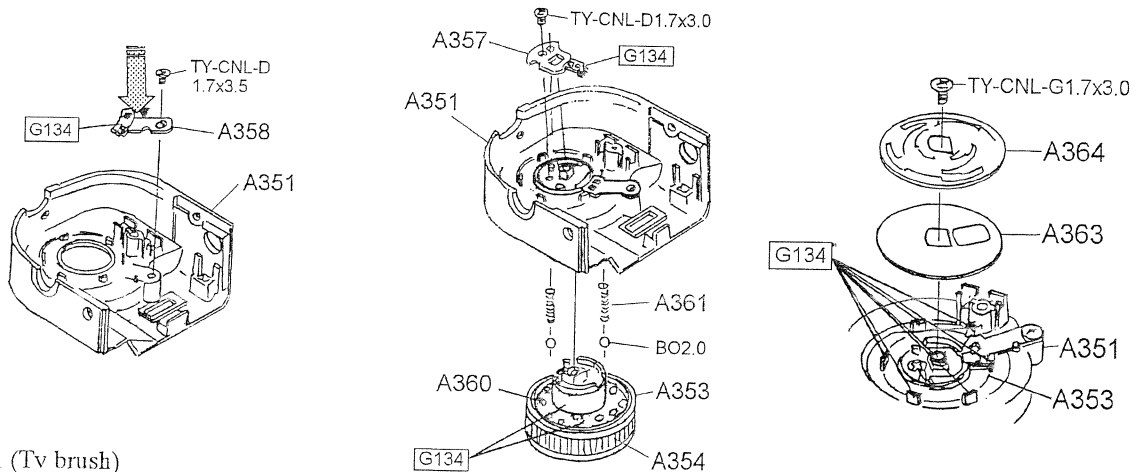

- I221 (Tv brush)

Check: Turn the Tv dial and make sure that the brush is coming securely into contact with the whole land circumference.

### 4.3 Grip (assy.) (O-A501) and related parts

[Assembly precautions]

1) A514 (Battery contact), 1 red lead wire (130 mm)

2) O-A502

-1) Affix PT (5x5) and PT (8x10) as shown in figure..

-2) Apply G134 to the moving part and pointed part of figure.

-3) Attach A509 as shown in the drawing.

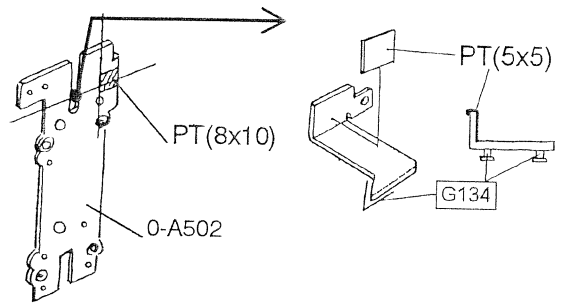
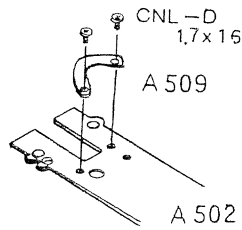

-4) Attach O-A501.

NB: Tighten the 4 screws diagonally. →

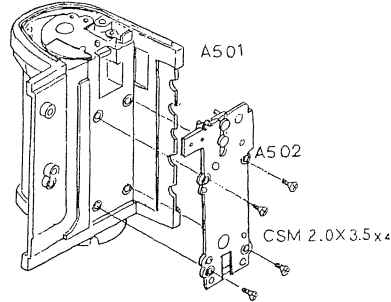

3) A508, A519

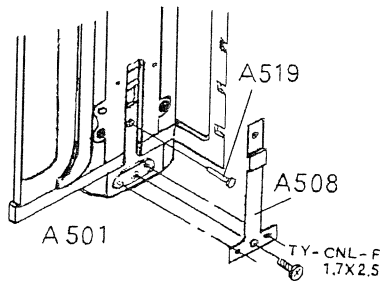

4) A536, A535

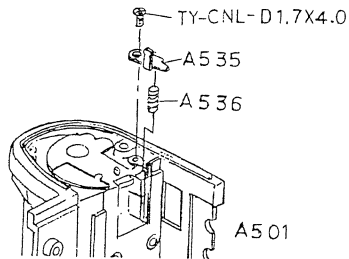

5) A537

(NB: Not used in early mass-produced units.)

Check: Check that the linkage lever operates smoothly when the two batteries (CR123A) are inserted and removed from the battery chamber.

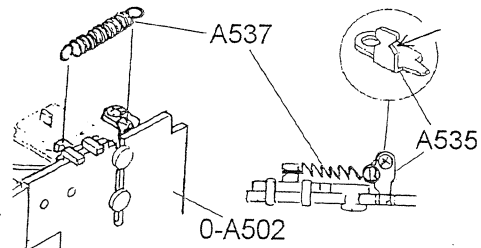

6) A541 (release SW stand)

Soldering and treatment of lead wires

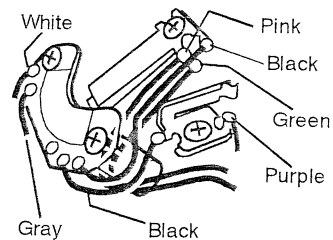
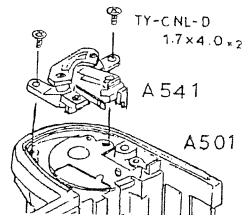

7) Treatment of 6 lead wires on the back of the grip →

8) Attach A513 with adhesive.

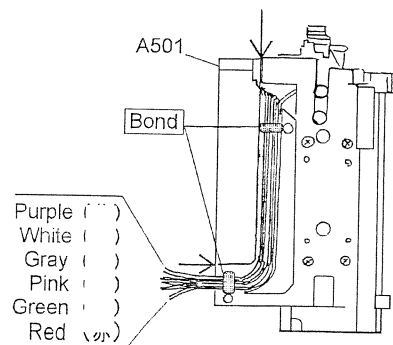
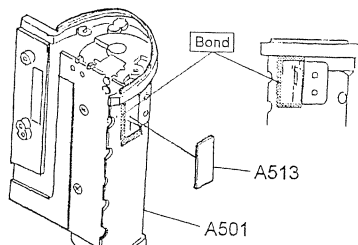

## 5. Disassembly of mirror box

1. Remove CNL-D1.7 x2.0 x2; B21 (focus screen SW contact), B22 (focus screen SW pin) x2.  
Remove CNL-D1.7 x2.0 and lift up T100 – 0-T301

Soldering

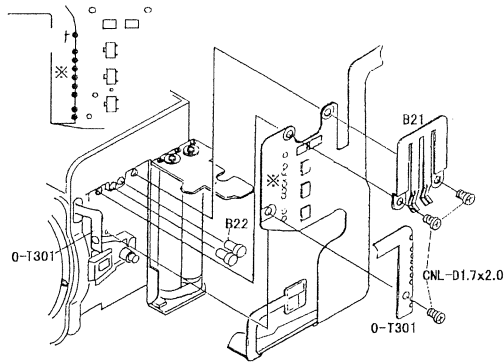

2. Remove CNL-D1.7 x4.5; B41 (AM SW collar), B42 (AM SW), B43 (AM SW spring).  
Remove CNL-D1.7 x3.5; O-B36 (lock-pin guide assy.).

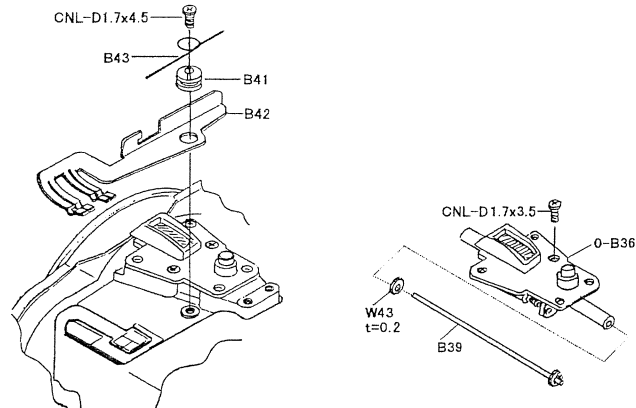

3. Remove CNL-D 1.7 x3.5, CNL-F 1.4 x2.5, S300 section (winding magnet), O-E91 (duality prevention lever assy.), O-E95 (duality prevention lever spring).  
NB: Take care not to bend the plate spring section of O-E91.

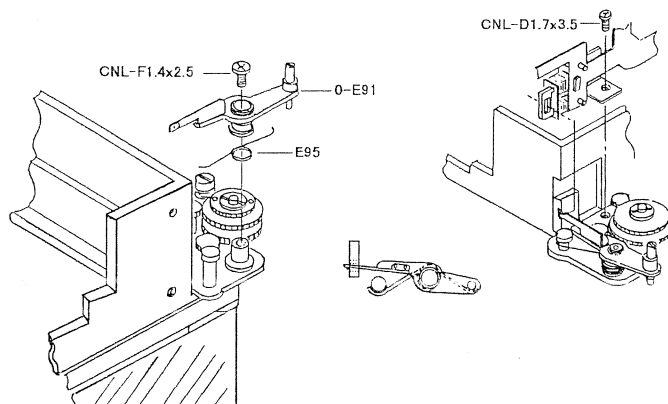



#### 4. Detach T100 (main P.C. board)

##### Unsoldering.

- ① 3 Lead wires, black, blue and brown.- K101 (Resistor)
- ② 2 land areas O-J201 (Light sensor)
- ③ 1 land area J230 (X contact)

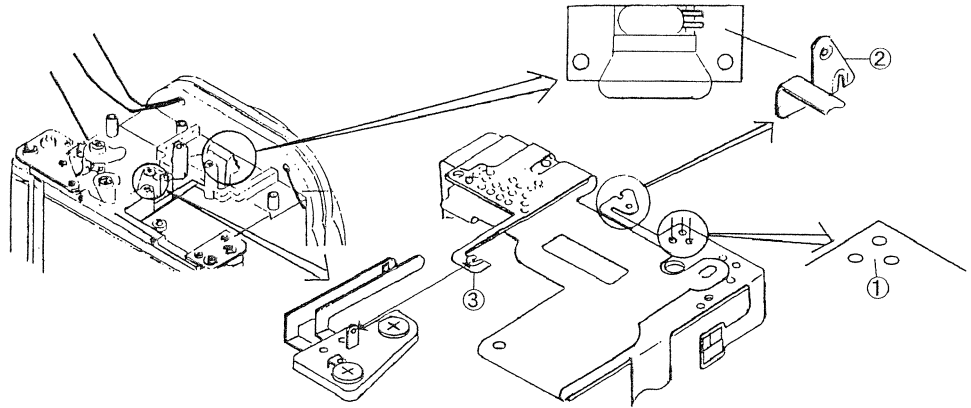

- ④ 9 land areas O-T301 (Viewfinder contact board)
- ⑤ 5 land areas T331 (Shutter magnet relay P.C. board)
- ⑥ Remove from guide sections of D37 (FPC install plate) and D59 (magnet plate).
- ⑦ T3 (FPC retainer screw), CNL-D 1.7 x2.5 x3, Peel off double-sided taped section and remove T100.

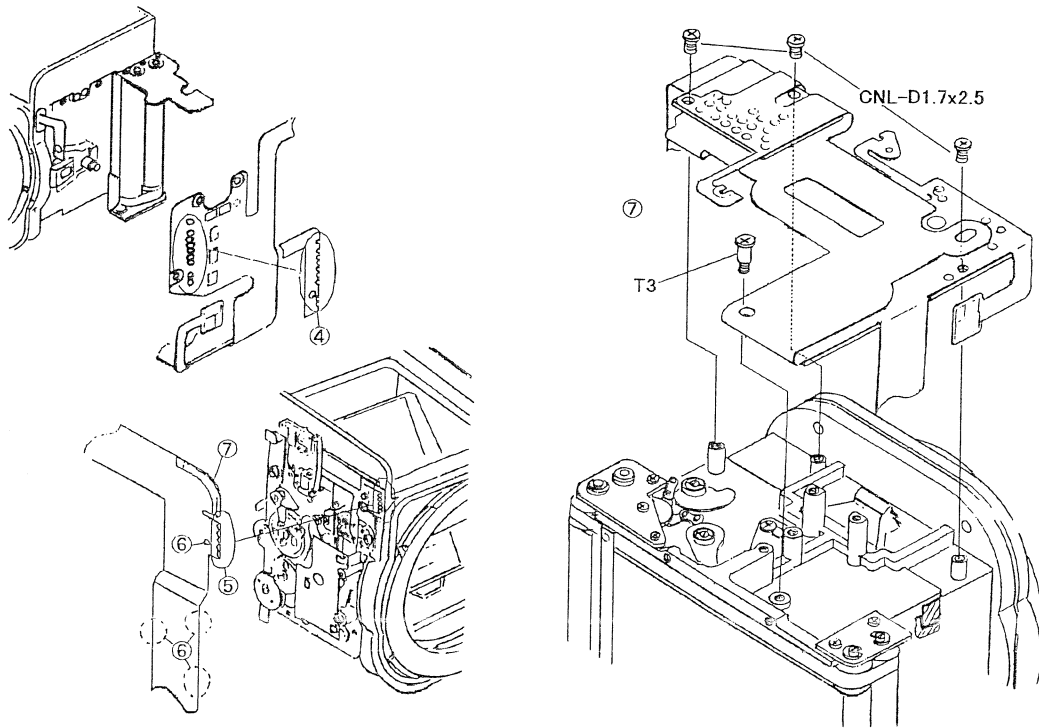

5. Remove CNL E 1.7 x9.0, O-D57 (1st curtain lever assy.); O-D55 (2nd curtain operation lever assy.), D56 (1st curtain release spring), D52 (Shutter curtain stopper hook collar), D54 (2nd curtain release spring), remove CNL-D1.7 x1.6, CNL-D1.7 x2.5; D37.

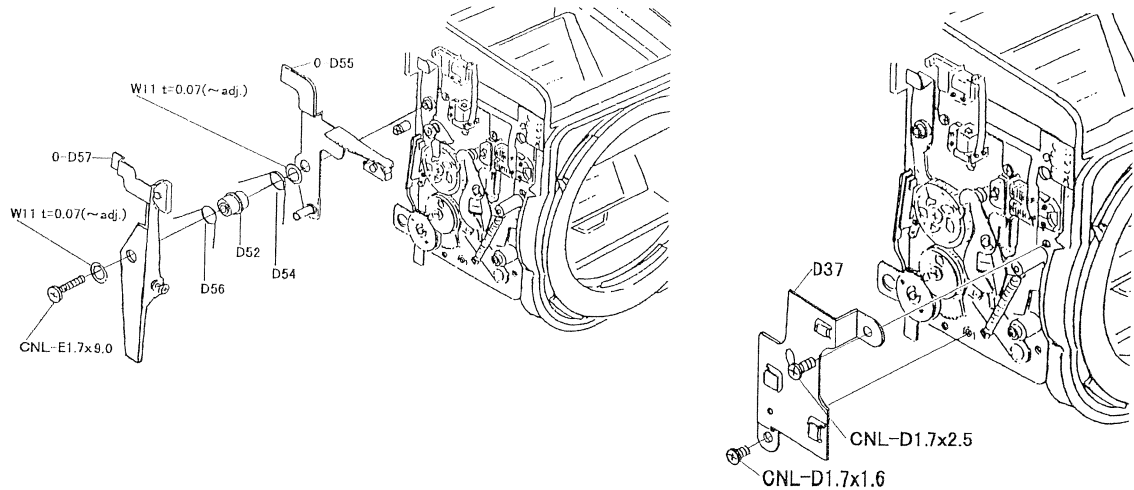

6. Remove CNL-G 1.7 x3.5 x2 and take I230.

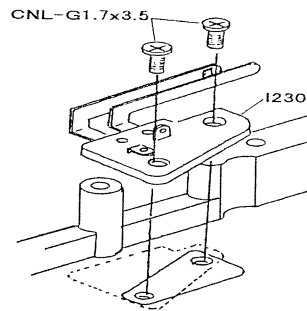

7. Loosen the two screws of E65 (Curtain shaft plate spring) and turn E83 (Curtain checker lever) anticlockwise to release tension.

8. Remove the total of four screws, E93 x2, CNL-D1.7x2.5 and CNS2.0 x2.2, and remove AO-E1 (Damper mechanism assy.).

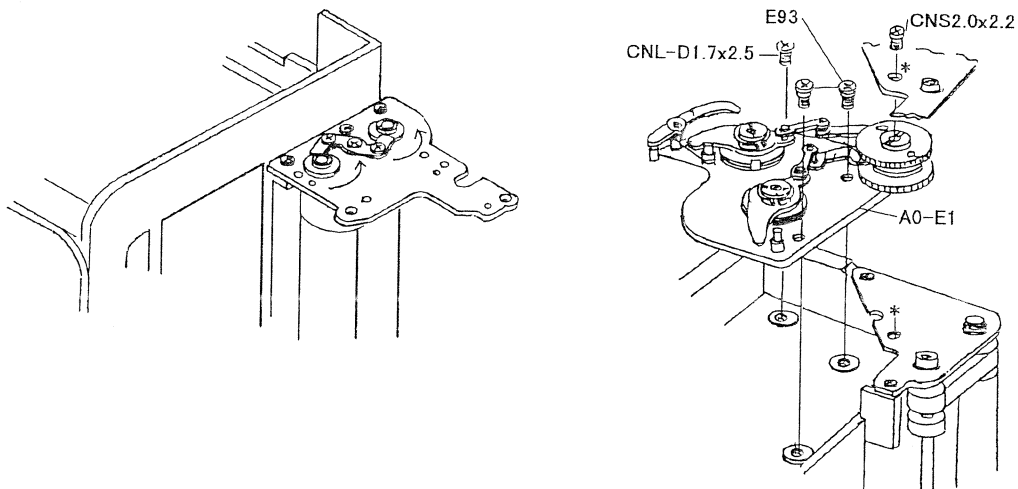

9. Remove in the order E79 (Selector shaft nut), O-E80 (Charge gear), W51 t=0.2 (~adj.), O-E74 (1st selector gear assy.), E78 (Selector shaft collar) and O-E99 (2nd selector gear assy.).

10. Remove in the order E85 (Checker lever retainer screw), E89 (M.E. restrict plate collar), W71 t=0.2 (~adj.), E82 (Curtain checker lever), E84 (Checker lever collar), E86 (Checker lever spring), E82, E84, E86, O-E87 (Mirror stopper release lever), W71 t=0.2.

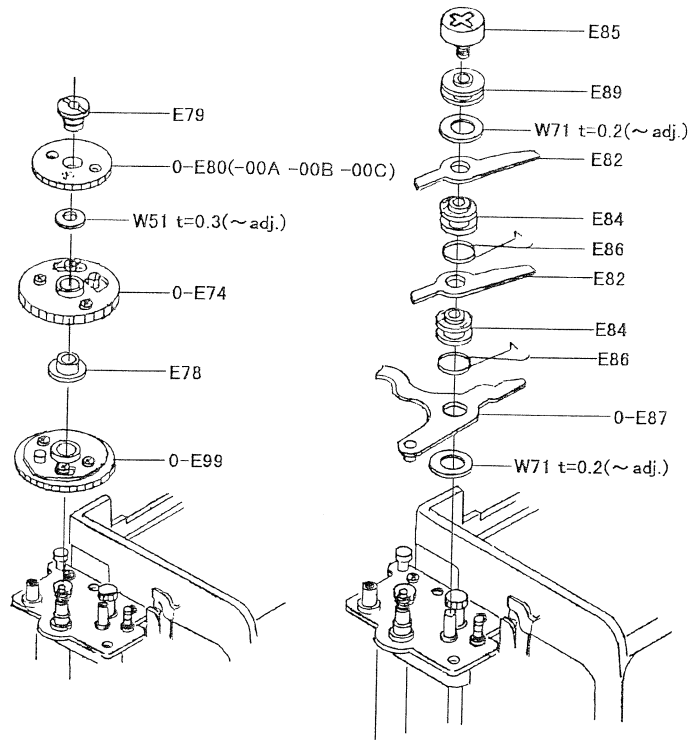

11. A0-E59 (2nd shutter curtain assy.), A0-E63 (1st shutter curtain assy.)

- ① Remove E93 (Shaft plate retainer screw) x2.
- ② Remove E93, CNS1.7 x2.5.

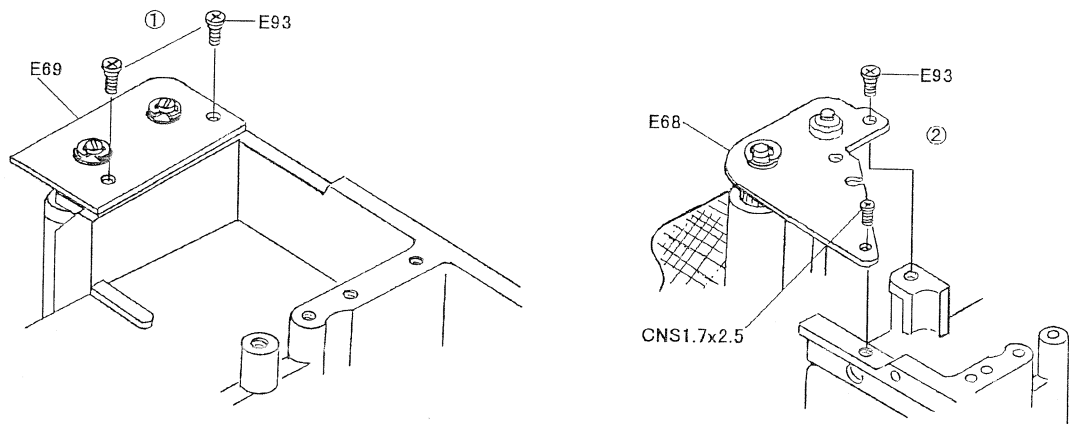

- ③ Remove E93 x2, CNM1.7 x3.0, E110 (Curtain shaft pedestal).
- ④ Remove E93, E97 (Shaft plate A retainer screw), CNS1.7 x4.5.
- ⑤ Remove Shutter curtain block from the Mirror box.

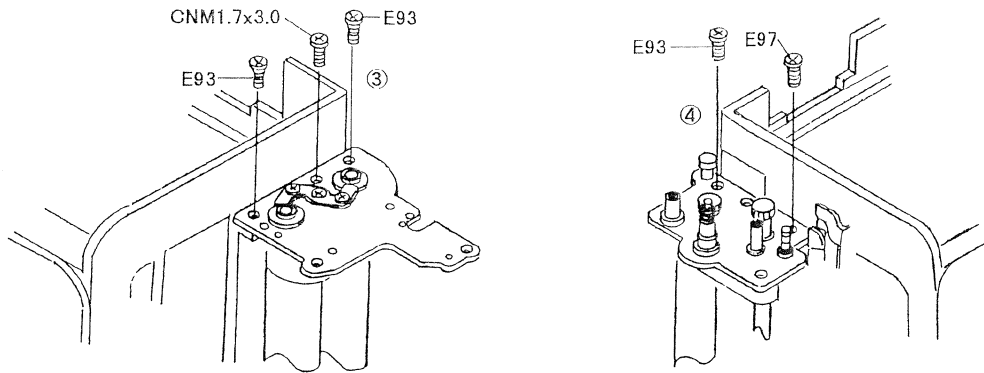

- 12. Remove D23 (Magnet plate retainer screw), CNL-D1.7 x3.0 and take D59 (Magnet plate).

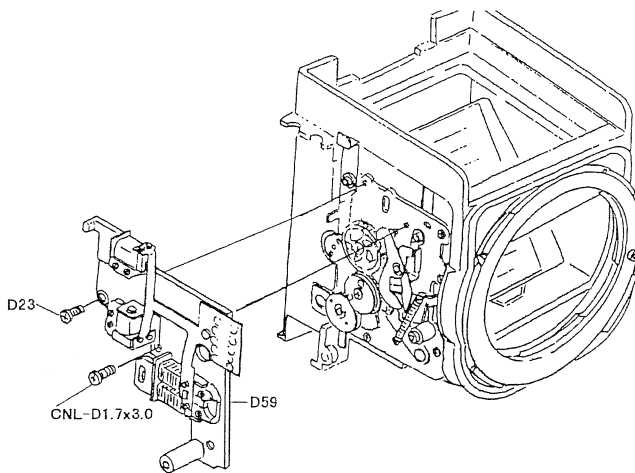

- 13. Remove E93 x2, CNS1.7 x3.0 and detach O-D1 (Mirror base plate) from The Mirror box.

- 14. Peel off B55 (Bayonet seat covering A), B56 (Bayonet seat covering B), B57 (Bayonet seat covering C), B58(Bayonet seat covering D) and take CNS2.3 x5.0 x4, B2 (Mount), W8 t=0.2 (~adj) x4

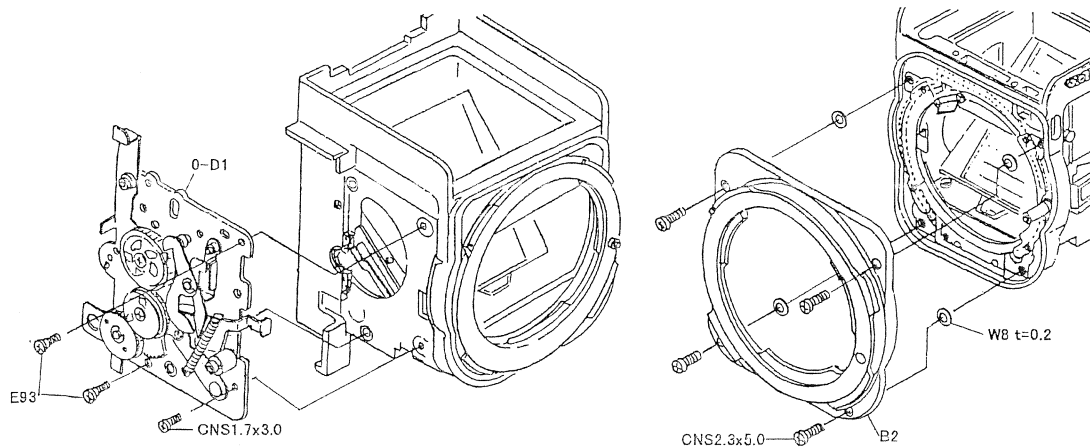

15. Take CNS1.7 x4.0 x4 and remove M3 (Focus screen adjusting plate).
16. Take A33 (Retainer screw C) x2 and remove O-T301 (Viewfinder contact board), M9 (Penta regulation rubber A)x2.

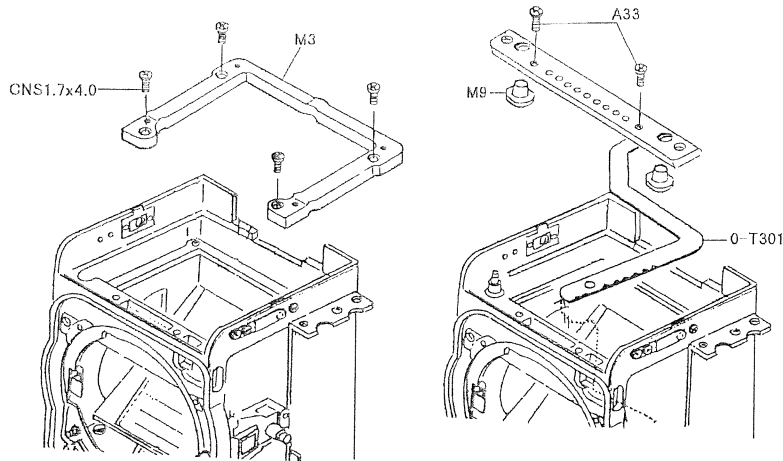

17. [Tool] 95901 K280 (Driver bit 27340-M11)  
Take M11 (Viewfinder positioning pin) x2, and remove M12 (Focus screen retainer spring) x2, M5 (Focus screen retainer) x2.
18. Take CNL-D1.7 x2.5 x4 and free K105 (Slider cover) x2, O-K102 (Diaphragm coupler ring), and remove the catch of K109 (Slider spring).

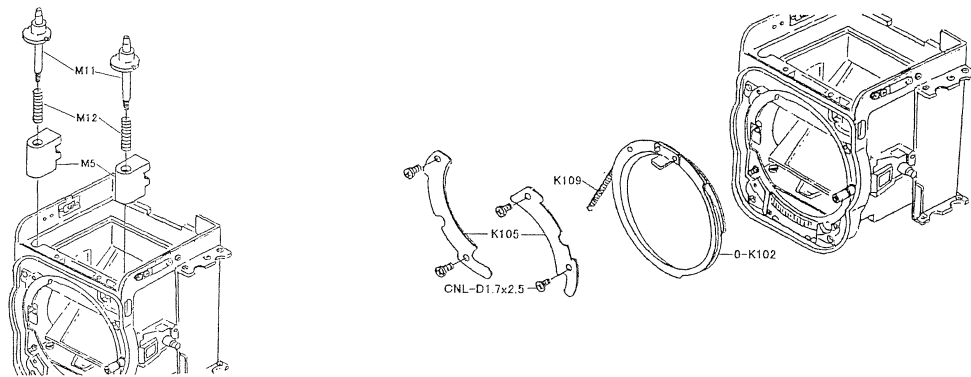

19. Turn the mirror box upside down and remove with the mirror raised in the order D155 (Anti-reflection sheet E) x2, LW13 x4, W2 x4.

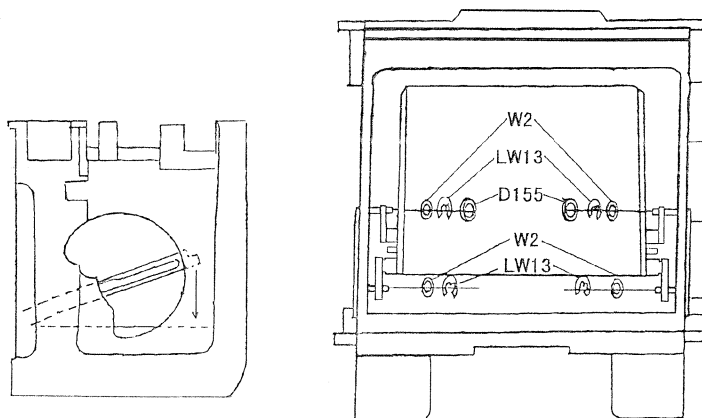

20. Peel off D130 (Light seal tape) x2, remove D147 (Arm pedestal retainer screw) x3, CNL-D1.7 x2.5 (winding side), D147 x2 (Shutter dial side), and remove O-D126 (Arm pedestal) x2 and O-D125 (Mirror sheet) taking care not to mislay the washers.

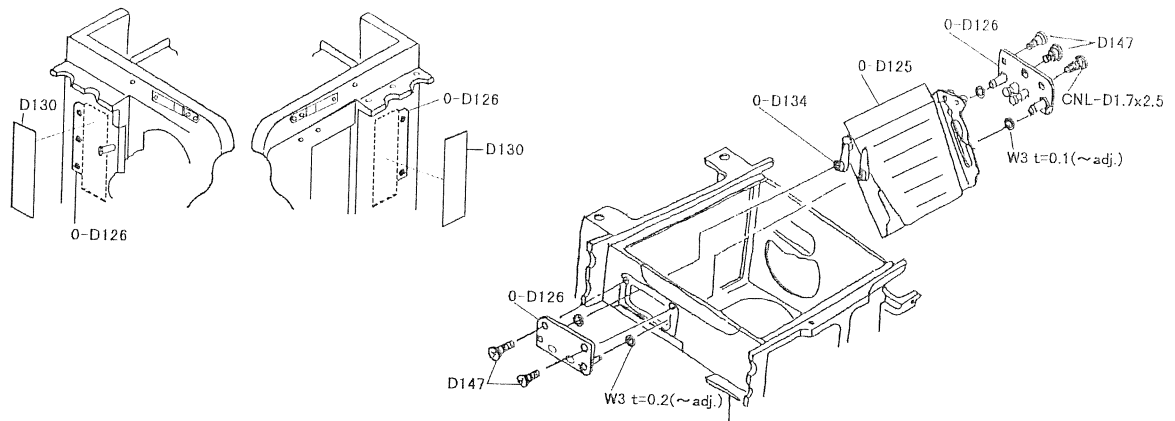

21. Remove D148 (Damper plate adjusting screw) x2 while pressing down D149 (Damper plate adjusting nut) x2, remove CNL-D1.7 x2.0 x2, and take D132 (Damper plate L), and D133 (Damper plate R).

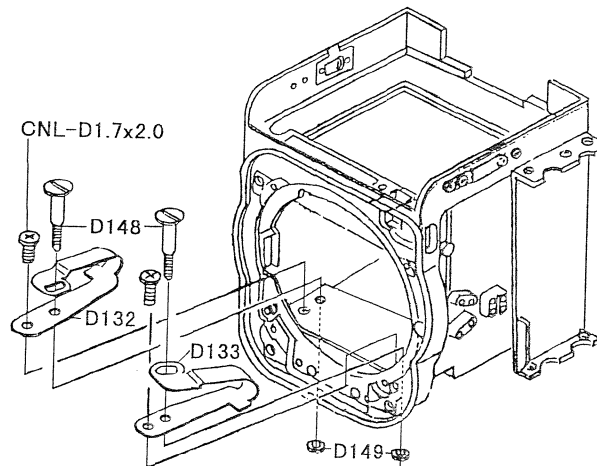

22. Parts not specifically to be removed at the training.:
- B8 (Mirror housing frame),
  - D67 (Mirror stopper support spring),
  - D68 (Support spring retainer collar),
  - D127 (Spring hook screw),
  - K101 (Resistor),
  - K111 (Slider roller),
  - K112 (Slider roller shaft),
  - O-J201 (Light sensor).

## 6. Mirror box assembly

### 6.1 O-J201 (Light sensor assy.)

- 1) Set O-J201 onto the Mirror box and fix with CNL-D 1.7 x3.5 x2.

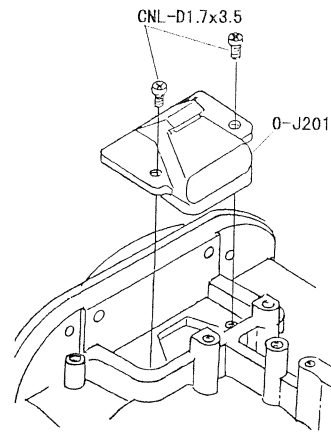

### 6.2 O-B11 (View finder lock plate assy.) x2, O-B14 (Lock release pin assy.) x2

- 1) Set in order of W66 (t=0.2 adj.), O-B11 x2, W3 (t=0.2 adj.) to the Mirror box and fix with TW-CNL-E1.7x1.8 x4.
- 2) Install O-B14 with CNL-D1.7x2.0 x4.
- 3) Check : The Pentaprism should be attached and locked securely.  
Adjust : Changing the thickness of W66.

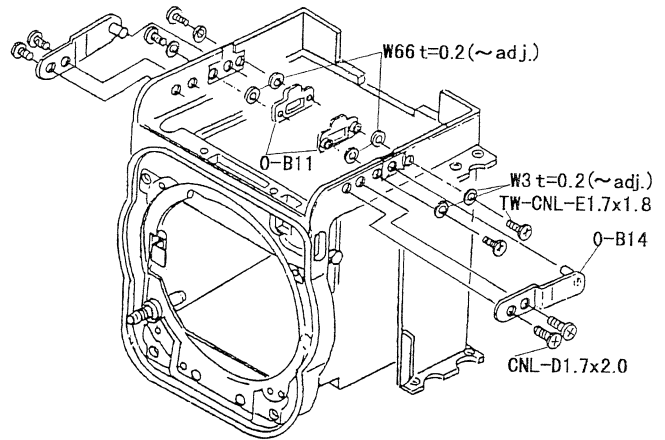

### 6.3 B50 (Light seal cushion),

**B52 (Diaphragm actuator light seal A), B53 (Diaphragm actuator light seal B)**  
**B46 (Mirror sheet cushion)**

- 1) Affix B50 to the Mirror box in the place shown in the drawing.  
Check : There should be no gap at the rounded part.
- 2) Affix B46, B52 and B53 in the place shown in the drawing.

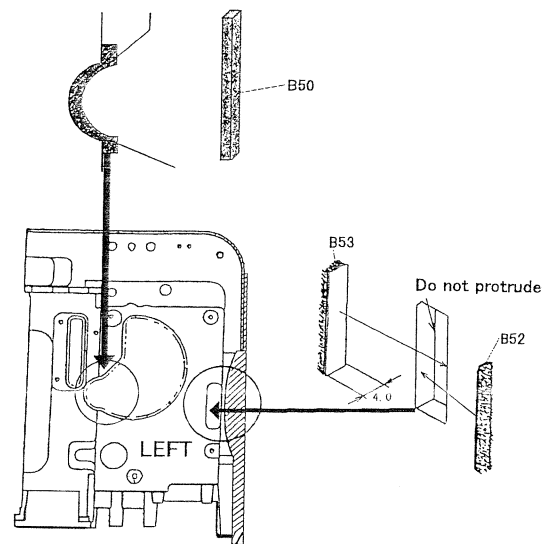
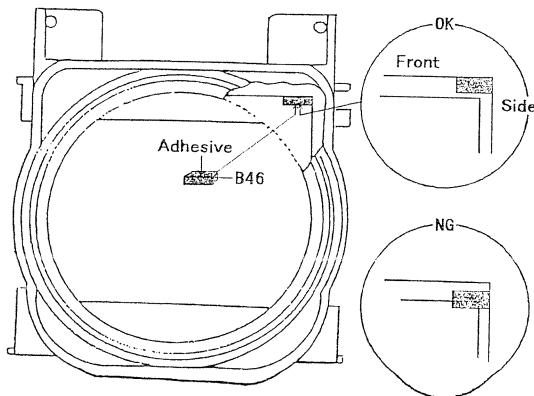

**6.4 D132 (Damper plate L),  
D133 (Damper plate R),  
D148 (Damper plate adjusting screw) x2,  
D149 (Damper plate adjusting nut) x2**

- 1) Install D132 and D133 on the inside of the Mirror box and fix with CNL-D1.7 x2.0.
- 2) Screw in D148 at the temporary position as shown in drawing and fix with D149 temporary.

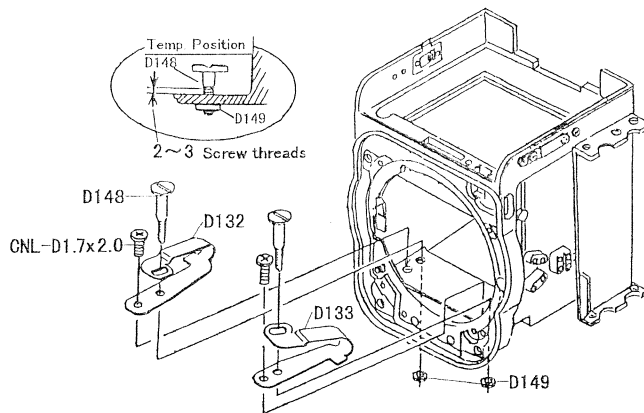

**6.5 Affix L1 (Main mirror)**

Adhesive : CEMEDINE SUPER-X (95901-S114 or S115)  
Refer to [Assembly 9. ] for detail.

**6.6 O-D125 (Mirror sheet), O-D126 (Am pedestal) x2, D147 (Arm pedestal retainer screw) x4**

- 1) Apply black mat paint to the tip and shaft of O-D126.
  - 2) Fit W3 t=0.2 (adj.) into two place on the shaft of O-D126, and apply G31 on shaft.
  - 3) Set O-D134 in a position with the tip facing downwards as in the drawing.
  - 4) Insert O-D125 to the mirror box and set so that the metal section of the arm can be seen from the long holes on both sides.
  - 5) Pass the shaft x2 (Both sides) of O-D126 through the hole of the metal section of the arm of O-D134.
  - 6) Apply Arontite (red) to screw section of D147 and screw down permanently. (2 of driving side)
  - 7) Check : When O-D125 is moved lightly up and down in each direction, it does not chafe against the sides of the mirror box.
- Adjust : Changing the thickness of W3.

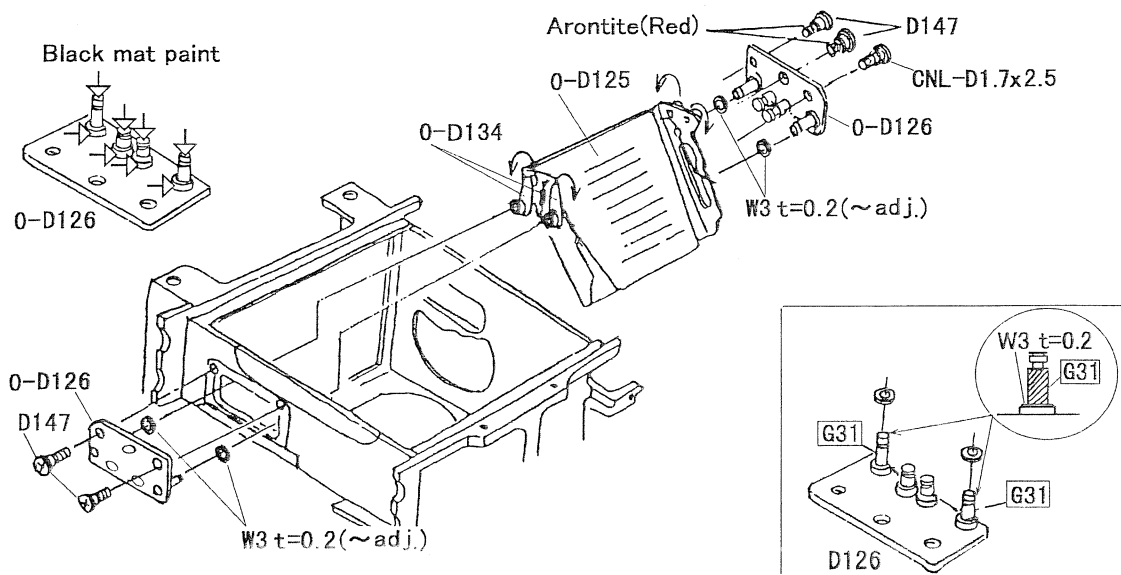



### 6.7 D124 (Mirror arm pedestal spring) x2, D155 (anti-reflection sheet E) x6

- 1) Hook D124 to bottom hook of D126. (Both sides)
- 2) Set up W2 (t= adj., black dye) on shaft of O-D126 x2. 4 places top and bottom, right and left.
- 3) Fix with LW13. 4 places top and bottom, right and left.
- 4) Affix D155 x6 onto LW13.
- 5) Attach D124 x2
- 6) Check : Operation of mirror sheet and horizontal looseness.

① Move lightly horizontally to the extent of looseness of mirror sheet. When moving up and down the mirror sheet should not come into contact with the sides of the mirror box.

② Turn the mirror box upside down. When the mirror sheet has been lifted half way up from the bottom, it should rise fully to the final position under the spring tention of D124.

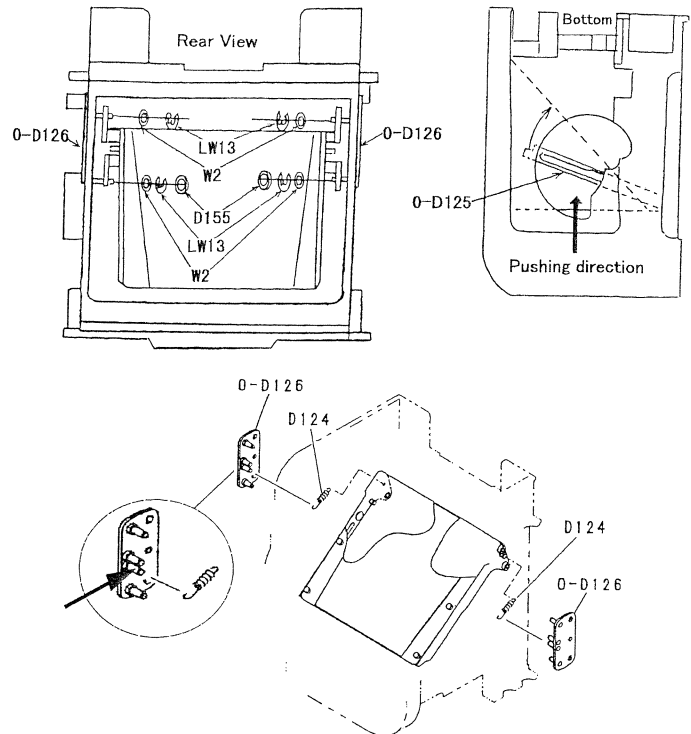

### 6.8 B47 (Light seal curtain)

- 1) Apply Origin Bond to the section ① of the Mirror box and the section ② of O-D125.
- 2) With the rubber surface of B47 on the outside, affix with the central symmetry of the Mirror box, and seal well with fingers.
3. Seal and affix well in the same way in the case of O-D125.

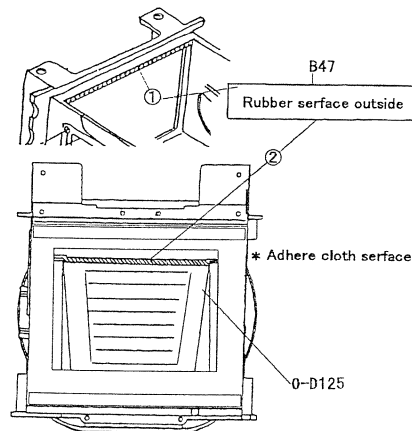

### 6.9 K111 (Slider roller), K112 (Slider roller shaft), K101 (resistor), K117 (resistor insulating tape)

- 1) Install K111-OOB on the Mirror box with K112.  
(K112-00A : Larger diameter, -00B : Smaller, standard uses)
- 2) Insert the lead wires (black, blue, brown) of K101 into hole on front of mirror box and set K101 into the Mirror box with 0.2mm clearance, and fix with K114 x2 from the left side of K101.

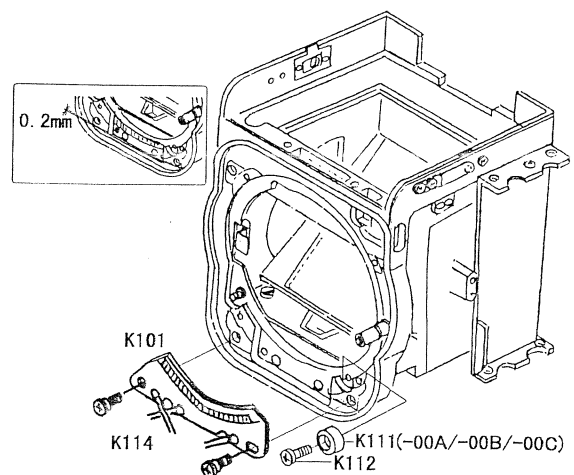

**6.10 O-K102 (Diaphragm couple ring), K105 (Slider cover) x2**

- 1) Wipe K101.
  - 2) Apply L-115 to the O-K102 contact side of the Mirror box.
  - 3) Fit the slider spring (K109) to the slider spring hook (K104) and install K102.
  - 4) Fix K105 x2 with CNL-D 1.7 x2.5 x4.
  - 5) Check : O-K102 should be rotated smoothly.
- Note : Break off the tip of the brush of O-K102 from the V notch when using new parts.

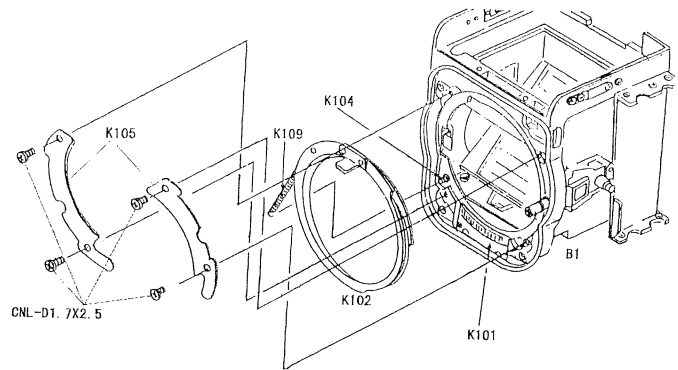

**6.11 M5 (Focus screen retainer) x2,  
M11 (Viewfinder positioning pin) x2,  
M12 (Focus screen retainer spring) x2**

[Tools : 95901-K280 (Driver bit for 27340-M11)]

- 1) Attach to the Mirror box in the order M5, M12, M11 and fix with M11 by the tool.
- 2) Check : Lift up M5, and M5 should be return to the original position by the spring tension.

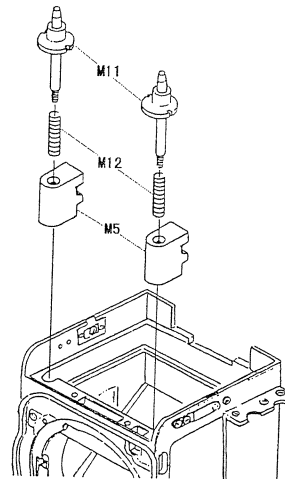

**6.12 O-T301 (Viewfinder contact board),  
M9 (Penta regulation rubber A) x2,  
A33 (Retainer screw C)**

- 1) Pass the flex part of O-T301 through the hole on the Mirror box, and attach M9 x2 onto the Mirror box, and then fix with A33 x2.

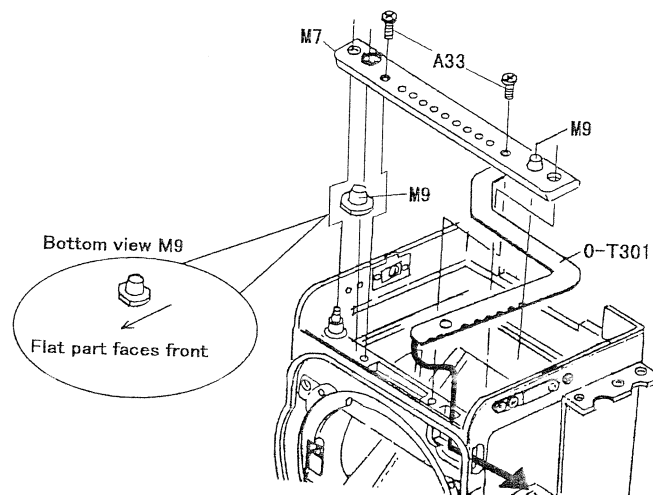

### 6.13 M3 (Focus screen adjusting plate)

#### 1) Installing M3

Insert section ① below M5 and install section ② vertically.

#### 2) Fasten CNS 1.7 x4.0 x4.

#### 3) Fasten the set screws (ST-F 2.0 x2.0 x4) until they contact the die casting surface of the Mirror box.

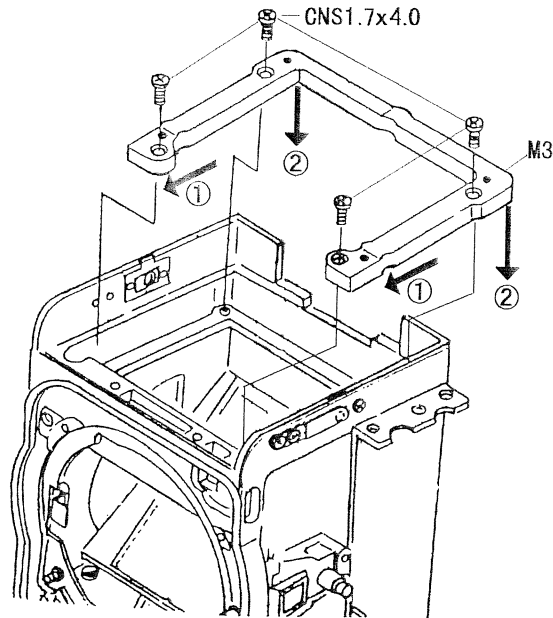

### 6.14 B5 (Light seal spring), K115 (Resistor spacer)

#### 1) Move K115 to the lower side of the Mirror box and attach above 0-K101.

#### 2) Attach B5 to K105 to avoid bumps or gaps between K105 and mirror box as shown in the drawing.

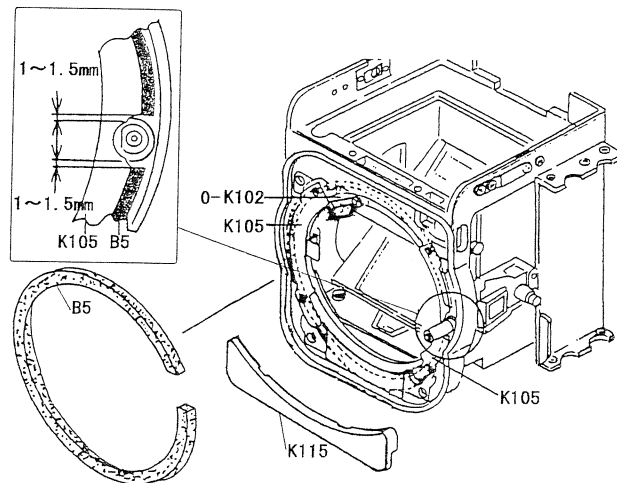

### 6.15 B2 (Bayonet seat) and related parts

#### 1) Align with center of hole of mirror box and set W8 (t=0.2) in four places. (Apply G31 to B3. Refer to next page)

#### 2) Dislodge the slider frame clockwise and fit B2 into the Mirror box.

#### 3) Screw tight with CNS 2.3 x5.0 x4.

#### 4) Check operation of 0-K102.

#### 5) Check operation of B33 (Mount lock lever)

#### 6) Install B55, B56, B57 and B58 (Bayonet seat covering A, B, C, D)

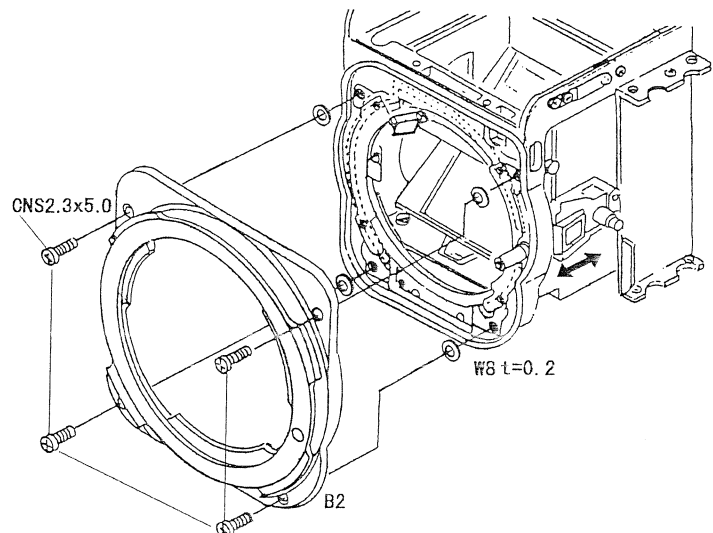

NB : When replacing the Mount, follow the procedures below

B2 (Mount),  
B3 (Mount spring) x3,  
B4 (Mount stopper)

- \* Apply G31 generously to the diagonal line face and end face of B3 x3 as shown in the drawing.
- \* Apply Arontite (red) to the CNS 1.7 x2.2 x8 screw section, and tighten the screws.

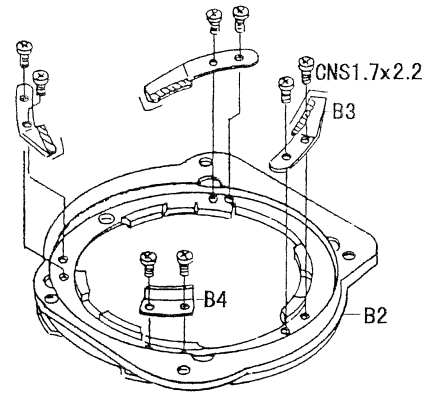

### 6.16 O-D1 (Mirror base plate), E93 (Shaft plate retainer screw)

[ Tool : 95901-N035 (23400-B01-A) Mirror 45 degrees checker

- 1) Apply G31 as shown in Fig. A and Fig. B
- 2) Insert O-D1 into the body.  
While putting the swing lever into the hole of the mirror box, insert the O-D11 section into the long groove of O-D125 and install O-D1.
- 3) Screw tight with E93 x2, CNS 1.7 x3.0.
- 4) Set the Mirror box at the charged state, screw in D148 x2, to create the gap between the mirror seat and the damper plate
- 5) Check : Parallelism of mirror.  
Adjust : Move 0-D126 at the mount lock pin side.
- 6) Tighten 0-D126 installing screw x2, apply Three Bond 1401C to the screw head.
- 7) Check : Mirror 45 degrees check with the Jig.  
Adjust : In/Out of D148 at the driving mech. side.  
When adjustment done, in/out same amount of D148 at the mount lock pin side, and fix with D149.

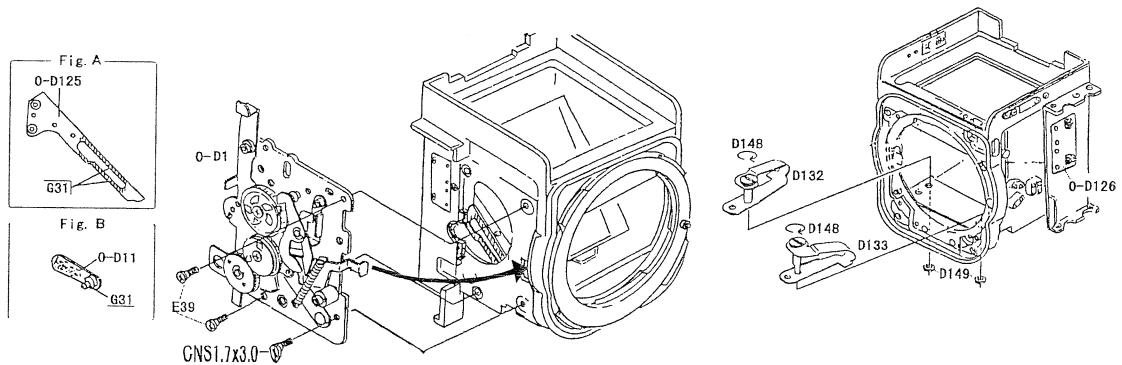

### 6.17 D130 (Light seal tape) x2

1. Affix D130 so as to block the gap between the Mirror box and O-D126.

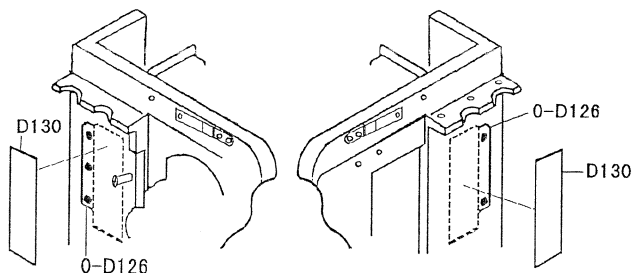

### 6.18 D59 (Magnet plate), D23 (Magnet plate retainer screw)

- 1) Insert D59 into the Mirror box and screw tight with CNL-D 1.7 x2.5 and E93.
- 2) Adjust : Position of S200 (Release MG).

Loosen S200 screws (TY-CNL-B 1.4 x4.0 x2), push down in ← direction shown in drawing, adjust so that the armature shaft comes into contact with the long hole of the armature and comes into the center of the long hole, and tighten TY-CNL-B 1.4 x4.0 x2.

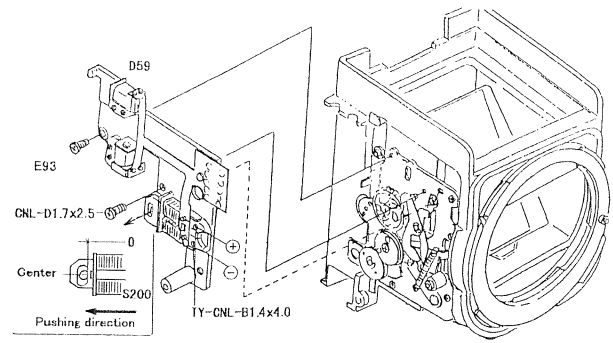

- 3) Charge the mirror and make sure that the stopper does not come loose. The stopper should come off when electricity(1.7V) is apply to magnet.

- 4) Apply Three Bond (1401C) to TY-CNL-B 1.4 x4.0 x2.

### 6.19 D37 (FPC install plate)

- 1) Install D37 on the mirror box and fix with CNL-D 1.7 x1.6 and CNL-D 1.7 x2.5.

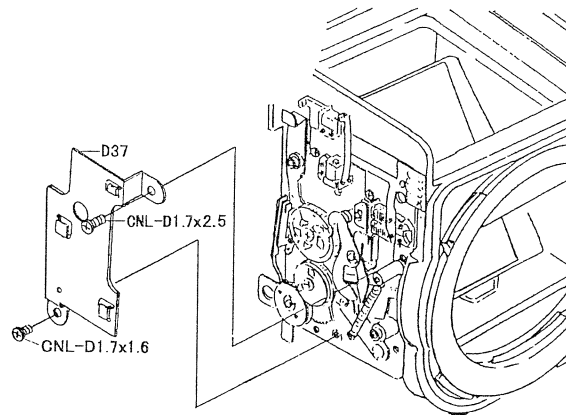

### 6.20 D72 (Wind-end SW fixed contact), D73 (Wind-end SW moving contact)

1. Install D72 and D73 with O-D1 in the charged state and fix with CNL-D1.7 x2.5.

2. At the mirror charged state,

Check : ① Wind-completion SW gap.

**0.5 mm ± 0.1 mm**

: ②The mirror restoring lever should be stopped by contact pressure of D72 and D73.

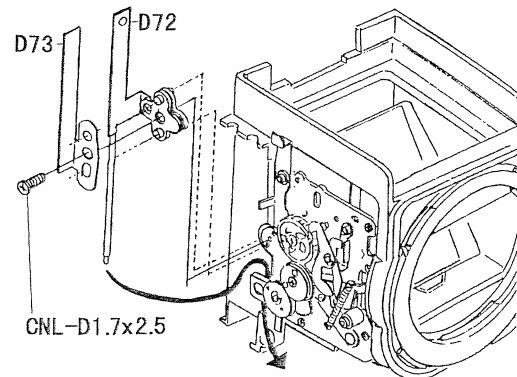
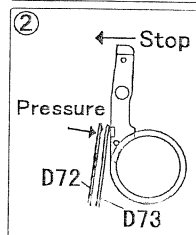
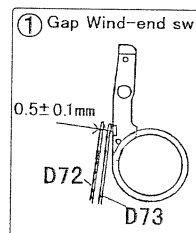

3. Pass lead wire (purple) between O-D1 and the Mirror box.

**6.21 D67 (Mirror stopper support spring),  
D68 (Support spring retainer collar),  
D127 (Spring hook screw)**

- 1) Set D67 and D68 to mirror box and fix with D127.
- 2) Hook the D67 spring.

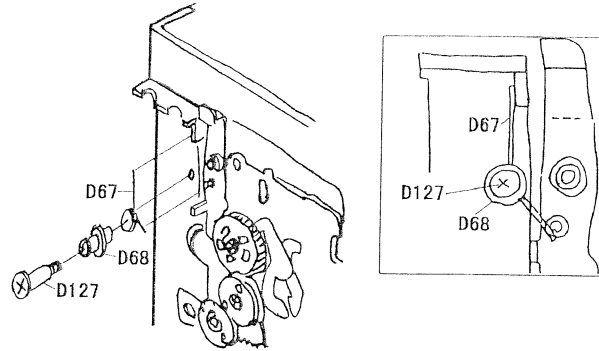

**6.22 D52 (Shutter curtain stopper hook collar),  
D54 (2nd curtain release spring), O-D55 (2nd curtain operation lever),  
D56 (1st curtain release spring), O-D57 (1st curtain lever)**

- 1) Before attaching O-D55 and O-D57, wipe the armature and the core with cleaning liquid.
- 2) Install O-D55, D54 and attach D54 to the dowel section of O-D55.
- 3) Install D52 and D56.
- 4) Install O-D57 to left side of three dowel section of D17. Insert so that upright section of O-D55 and one side of spring D56 fits inside the spring-folded section of O-D57, and fix with CNL-D1.7x9.0.

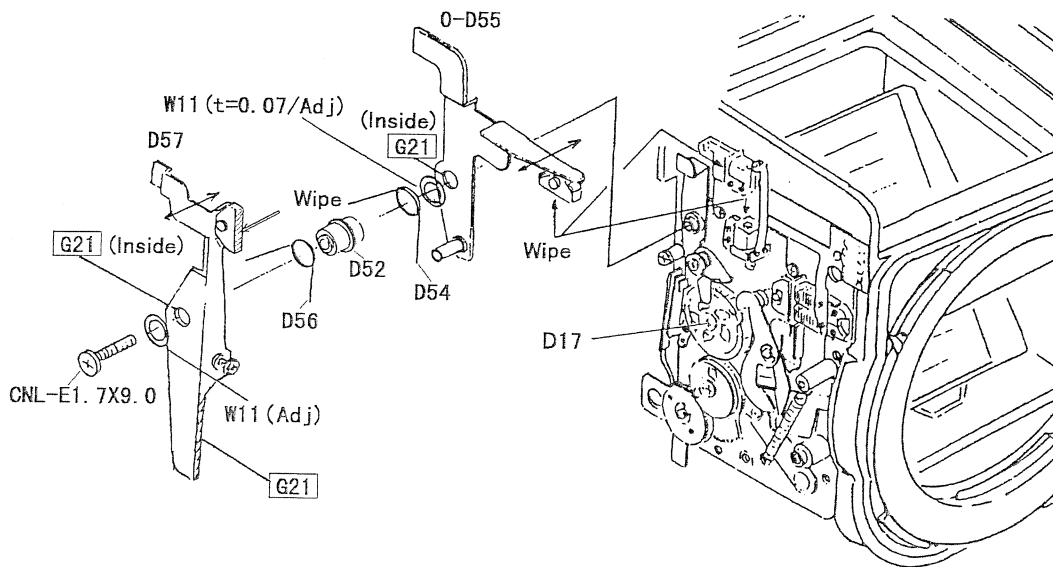

NB: Identification of D54 and D56

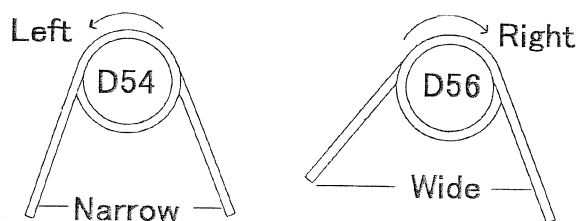

### 6.23 Installation of the 1<sup>st</sup> and 2<sup>nd</sup> shutter curtain (Assembly)

NB: Install the curtains with the mirror box is un-charged state.  
See [ 8. Curtain assembly ] for details on assembly of the curtain.

- 1) O-E67 (Shaft plate A),  
E93 (Shaft plate retainer screw),  
E97 (Shaft plate E retainer screw)

Attach O-E67 section to the mirror box and fix with E93 and E97.

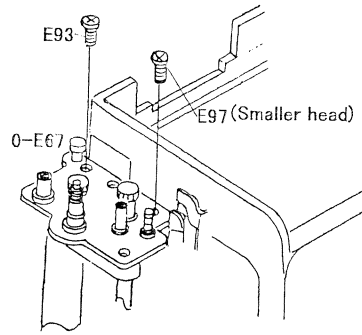

- 2) E110 (Curtain shaft pedestal),  
E93 (Shaft plate retainer screw) x2

Attach E110 to the mirror box and fix with E93 x2 and CNM 1.7 x3.0.

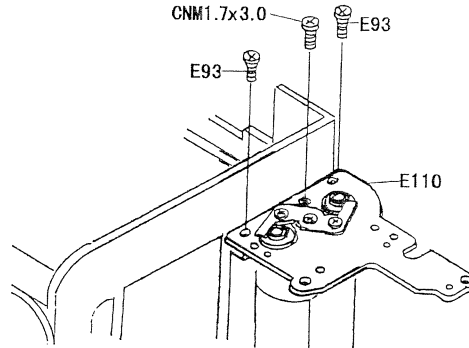

- 3) E68 (Shaft plate B),  
E93 (Shaft plate retainer screw)

Install E68 to the mirror box and fix with E93 and CNS 1.7 x2.5.

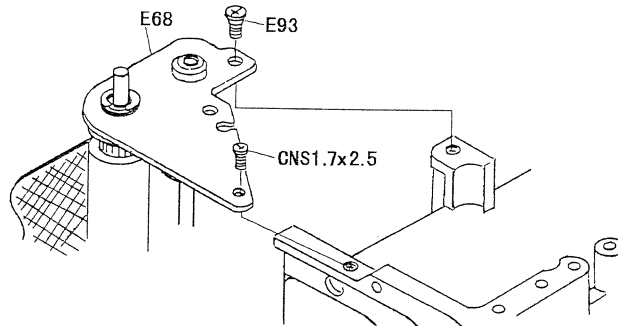

- 4) E69 (Shaft plate C),  
E93 (Shaft plate retainer screw) x2

Install E69 section to the mirror box and fix with E93 x2.

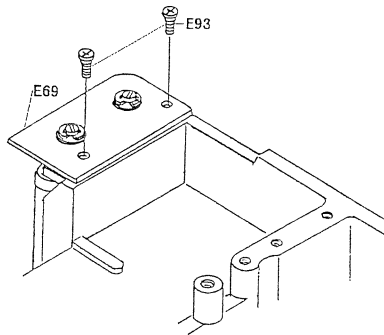

### 6.24 Tension of the curtains

- 1) Loosen CNL-D1.4x2.0 x2 of the curtain installing section, from zero tension of curtains, wind the both curtains 2 to 3 turns clockwise and tighten CNL-D 1.4 x2.0 x2 temporary.

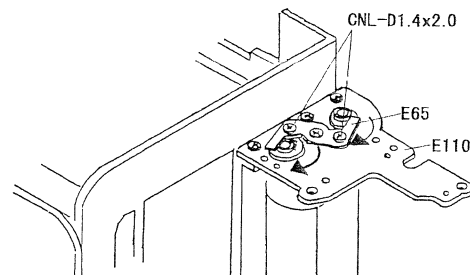

**6.25 O-E87 (Mirror stopper release lever), E86 (Checker lever spring) x2, E84 (Checker lever color) x2, E82 (curtain checker lever) x2, E89 (M.E. restrict plate collar), E85 (Checker lever retainer screw)**

1) Refer to the drawing, install the parts below.

Apply G21 (3 places) to O-E87,  
a drop of L-31 to E84 and  
G21 (2 places) to E82 x2.

Hook E86 (Spring) when installing E82.

Fix with E85.

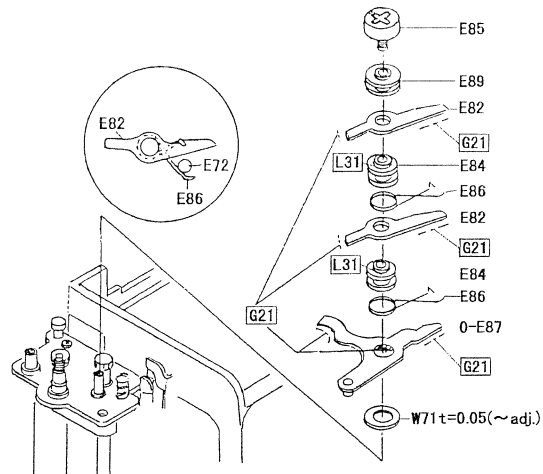

**6.26 [Adjust] Alignment of the curtains**

**O-E74 (1st selector gear assy.), O-E80 (Curtain charge gear assy.),  
O-E99 (2nd selector gear assy.), E78 (Selector shaft collar)**

1) Apply a drop of L-31 to O-E67 (second step of shaft), apply two drops to bore of O-E99, and install temporarily

2) Wind up 2nd curtain with gear E99 and latch. Adjust drive-in of 2nd curtain with eccentric dowel of O-E99. The two curtain drive-in standard lines should be clearly visible. If they are outside the range of adjustment, correct by aligning gear position.

3) After adjustment, fasten two screws of O-E99 and check drive-in position for a second time. Fasten the two screws with Three Bond 1401C. (Screw section and circumference of head)

4) Apply a drop of L-31 to E78 and O-E74, and install in the shaft of O-E67, and then install O-E74 temporarily. The curtain alignment gap should be no greater than 0.1 mm and overlapping no greater than 0.3 mm.

5) Wind up 1st curtain with gear O-E74 and latch. Adjust curtain alignment with eccentric dowel of O-E74.

6) After adjustment, fasten two screws of O-E74 and check curtain alignment for a second time. Apply Three Bond 1401C to two screws.

7) Install in order of W51 t=0.2 (adj.), O-E80.

8) Apply G21 to E79 shaft V groove (collar section) and fasten.

9) After finishing work, slowly run 1st and 2nd curtains and check drive-in amount again.

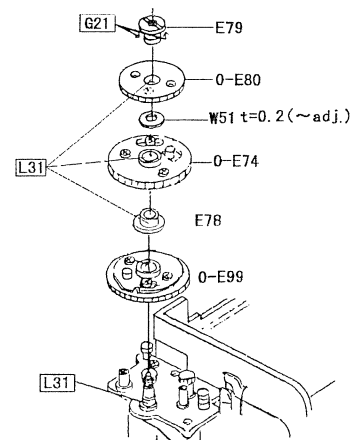
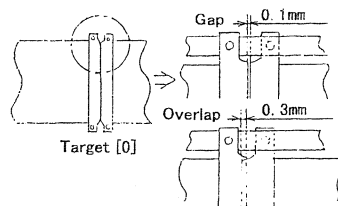
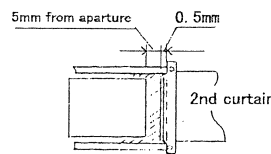



## 6.27 [Adjust] : Installing position of Damper mechanism block(AO-E1)

- 1) Put shutter in wound state.
  - 2) Turn gear ① and ② of AO-E1 to left until they stop, move lever ③ inwards, return 1st curtain gear by 2 or 3 cogs, install in the mirror box, and fix with B93 x2 and CNS 2.0 x2.2.
  - 3) Run the 1st curtain and move cam (a) towards pillar. When this is done, the edge of 1st curtain should come within the mark-off lines.
  - 4) Run the 2nd curtain and move cam (b) towards pillar. When this is done, the edge of 2nd curtain should overlap between 1/3 and 2/3 with the edge of 1st curtain (A).
  - 5) If problems arise with 3 and 4,  
 Wind up the shutter,  
 Remove CNS2.0 x2.2,  
 Slide E68 so that disengage the gears,  
 and change the engagement of gears. (Adjust while moving the lever ③ inward)
- Align 1st curtain with gear ①  
 Align 2nd curtain with gear ②  
 If adjustment is impossible, replace with an appropriate AO-E1.
- 6) After adjustment, wind up shutter curtain and tighten CNL-D 1.7 x2.5.

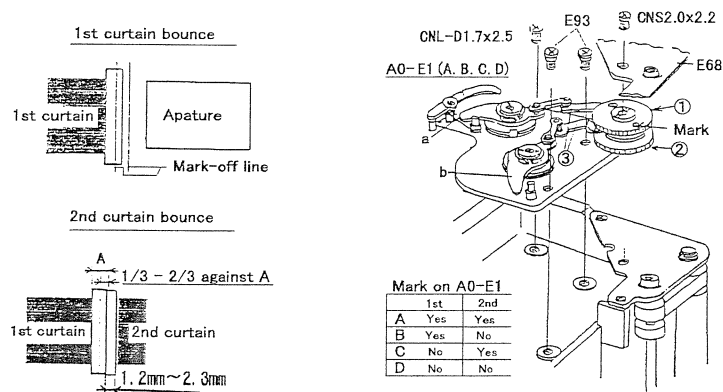

## 6.28 Attachment and adjustment of I230 (X SW)

1. Attach I230 to mirror box with CNL-G 1.7 x3.5 x2.  
 (Attach in wound state. Adjust contact section of I230 as shown in drawing below.)
2. Activate O-E25 in curtain-released state and adjust follow-up quantity of moving contact.  
 (Follow-up quantity: min. 0.4 mm)
3. Adjust extent of gap between moving contact and fixed contact in curtain-wound state. (Gap: 0.15 mm)
4. Wipe X SW. One should be bent and come into contact with head of screw.

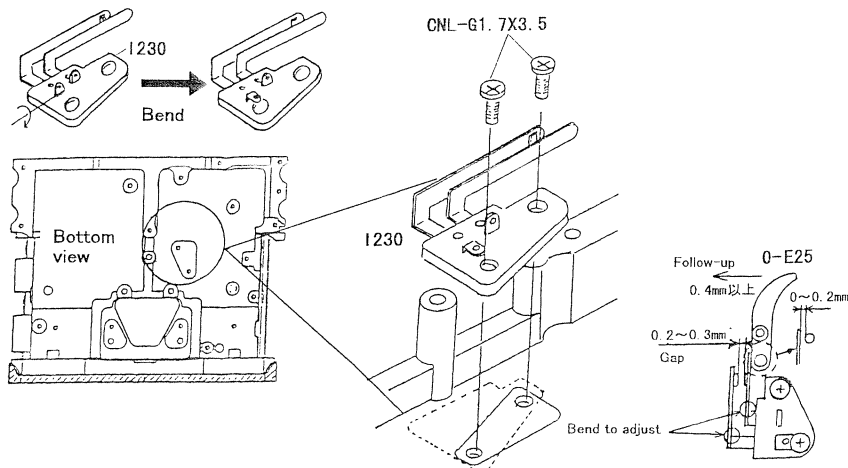

## 6.29 ES magnet adjustment

- 1) Put shutter curtain and mirror base plate (O-D1) in wound up state.
- 2) Loosen 1st curtain Mg installing screw, lightly push down core adsorption surface in parallel on armature adsorption surface and fasten screw. When pushing down the loose part (approx. 0.1 mm) of armature shaft, the gaps on the two shoulders of the armature should be the same.
- 3) Check gap between O-D57 and E82 (1st curtain checker lever). (Gap: 0.5 mm - 1.3 mm)
- 4) Adjust gap between O-D55 and E82 (2nd curtain checker lever) with adjusting screw. (Gap: 0.5 mm - 1.3 mm)
- 5) Apply Alon-alpha 501 (red) to root of adjusting screw and fasten screw.
- 6) Loosen 2nd curtain Mg installing screw, lightly push down core adsorption surface in parallel on armature adsorption surface and fasten screw. When pushing down the loose part (approx. 0.1 mm) of the armature shaft, the gaps on the two shoulders of the armature should be the same.
- 7) Check :
  - ① Apply the voltage (1.7V) to the magnet so that it adsorbs.
  - ② Set the wind up state, release the stopper of the mirror and rise-up the mirror.
  - ③ Push O-D57 lightly, and let it go slowly. The 1st curtain should be run.
  - ④ Push O-D55 lightly, and let it go slowly. The 2nd curtain should be run, and mirror should go down.
- 8) After completing adjustment, apply Three Bond 1401C to 1st and 2nd MG and installing screws x4.

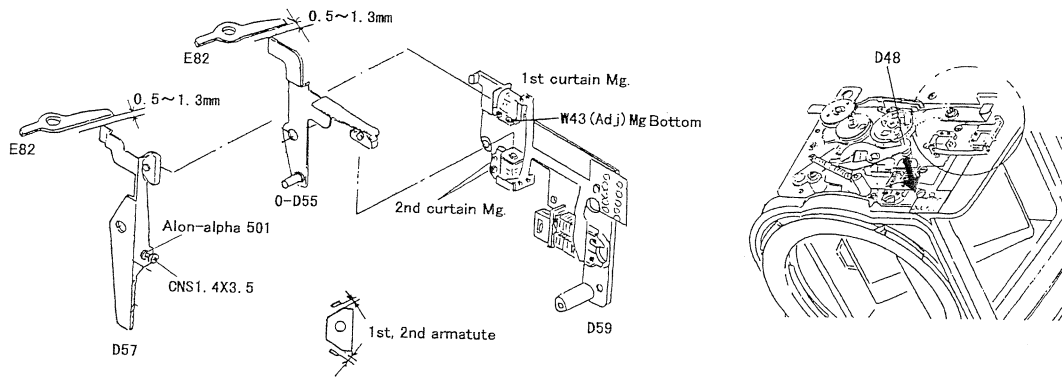

## 6.30 Checking operation of mirror box block

[ Jigs and tools ] : Regulated voltage power source.

- 1) Wind up shutter curtain and mirror box.
- 2) Solder lead wires to illustrated places on T331 (shutter magnet relay P.C. board).
- 3) Check :
  - Mirror-up occurs after feeding to ①
  - 1st curtain runs after power flow is cut to ②
  - 2nd curtain runs after power flow is cut to ③
- 4) Check ①, ② and ③ again with mirror box placed in reverse position.  
(Take care to avoid short-circuiting.)

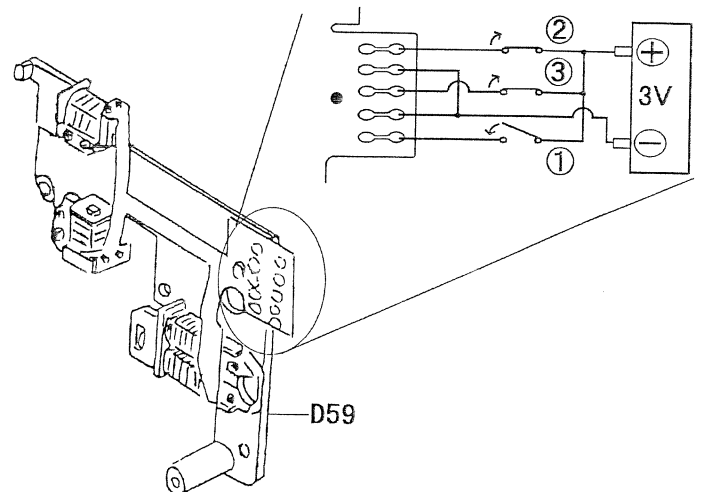

### 6.31 O-D55 (2nd curtain operation lever assy.), O-D57 (1st curtain lever assy.), silicon application

Silicon : 95901 S141 (Toshiba TSE397)

1) At the mirror and shutter are in wound state, apply 3V current to ②, ③ of the drawing on front page (6.30).

2) Unhook D48 and put mirror up.

3) Apply silicon to 4 places on armature parts of O-D55 and O-D57.

4) Leave undisturbed for 12 hours with current on and mirror up. Place O-D1 faces upwards. Silicon should not attach to any other places.

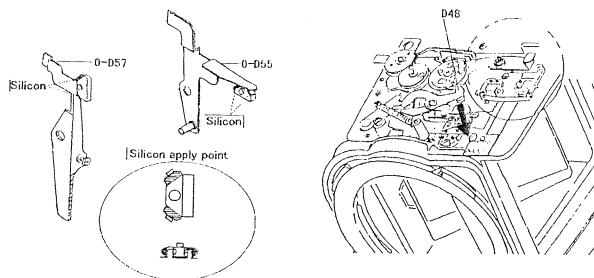

### 6.32 Installation of T100 (Main P. C. board)

#### 6.32.1 T100 (Main P. C. board), T3 (FPC retainer screw), T13 (Tape C), DT 5x6

- 1) Bend T100 and insert into mirror box.
- 2) Fasten in the order T3, CNL-D 1.7 x2.5 x3.
- 3) Affix DT (5x6) to the mirror box.  
Affix AM switch land in alignment with guide using DT (5x6).
- 4) Insert flex of T100 on O-D1 side into D37.
- 5) Insert flex of T100 on rear side of S100 (2nd curtain release Mg) of D59 (magnet block).
- 6) Insert flex of T100 into the stud of D59, affix M-UP round reverse side of T100 flex with T13.
- 7) Solder 5 lands

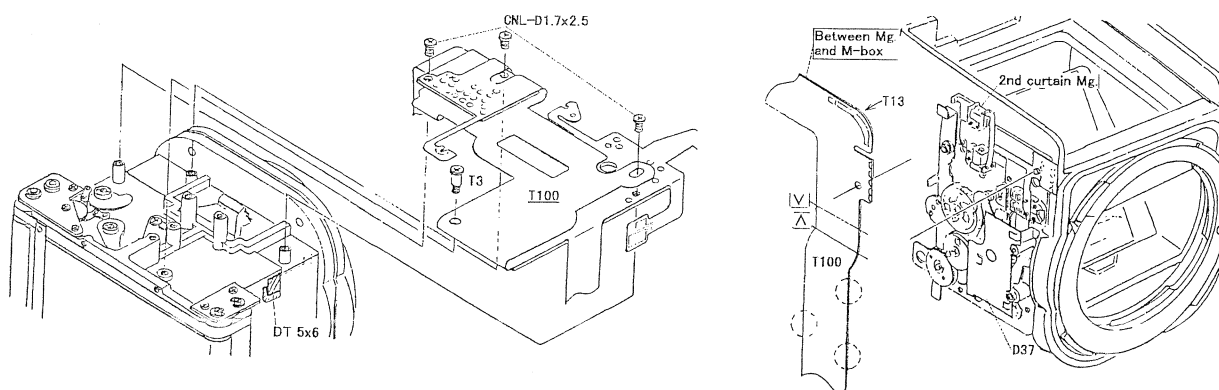

### 6.32.2 B21 (Focus screen SW contact), B22 (Focus screen SW pin) x2

- 1) Bend T100 along fold from bottom surface of mirror box and install in side.
- 2) Wipe T100 lands and B21 contact with cleaning liquid.
- 3) Insert B22 x2 into body, mount B21 and fasten with CNL-D 1.7 x2.0 x2.
- 4) B21 should be off when B22 x2 is pushed from inside body.
- 5) Combine T301 flex with T100 and fasten with CNL-D 1.7 x2.0.
- 6) Solder 9 lands. (T00 – 0-T301)

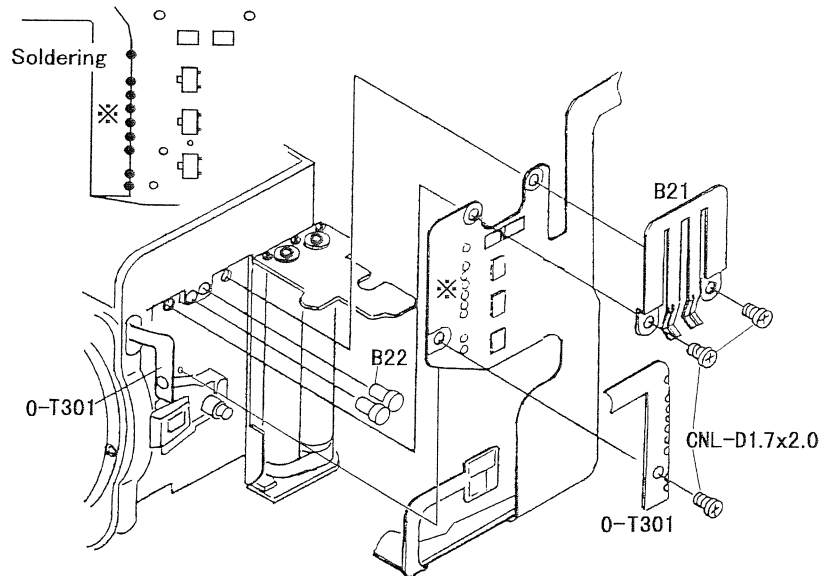

### 6.32.3 O-B36 (Lock-pin guide assy.), B41 (AM SW collar), B42 (AM SW), B43 (AM SW spring)

- 1) Insert 0-B36 (included B39) into the mirror box and fasten with CNL-D 1.7 x3.5.
- 2) Check the function of the Mount lock lever.
- 3) Wipe AM SW land of T100 and B42 contact, and install B42 and B41 into mirror box and fasten with CNL-D 1.7 x4.5.
- 4) Install B43 and attach spring to B42 and mirror box.

NB : Bend contact of B42 from V notch and remove. (When using new items)

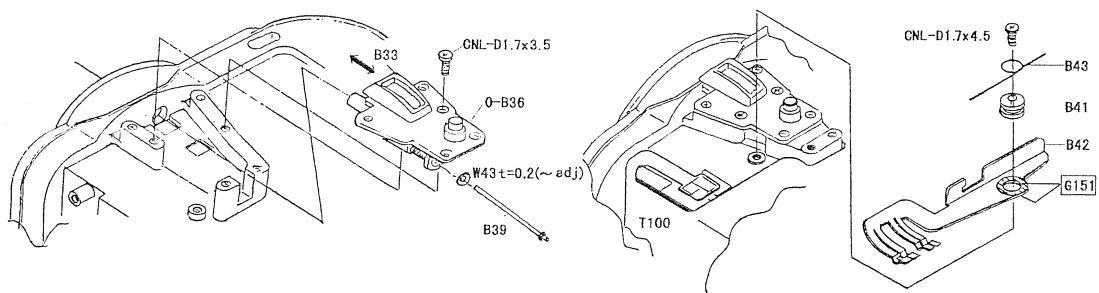

### 6.32.4 O-E91 (Duality prevention lever assy.), E95 (Duality prevention lever spring), T100 (S300 part)

- 1) Install E95, O-E91 on shaft of O-E67 and fasten with CNL-F 1.4 x2.5.
- 2) Attach E95 spring to E96 and O-E91 as shown in drawing.
- 3) Apply G-21 all round O-E67.
- 4) Insert tip of I-E91 into armature part of S300 and fasten S300 part of T100 to mirror box with CNL-D 1.7 x3.5.

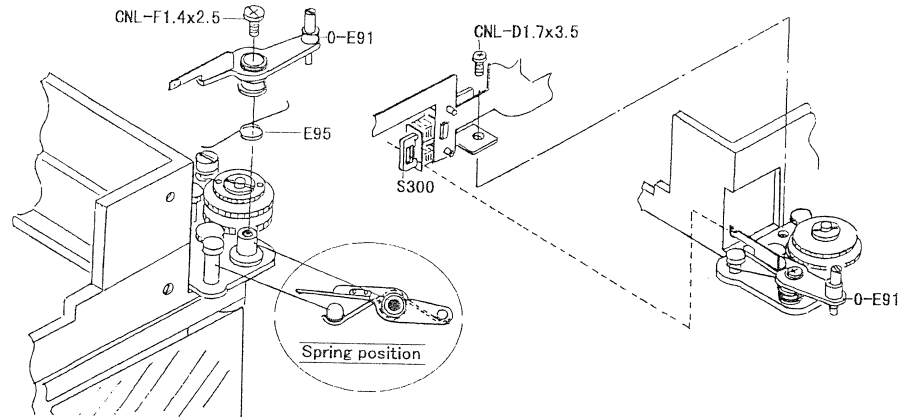

### 6.32.5 T100 (T301 part), O-J201 (Light sensor) soldering

- 1) Solder lead wires to T100 from K101.  
Black, Blue, Brown
- 2) Solder O-J201 (Light sensor) and T100 flex.  
2 soldering lands
- 3) Solder I230 (X contact) and T100 flex.  
a soldering land
- 4) Treat lead wires (black, brown, blue) under T100 flex.

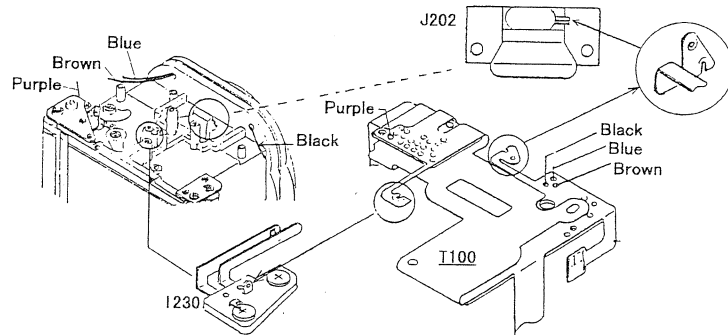

### 6.33 Check : Shutter curtain operation

[ Tools ] 95901-K165 (23400K-E80-A)

NB: Owing to large diameter of head of E79 (Selector shaft nut), inside of 23400K-E80-A should be shaved with a file.

- 1) Check alignment and parallelism of curtains.  
Standard :  
Curtain alignment : gap max. 0.1 mm  
Overlapping : max. 0.3mm,  
Slant: max. 0.3 mm
- 2) 2nd curtain drive-in amount  
Standard :  
On the inside mark-in line to two mark-in line.

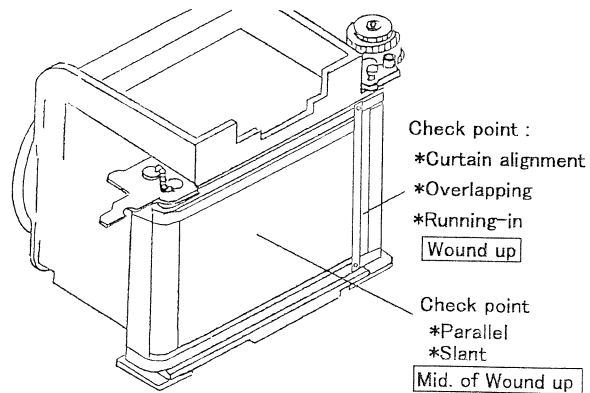

## 7. O-D1 (mirror base plate) assembly

### 7.1 O-D11 (Mirror actuator arm), O-D14 (Center gear assy.), D17 (Mirror operation plate), etc.

[Adhesive] : 95901 S120 (Arontite red 50cc)

- 1) Apply G21 to outer circumference of cam of O-D14, bore of O-D14, and shaft section of O-D11.
- 2) Install O-D14 into O-D1 shaft, turn to right, and bring up against stopper.
- 3) Attach hook of D17 to D19, turn to right by  $180 \pm 30$  degrees, latch D17 at place marked with an asterisk, and install above O-D14.  
Note: Use a black marker pen at D19 hook position of O-D14 to facilitate assembly.
- 4) Align hook section of O-D11 with protruding part side (45 degrees to lower left) of O-D1, attach in alignment with square hole of D17, apply Arontite (red) to screw section of CNL-G2.0 x3.5, and fasten.

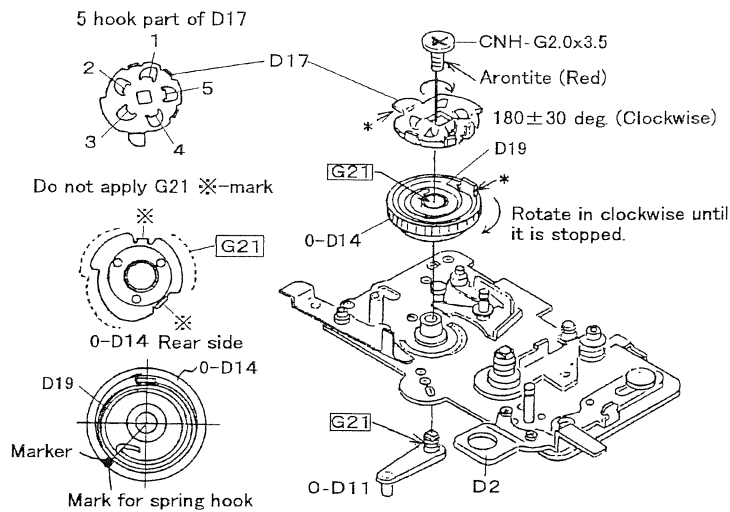

### 7.2 D24 (Restoring gear), D26 (Mirror restoring spiral spring shaft), D31 (Swing lever spring), O-D32 (Diaphragm charge gear), etc.

- 1) Apply G21 to bore of O-D32 and three places each on upper and lower protrusions (convex).
- 2) Insert O-D32 into pillar of O-D1 and align pin of O-D32 with O-D1 lever hole.
- 3) Apply G21 to bore section of D24 and insert D24 into O-D1 pillar as in drawing so that outer circumference side of D27 spring hook comes in a position within 40 degrees from standard.
- 4) Attach hook A or B of D26 to hook on bore of D27 spiral spring, turn anti-clockwise by  $135 \pm 20$  degrees, and install D26 in O-D1 square shaft.
- 5) Apply G21 to two places on bore of D31 hook part and latch on to upright parts of each as shown in drawing.

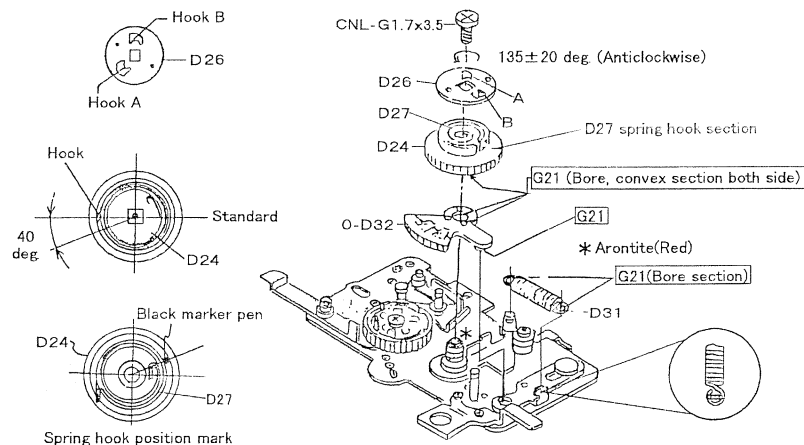

**7.3 D44 (Release spring), D48 (Mirror stopper hook), D49 (Diaphragm stopper hook collar), D50 (Diaphragm stopper hook), D58 (Joint spring), etc.**

- 1) Apply G21 to bore of D48 and D50 and to dotted line section as shown in drawing.
- 2) Attach D44 to pillar of O-D1 as shown in drawing and attach spring.
- 3) Insert D50, W9 t=0.05 (~adj.), D49, D58 to pillar of O-D1, and fasten with LW13.  
Vertical looseness of D48 and D50 should be less than 0.05 mm. Operation should occur smoothly.
- 5) Attach D58 spring to D50 and D48 respectively.  
Catch of D48 and D17 stoppers should be more than half the plate thickness.

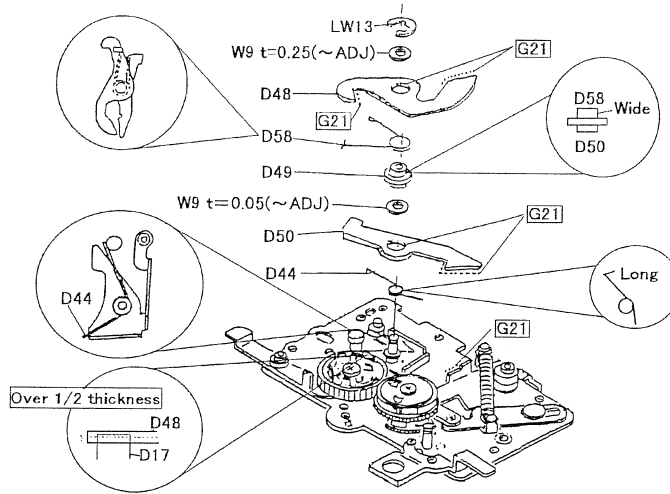

**7.4 D6 (Ball receptacle washer A), O-D40 (Mirror charge double gear), O-D43 (Mirror charge interval gear C), etc.**

- 1) Apply G21 to outer circumference of pillar of O-D1, and attach by aligning position of pin of O-D40 with gear held down clockwise as shown in drawing.
- 2) Rotate O-D40 slightly anticlockwise, slowly return O-D40 in a state with D48 and D50 stoppers removed, whereupon D48 and D50 should be firmly latched.
- 3) In the event that D48 and D50 are not firmly latched following check carried out in item 2 above, move attachment position of O-D40 vertically and look for position in which D48 and D50 catch firmly.
- 4) Apply G21 to bore of O-D43, attach D6 and fasten with LW15.
- 5) Check gap between O-D1 lever and D50 in pre-wind state. (0.6 - 0.9 mm)

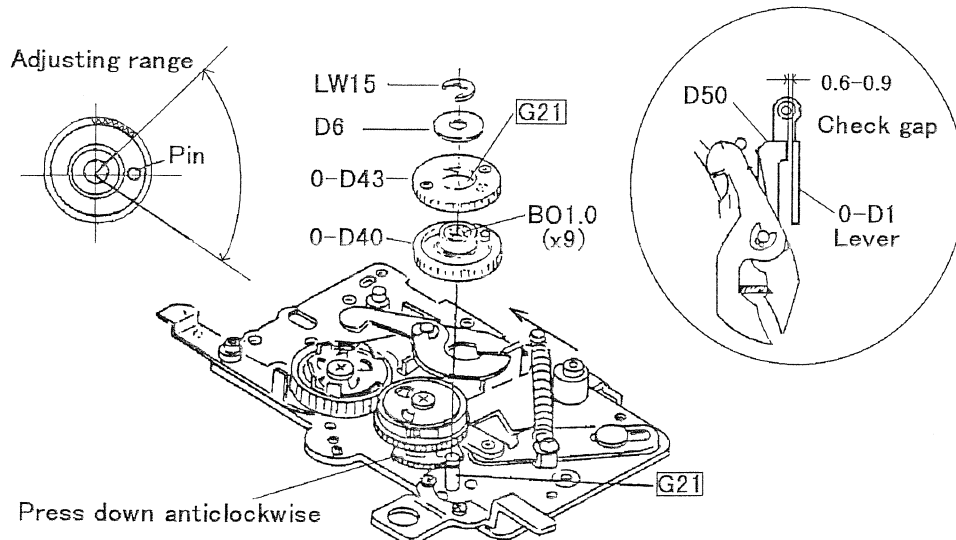

### 7.5 O-D1 (Mirror base plate assy.) operational check

- 1) D48, D50 vertical looseness ----- max. 0.05
- 2) D48, D17 latching ----- max. 1/2 of plate thickness of D48
- 3) Mirror restoration lever operation -- Should operate smoothly.
- 4) Position of O-D40 gear ----- Slightly wind O-D43 anticlockwise, loosen catch, slowly return O-D43, hereupon catching should occur.
- 5) Winding of O-D43 ----- There should be no winding stiffness or hang-up.  
If the stopper is removed, readjust O-D40.
- 6) Position of D24 hook ----- Should not come into contact with D43 during winding.
- 7) Position of D17 hook ----- Check in black marker pen position and spiral spring stop position after winding.
- 8) Position of D26 hook ----- Check in black marker pen position and spiral spring stop position after winding.
- 9) D50 gap ----- 0.6 - 0.9 mm

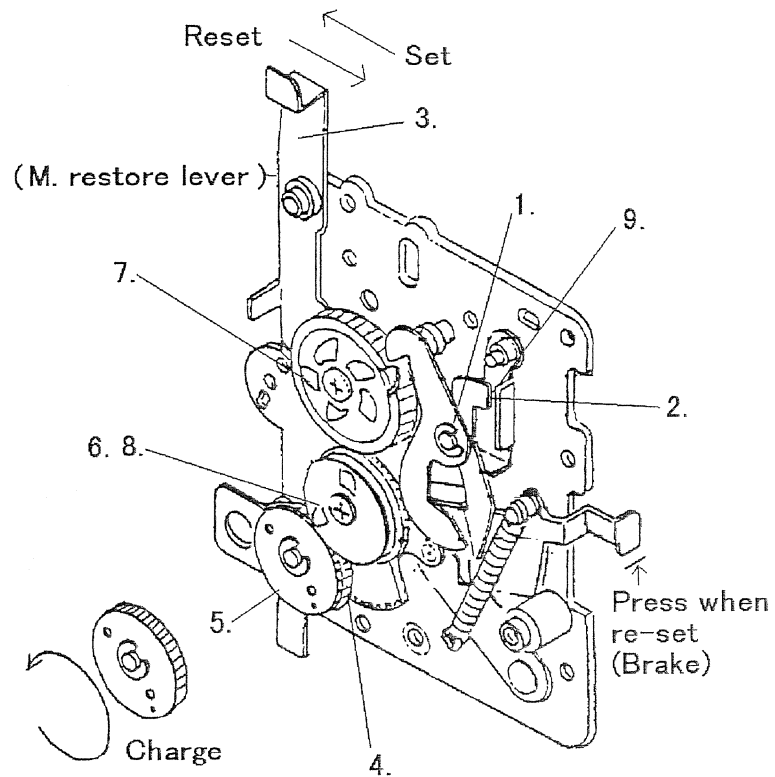



## 8. Assembling curtains

(Following explanation is concerned with assembly of the shutter curtain block.)

### 8.1 E53 (Curtain adhesive tape) x2, E54 (Ribbon adhesive tape) x2, O-E59 (2nd shutter curtain), O-E63 (2nd shutter curtain)

- 1) With fabric surface of O-E59 and O-E63 upwards, mount in alignment with E54 in two places at both ends of ribbon.
- 2) Apply solvent from above ribbon, lightly press from above ribbon and adhere with E54.
- 3) With adhesive surface of E53 downwards, create a gap of 0.2 - 0.5 mm on rubber surface of O-E59 and O-E63 and combine.
- 4) Apply solvent evenly over one third from above E53 (gap between tip surfaces 0.2 - 0.5 mm), and lightly press.
- 5) Apply solvent evenly on E53 from gap on un-bonded part, and lightly press.
- 6) After bonding E53, apply solvent evenly from four directions (vertical and horizontal) from above backing paper of E53.
- 7) Get rid of any protrusions of the adhesive.
- 8) Leave affixed section of E54 for more than 4 hours.  
The affixed section of E53 should be left undisturbed for more than 12 hours.

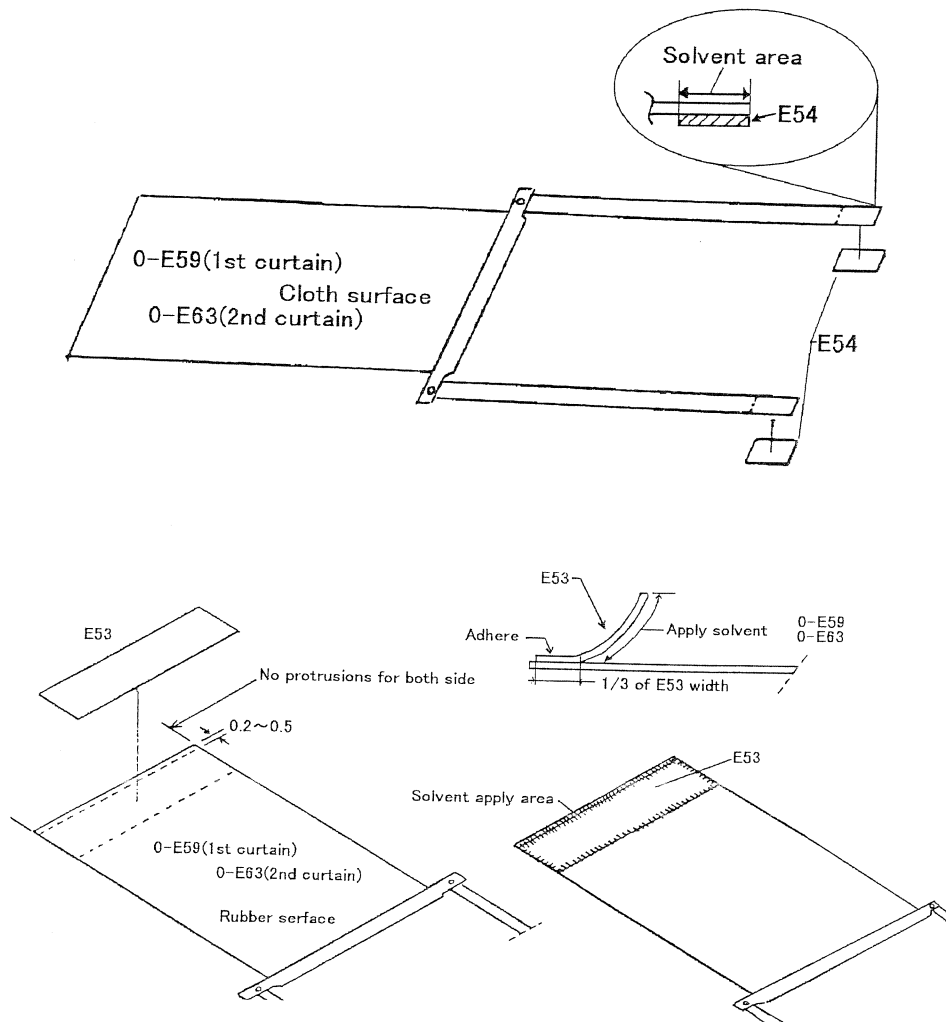

8.2 O-E41 (Curtain pipe), O-E42 (1st curtain pipe), O-E43 (2nd curtain pipe),  
E48 (1st curtain shaft A), O-E49 (1st curtain shaft B), etc.

- 1) Remove any oil from ribbon attachment section of O-E43.
- 2) Peel off backing paper E54 on O-E59 and attach ribbons with low place on drum ramp section of O-E43 as standard.
- 3) Rotate O-E43, wind off ribbon, and seal.
- 4) Provisionally attach E48 and O-E49 to O-E35 and remove any oil from E48 attachment section and O-E49 attachment section.
- 5) Peel off backing paper E54 on O-E63 side and attach ribbons with low place on drum ramp section of O-E49 as standard.
- 6) Rotate O-E35, wind off ribbon, and seal.
- 7) Remove any protruding adhesive, etc., and leave undisturbed for more than 12 hours.

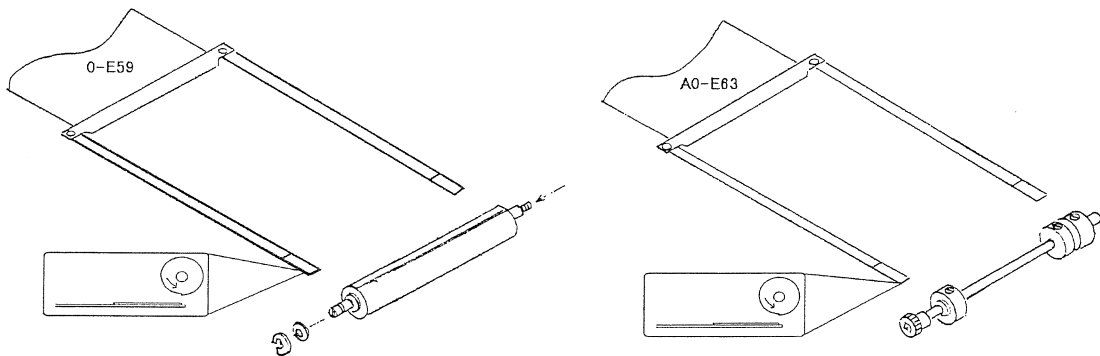

- 8) Remove any oil from O-E41 ribbon attachment section.
- 9) Remove peeling paper E53 on O-E59 side and attach shutter with a low place on drum ramp section of O-E41 as standard.
- 10) Rotate O-E41, wind shutter and seal.
- 11) Remove peeling paper E53 on O-E63 side and attach shutter in principle with low place on ramp section of O-E42 as standard.
- 12) Rotate O-E42, wind off ribbon, and seal.
- 13) Remove any protruding adhesive, etc., and leave undisturbed for more than 12 hours.

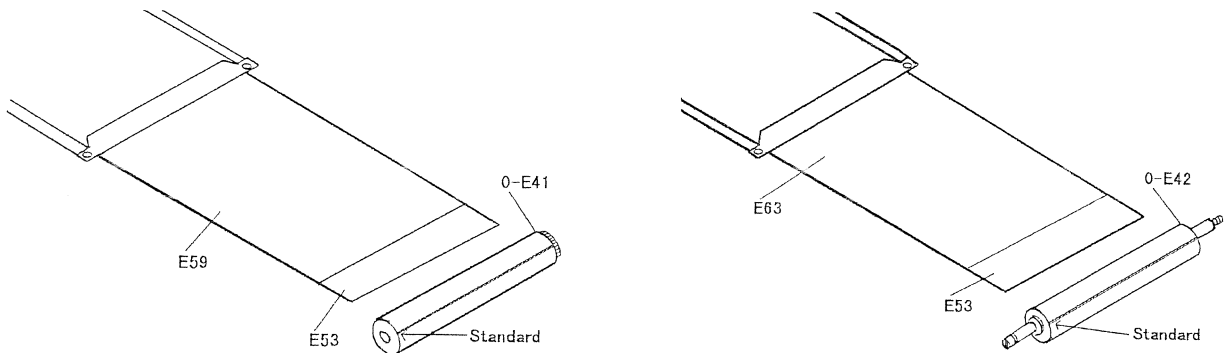

**8.3 O-E34 (2nd curtain pinion shaft), O-E35 (1st curtain pinion shaft), E51 (Curtain roller B), E66 (Curtain pipe retainer screw), O-E67 (Shaft plate A)**

- 1) Remove temporarily assembled E48, E52 and O-E49 from O-E35.
- 2) Insert O-E35 in O-E67 and apply appropriate quantity of L31 oil to O-E67 and O-E35 contact parts.
- 3) Attach E48, E52 and O-E49 to O-E35, fasten with E66 x3, and check for vertical looseness in O-E35.
- 4) Apply screw lock(1401C) to E66 x3.
- 5) Insert O-E34 into O-E67 and apply appropriate quantity of L31 oil from two vertical places on O-E67 and O-E34 contact parts.
- 6) Attach in the order B51, W8 t=0.1 (adj.) O-E41, and fasten with E66. Check that vertical looseness of O-E34 is 0.2 mm +/- 0.1. If outside this range, adjust with W8.
- 7) Apply screw lock (1401C) to E66.

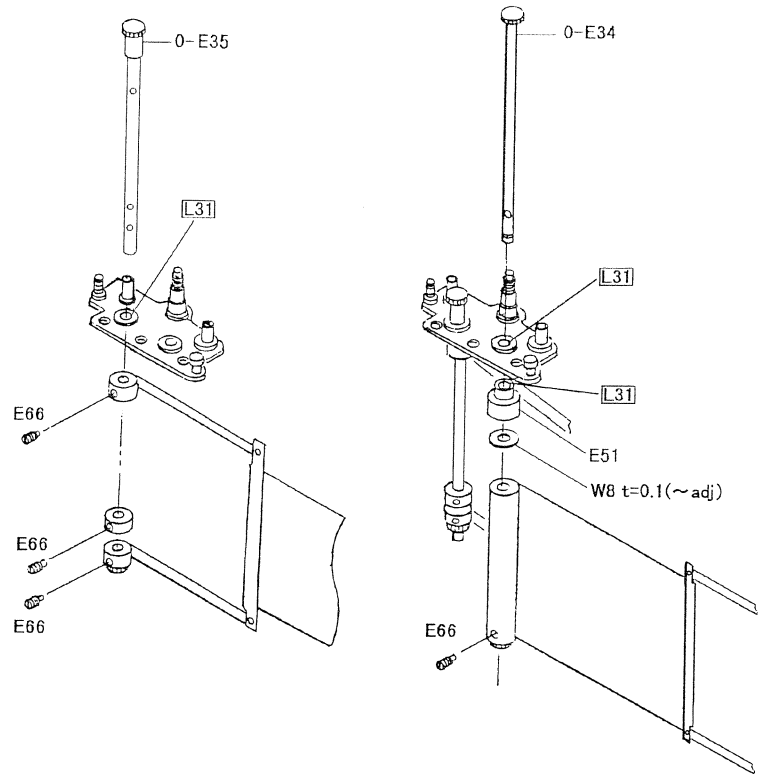

**8.4 O-E43 (2nd curtain pipe), E58 (2nd spring shaft collar), E83 (Curtain shaft wheel), E110 (Curtain shaft pedestal)**

- 1) Apply appropriate quantity of L31 oil to shaft section of O-E43, push down shaft and apply appropriate quantity of L31 oil to shaft section (inside lock washer). Move shaft section up and down and spread L31.
- 2) Insert E58 into O-E43 shaft section, hold with screwdriver and attach E83.

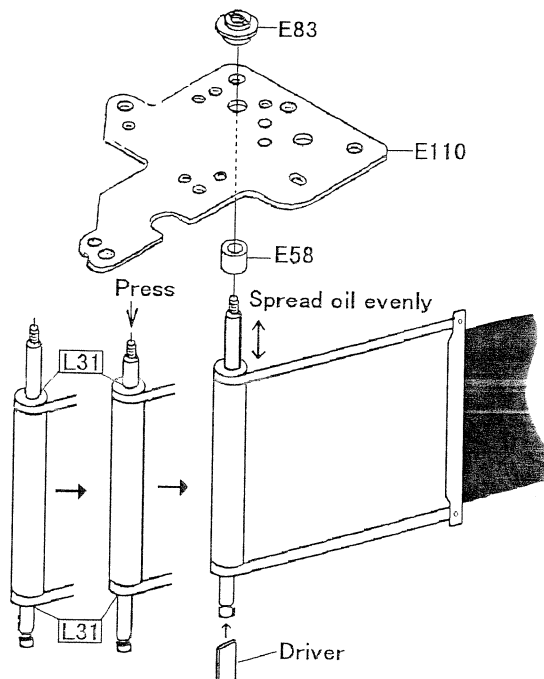

8.5 O-E42 (1st curtain pipe), E50 (Curtain roller A), E83 (Curtain shaft wheel), E110 (Curtain shaft pedestal)

- 1) Apply appropriate quantity of L31 oil to shaft section of O-E42, push down shaft and apply appropriate quantity of L31 oil. Move shaft section up and down and spread L31.
- 2) Insert F58 into O-E42 shaft section and attach to E110. Fix with screwdriver and attach E83.

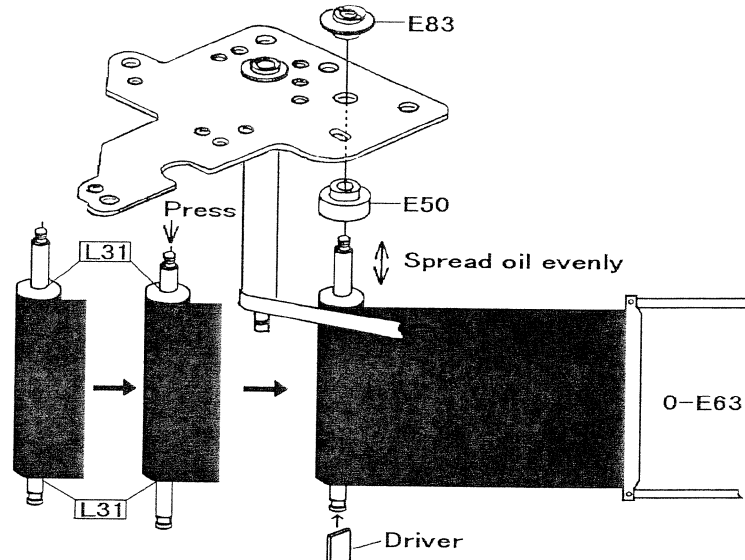

8.6 E69 (Shaft plate C)

- 1) Insert into O-E42 in the order W8 t=0.1 (~adj.), E50. Align with shaft sections of O-E42 and O-E43, attach E69, insert W8 t=0.2 (~adj.), and fasten with LW20.
2. Apply appropriate quantity of L31 oil from side of LW20 attachment section to hole section of E69 bearing.

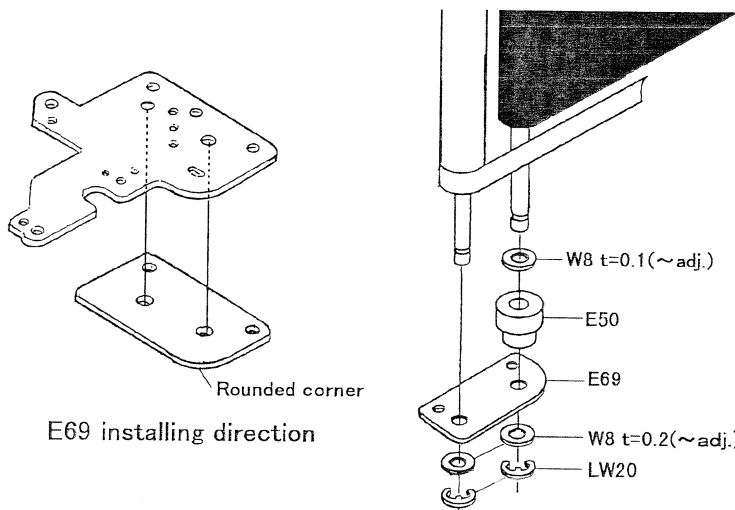

8.7 Structural drawings of 1st and 2nd curtains

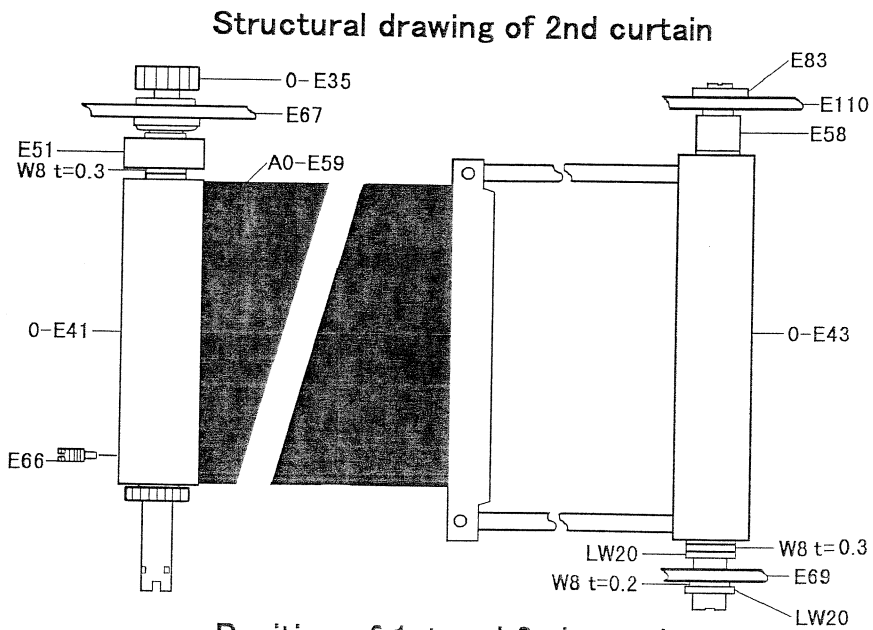
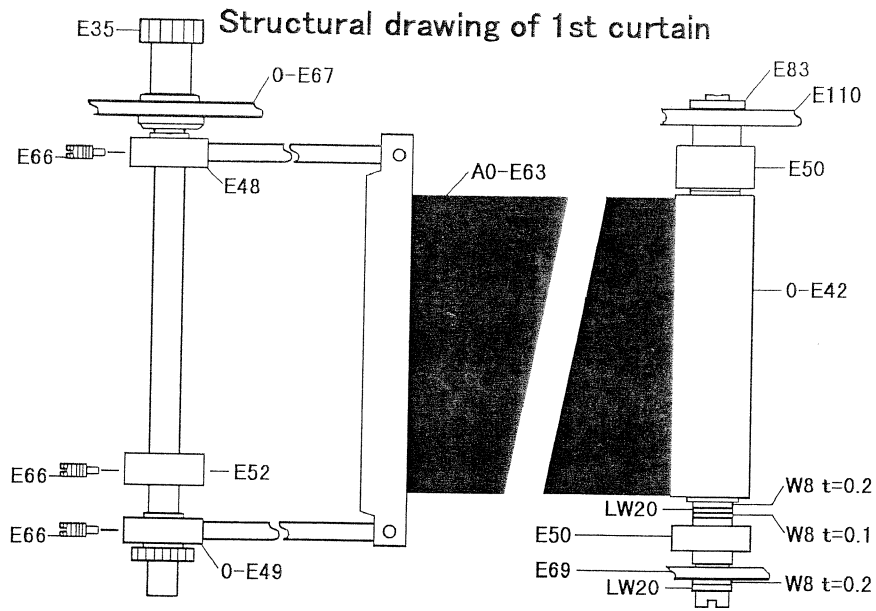

Position of 1st and 2nd curtain

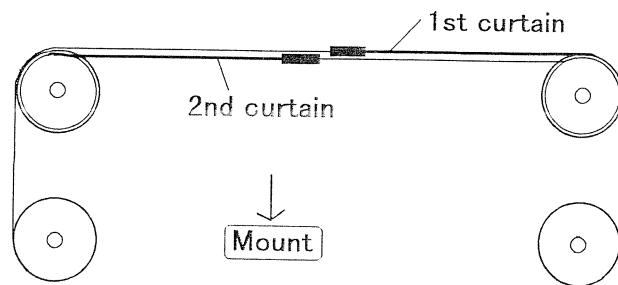

## 9. L1 (Main mirror) attachment

[ Adhesive ] : 95901 S114 Cemedine Super X 8008 B (black)

### 9.1

- 1) Remove any dust or dirt from adhesive surfaces of L1 and mirror sheet.
- 2) Apply Super X (black) to mirror sheet as shown in drawing.
- 3) Attach L1 to mirror sheet, pressurize L1 lightly in 4 places and check attachment position.  
Note: Move part ④ downwards as downward pressure is applied.
- 4) Leave L1 undisturbed for at least 12 hours in a horizontal position.

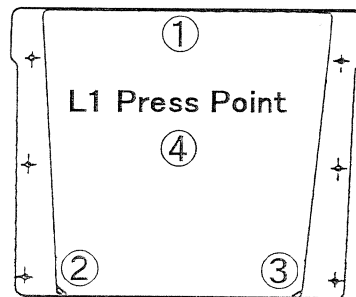
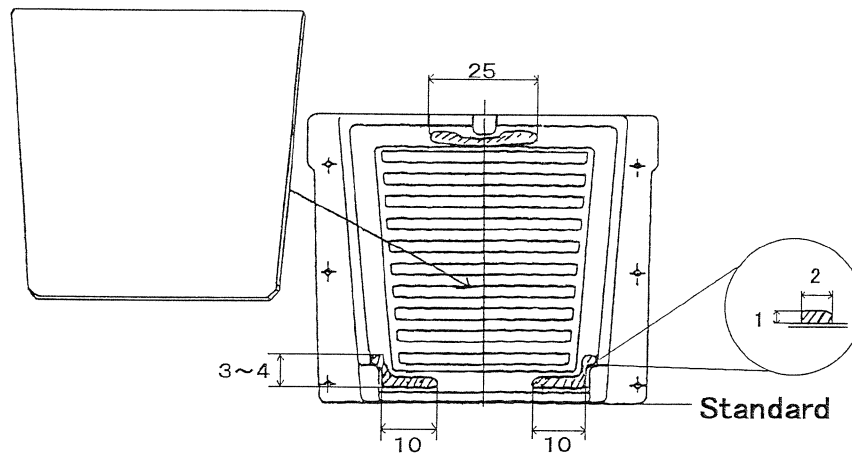

10. Folding of T100 (main P.C. board), etc.

(The following explanation is concerned with operations performed when exchanging T100.)

10.1 Fold T100 in a V shape and an inverted V shape.

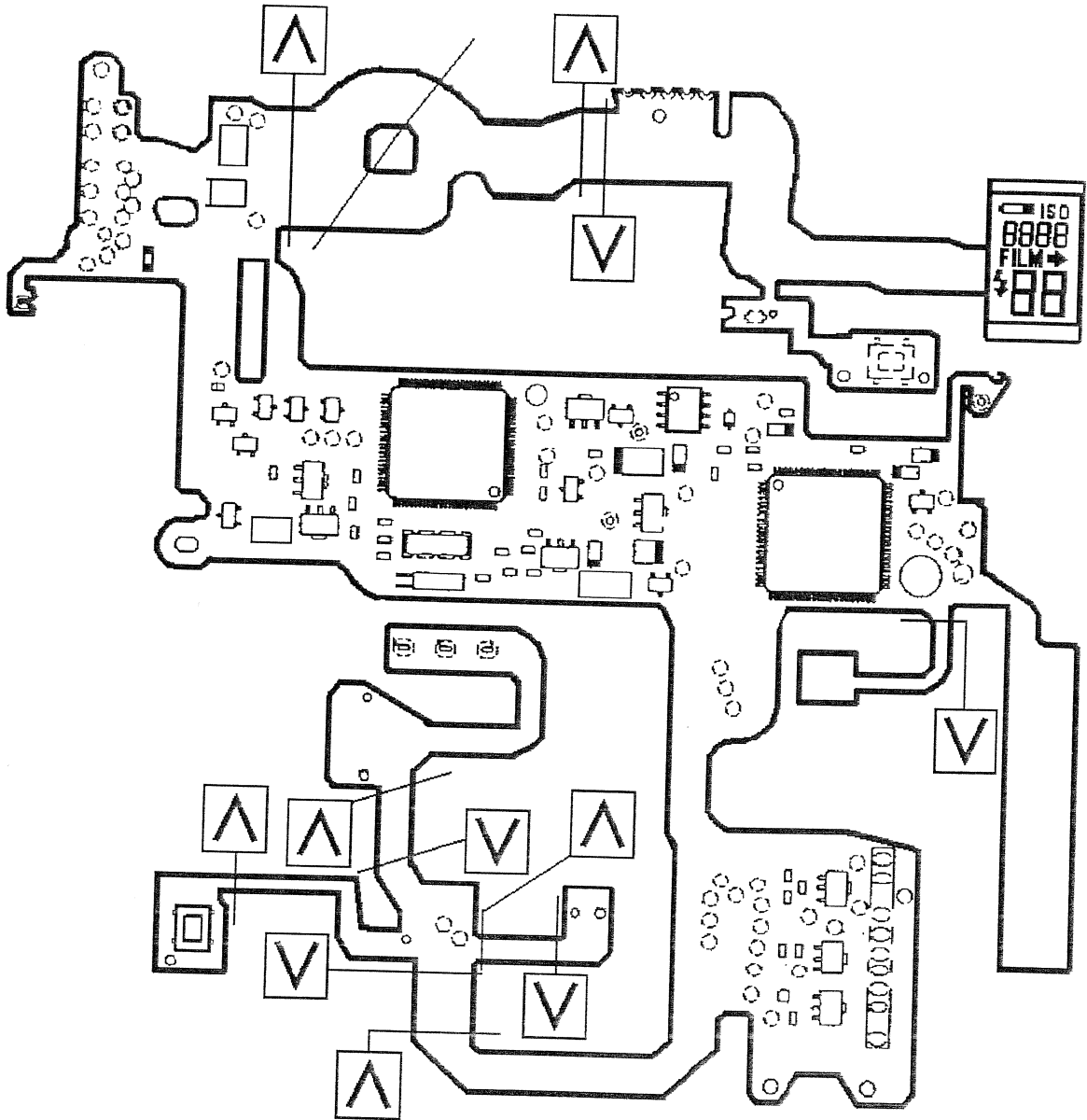

## 10.2

- 1) Attach DT(5 x25) and DT(6 x20) in specified positions on main P.C. board install plate A.
- 2) Attach DT(10 x20) in specified positions on main P.C. board install plate B.

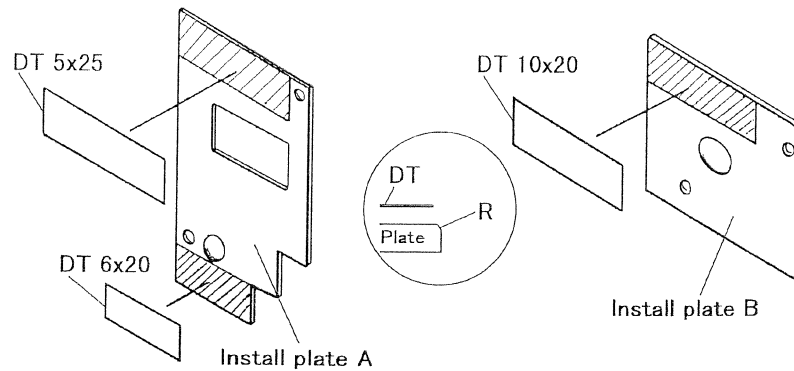

## 10.3

- 1) Attach main P.C. board install plate A, B, T13 (Main P.C. board install plate tape C) in specified positions.

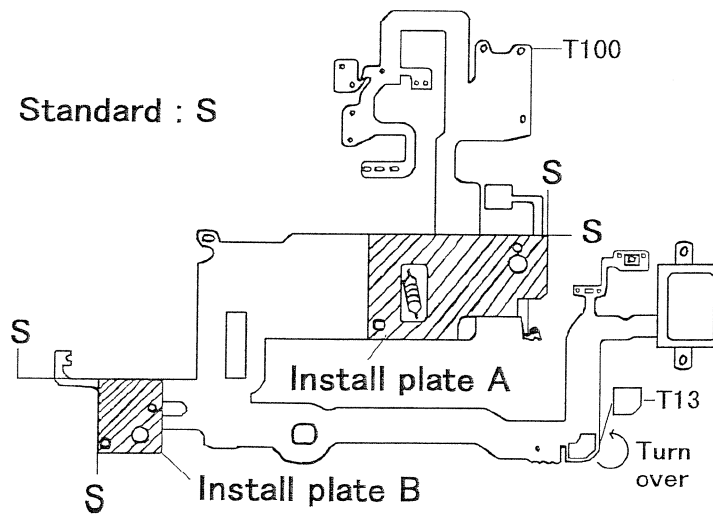

## 10.4

- 1) Align two terminals of S300 with T100 land and solder.

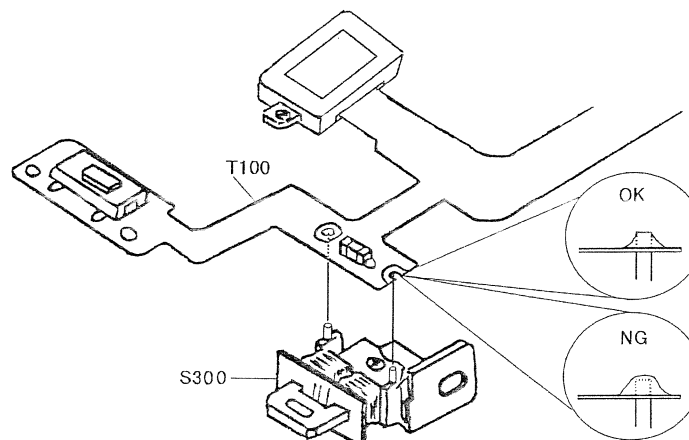



## LIST OF JIGS, TOOLS AND TESTING EQUIPMENT FOR 27340

<b>* Used exclusively by 27340</b>	<b>Order no.</b>
1. Program software for 27340	
AT-compatible unit for 3.5 inch use (contained in SS-A)	95901-P243
PC 98 type for 3.5 inch use (contained in SN-A)	95901-P023
PC 98 type for 5.0 inch use (contained in AN-A)	95901-P123
2. Driver bit for 27340-M11-A	95901-K280
3. Check jig for C30 block	95901-K281
4. Camera adaptor CAA-27340	95901-M129
5. 67 II TTL Back plate for 27340	95901-J131
6. Silicon rubber TSE 397	95901-S141
<b>* Others</b>	
1. Personal computer	N/A
2. Color display	N/A
3. Shutter tester (EF-8000)	95901-M049-01
Shutter tester (EF-5000)	95901-M003-01
4. Camera multi-adaptor-A	95901-M127
5. Standard lens for AE (Use 105mm/F2.8 standard lens)	N/A
6. Focus master lens 67	95901-N19
7. Dial gauge comparator PH-2	95901-N001
8. Block gauge for 23400N-A01-A	95901-N008
9. Mount block 23400J-B02-A	95901-N009
10. 23400K-C73-A Driver bit	95901-K159
11. 23400N-B01-A (Mirror angle adjusting jig)	95901-N035
12. 23400K-A67-A1 Spanner	95901-K145
13. Driver 23400K-A9, A65-A	95901-K180
14. Driver bit 23400K-E80-A	95901-K165
15. Colimator	N/A
16. Regulated DC power supply	N/A
17. Circuit tester	N/A

Programmed Soft Flow chart

PAGE 1

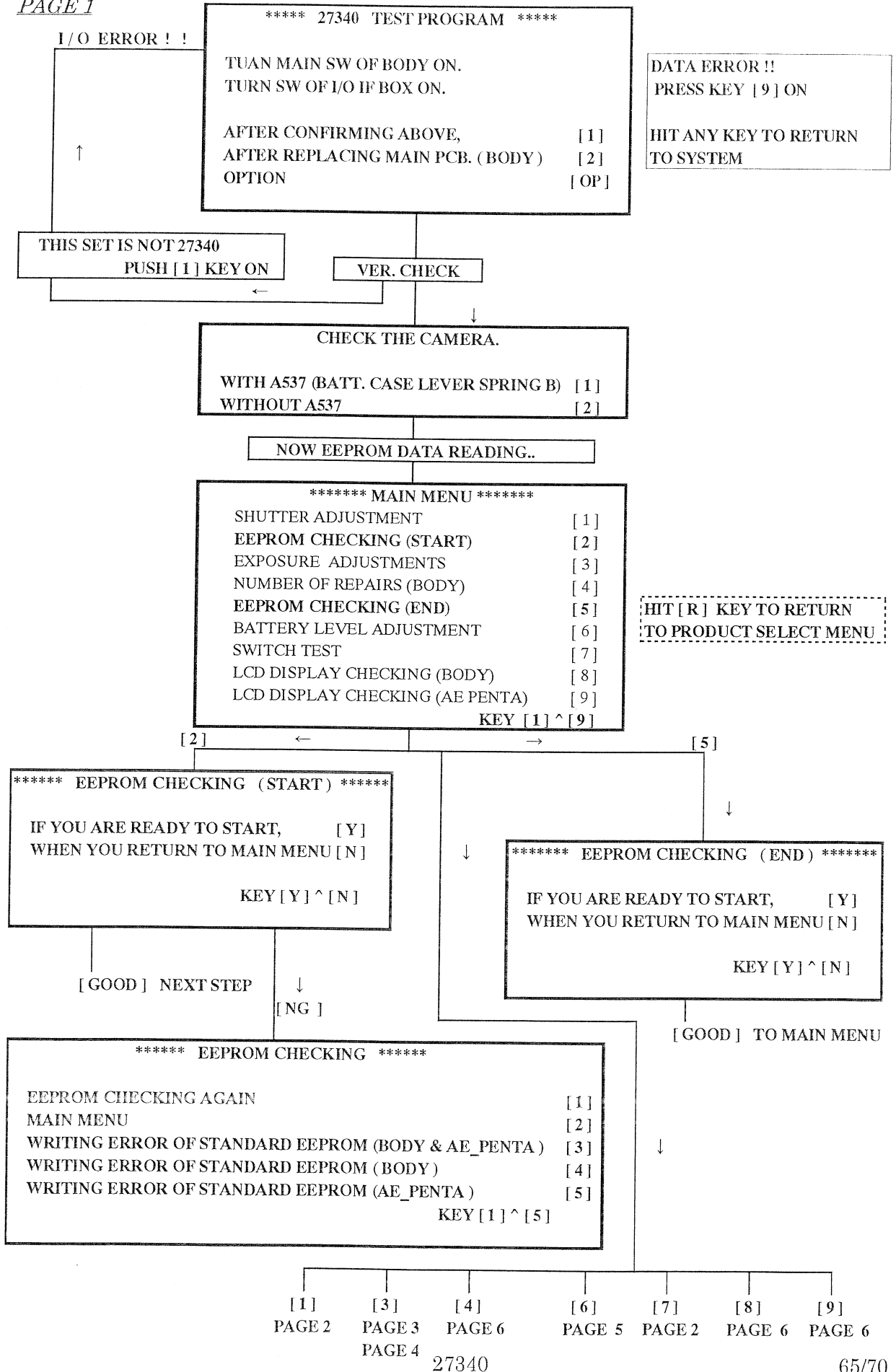

```

***** MAIN MENU *****

SHUTTER ADJUSTMENT           [ 1 ]
EEPROM CHECKING (START)      [ 2 ]
EXPOSURE ADJUSTMENTS        [ 3 ]
NUMBER OF REPAIRS (BODY)    [ 4 ]
EEPROM CHECKING (END)       [ 5 ]
BATTERY LEVEL ADJUSTMENT    [ 6 ]
SWITCH TEST                  [ 7 ]
LCD DISPLAY CHECKING (BODY) [ 8 ]
LCD DISPLAY CHECKING (AE PENTA) [ 9 ]

KEY [ 1 ] ^ [ 9 ]

```

```

***** SHUTTER SPEED ADJUSTMENT *****

1) SET THE CAMERA ON THE SHUTTER TESTER.
2) CHARGE THE SHUTTER

IF YOU ARE READY TO RELEASE, ( 1/1000 ) [ 1 ]
AND READ SHUTTER SPEED.      ( 1/500 ) [ 2 ]
                             ( 1/250 ) [ 3 ]

NEXT OF SHUTTER SPEED ADJUSTMENT, [ Y ]
WHEN YOU RETURN TO FRONT MENU, [ N ]

```

```

INPUT DATA OF SHUTTER SPEED.

( 1/1000 ) DATA ( mSEC. ) = ?
( 1/500 )  DATA ( mSEC. ) = ?
( 1/250 )  DATA ( mSEC. ) = ?

( WHEN YOU RETURN TO FRONT MENU, [ N ] )

```

```

***** SWITCH TEST *****
* ***** *
* MAIN_SW      SELF          SWS          SWR          *
* MULTI_EXPOSURE          A/M_SW ( LENS ) *
* WIND_POSITION  MID-WINDING *
* ML            M. UP        X_SW ( I230 )  CHARGE_END ( D72 ) *
* ISO           ISO_UP       ISO_DOWN          *
* TV_E3         TV_E2        TV_E1           TV_E0          *
* BACK_COVER    I20_220      MAT_1          MAT_0          *
* ***** *

```

\*\*\*\*\* MAIN MENU \*\*\*\*\*

SHUTTER ADJUSTMENT	[ 1 ]
EEPROM CHECKING (START)	[ 2 ]
EXPOSURE ADJUSTMENTS	[ 3 ]
NUMBER OF REPAIRS (BODY)	[ 4 ]
EEPROM CHECKING (END)	[ 5 ]
BATTERY LEVEL ADJUSTMENT	[ 6 ]
SWITCH TEST	[ 7 ]
LCD DISPLAY CHECKING (BODY)	[ 8 ]
LCD DISPLAY CHECKING (AE PENTA)	[ 9 ]

KEY [ 1 ] ^ [ 9 ]

[ 3 ] \*\*\*\*\* SELECT AE TYPE \*\*\*\*\*

TYPE 1 ( LV 6 , 8 , 10 , 12 , 16 )	[ 1 ]
TYPE 2 ( LV 6 , 9 , 12 , 15 )	[ 2 ]

\*\*\*\*\* EXPOSURE ADJUSTMENTS \*\*\*\*\*

TEMP. ADJUSTMENT	[ 1 ]
AV ADJUSTMENT	[ 2 ]
BV ADJUSTMENT ( AE PENTA )	[ 3 ]
TTL FLASH QUENCH SIGNAL ADJUSTMENT	[ 4 ]
MAIN MENU	[ 5 ]

KEY [ 1 ] ^ [ 5 ]

[ 1 ] \*\*\*\*\* TEMP. ADJUSTMENT \*\*\*\*\*

CHECK ROOM TEMPERATURE.

AFTER CONFIRMING ABOVE, [ Y ]  
WHEN YOU RETURN TO FRONT MENU [ N ]

DATA IS BEING READ.

INPUT ROOM TEMPERATURE.

< C > -----	[ 1 ]
< F > -----	[ 2 ]

INPUT ROOM TEMPERATURE < C > ?

\*\*\*\*\* TEMP. ADJUSTMENT \*\*\*\*\*

TEMP. ADJUSTMENT HAS BEEN COMPLETED.

TEMP. ADJUSTMENT AGAIN	[ 1 ]
NEXT OF AV ADJUSTMENT	[ 2 ]
EXPOSURE ADJUSTMENTS MENU	[ 3 ]

[ 2 ] \*\*\*\*\* AV ADJUSTMENT \*\*\*\*\*

MOUNT 67 LENS F2.4 / 105mm.  
SET THE LENS TO F8

AFTER CONFIRMING ABOVE, [ Y ]  
WHEN YOU RETURN TO FRONT MENU [ N ]

\*\*\*\*\* AV ADJUSTMENT \*\*\*\*\*

BEING ADJUSTED.

\*\*\*\*\* AV ADJUSTMENT \*\*\*\*\*

AV ADJUSTMENT HAS BEEN COMPLETED.

AV ADJUSTMENT AGAIN	[ 1 ]
NEXT OF BV ADJUSTMENT	[ 2 ]
EXPOSURE ADJUSTMENTS MENU	[ 3 ]
MAIN MENU	[ 4 ]

[ 3 ] [ 4 ]

\*\*\*\*\* MAIN MENU \*\*\*\*\*

SHUTTER ADJUSTMENT	[ 1 ]
EEPROM CHECKING (START)	[ 2 ]
EXPOSURE ADJUSTMENTS	[ 3 ]
NUMBER OF REPAIRS (BODY)	[ 4 ]
EEPROM CHECKING (END)	[ 5 ]
BATTERY LEVEL ADJUSTMENT	[ 6 ]
SWITCH TEST	[ 7 ]
LCD DISPLAY CHECKING (BODY)	[ 8 ]
LCD DISPLAY CHECKING (AE PENTA)	[ 9 ]
KEY [ 1 ] ^ [ 9 ]	

[ 3 ] \*\*\*\*\* SELECT AE TYPE \*\*\*\*\*

TYPE 1 ( LV 6 , 8 , 10 , 12 , 16 )	[ 1 ]
TYPE 2 ( LV 6 , 9 , 12 , 15 )	[ 2 ]

\*\*\*\*\* EXPOSURE ADJUSTMENTS \*\*\*\*\*

TEMP. ADJUSTMENT	[ 1 ]
AV ADJUSTMENT	[ 2 ]
BV ADJUSTMENT ( AE PENTA )	[ 3 ]
TTL FLASH QUENCH SIGNAL ADJUSTMENT	[ 4 ]
MAIN MENU	[ 5 ]
KEY [ 1 ] ^ [ 5 ]	

\*\*\*\*\* BV ADJUSTMENT \*\*\*\*\*

MOUNT 67 LENS F2.4 / 105mm.  
SET THE LENS TO F8  
SET LIGHT SOURCE TO LV 6

AFTER CONFIRMING ABOVE, [ Y ]  
WHEN YOU RETURN TO FRONT MENU [ N ]

\*\*\*\*\* TTL QUENCH SIGNAL ADJUSTMENT \*\*\*\*\*

MOUNT 67 LENS F2.4 / 105mm.  
SET THE LENS TO F2.4  
SET LIGHT SOURCE TO LV 10  
ATTACH TTL ADJUSTING PLATE ONTO CAMERA.

AFTER CONFIRMING ABOVE, [ Y ]  
WHEN YOU RETURN TO FRONT MENU, [ N ]

\*\*\* BV ADJUSTMENT \*\*\*

BEING ADJUSTED.

\*\*\*\*\* TTL QUENCH SIGNAL ADJUSTMENT \*\*\*\*\*

BEING ADJUSTED

TTL QUENCH SIGNAL ADJUSTMENT  
HAS BEEN COMPLETED

TTL QUENCH SIGNAL ADJUSTMENT AGAIN	[ 1 ]
EXPOSURE ADJUSTMENTS MENU	[ 2 ]
MAIN MENU	[ 3 ]

\*\*\*\*\* BV ADJUSTMENT \*\*\*\*\*

SET LIGHT SOURCE TO LV 15.

AFTER CONFIRMING ABOVE, [ Y ]  
WHEN YOU RETURN TO FRONT MENU [ N ]

\*\*\*\*\* BV CHECK \*\*\*\*\*

SET LIGHT SOURCE TO LV 12.

AFTER CONFIRMING ABOVE, [ Y ]  
WHEN YOU RETURN TO FRONT MENU [ N ]

\*\*\*\*\* BV ADJUSTMENT \*\*\*\*\*

BV ADJUSTMENT HAS BEEN COMPLETED.

BV ADJUSTMENT AGAIN	[ 1 ]
NEXT OF TTL FLASH QUENCH SIGNAL ADJUSTM	[ 2 ]
EXPOSURE ADJUSTMENTS MENU	[ 3 ]
MAIN MENU	[ 4 ]

[ 4 ] MAIN MENU

\*\*\*\*\* MAIN MENU \*\*\*\*\*

SHUTTER ADJUSTMENT	[ 1 ]
EEPROM CHECKING (START)	[ 2 ]
EXPOSURE ADJUSTMENTS	[ 3 ]
NUMBER OF REPAIRS (BODY)	[ 4 ]
EEPROM CHECKING (END)	[ 5 ]
BATTERY LEVEL ADJUSTMENT	[ 6 ]
SWITCH TEST	[ 7 ]
LCD DISPLAY CHECKING (BODY)	[ 8 ]
LCD DISPLAY CHECKING (AE PENTA)	[ 9 ]

KEY [ 1 ] ^ [ 9 ]

\*\*\*\*\* BATTERY LEVEL ADJUST \*\*\*\*\*

1) REMOVE BATTERIES AND REINSTALL THE BATTERY COVER.  
2) ATTACH REGULATED DC POWER SUPPLY TO CAMERA ADAPTER.  
3) SET REGULATED DC POWER SUPPLY TO 6 V

AFTER CONFIRMING ABOVE, [ Y ]  
WHEN YOU RETURN TO FRONT MENU, [ N ]

\*\*\*\*\* BATTERY LEVEL ADJUST \*\*\*\*\*

\* SET REGULATED DC POWER SUPPLY TO 4.5 V  
(MORE THAN 3 AMPERE )

AFTER CONFIRMING ABOVE, [ Y ]  
WHEN YOU RETURN TO FRONT MENU, [ N ]

\*\*\*\*\* BATTERY LEVEL ADJUST \*\*\*\*\*

DATA IS BEING READ. 3

\*\*\*\*\* BATTERY LEVEL ADJUST \*\*\*\*\*

\* SET REGULATED DC POWER SUPPLY TO 4.2 V (MORE THAN 3 AMPERE )

AFTER CONFIRMING ABOVE, [ Y ]  
WHEN YOU RETURN TO FRONT MENU, [ N ]

\*\*\*\*\* BATTERY LEVEL ADJUST \*\*\*\*\*

DATA IS BEING READ CHECKING HAS BEEN COMPLETED.  
DOES THIS DATA WRITE TO EEPROM?

IF YOU ARE READY TO START, [ Y ]  
WHEN DO NOT WRITE DATA, [ N ]

BATTERY DATA WRITING HAS BEEN COMPLETED

\*\*\*\*\* BATTERY LEVEL ADJUST \*\*\*\*\*

BATTERY DATA WRITING HAS BEEN COMPLETED.  
\* SET REGULATED DC POWER SUPPLY TO 6 V

BATTERY LEVEL ADJUST AGAIN [ 1 ]  
MAIN MENU [ 2 ]

[ 2 ] MAIN MENU

\*\*\*\*\* MAIN MENU \*\*\*\*\*  
SHUTTER ADJUSTMENT [ 1 ]  
EEPROM CHECKING (START) [ 2 ]  
EXPOSURE ADJUSTMENTS [ 3 ]  
NUMBER OF REPAIRS (BODY) [ 4 ]  
EEPROM CHECKING (END) [ 5 ]  
BATTERY LEVEL ADJUSTMENT [ 6 ]  
SWITCH TEST [ 7 ]  
LCD DISPLAY CHECKING (BODY) [ 8 ]  
LCD DISPLAY CHECKING (AE PENTA) [ 9 ]  
KEY [ 1 ] ^ [ 9 ]

[ 4 ] ↓

\*\*\*\*\* NUMBER OF REPAIRS \*\*\*\*\*  
NUMBER OF REPAIRS = 1 -----2  
IF YOU ARE READY TO START, [ Y ]  
WHEN YOU RETURN TO FRONT MENU [ N ]  
NEXT OF EEPROM CHECKING ( END ) --- [ 1 ]

[ 8 ] ↓

\*\*\*\*\* LCD DISPLAY CHECKING \*\*\*\*\*  
( BODY )  
IF YOU ARE READY TO START, [ Y ]  
WHEN YOU RETURN TO FRONT MENU [ N ]

↓

[ Y ]  
LCD OFF AT [ ENTER ] ?  
LCD TEST END AT [ ENTER ] ?

→ [ 9 ] ↓

\*\*\*\*\* LCD DISPLAY CHECKING \*\*\*\*\*  
( AE PENTA )  
IF YOU ARE READY TO START, [ Y ]  
WHEN YOU RETURN TO FRONT MENU [ N ]

↓

[ Y ]  
LCD OFF AT [ ENTER ] ?  
LCD TEST END AT [ ENTER ] ?

**PENTAX®**

# Service Parts List

## **PENTAX 67II**



**Product No.27340**





# EXPLODED ILLUSTRATION

- Ⓞ : G21
- Ⓞ<sub>G126</sub> : G126
- Ⓞ<sub>G134</sub> : G134
- ▭<sub>L114</sub> : Oil barrier
- ▭<sub>L115</sub> : DRY SURF
- Ⓢ<sub>L</sub> : Threebond 1401C
- Ⓢ : Arontite (Blue)
- Ⓢ : Arontite (Red)
- Ⓢ : Dia bond

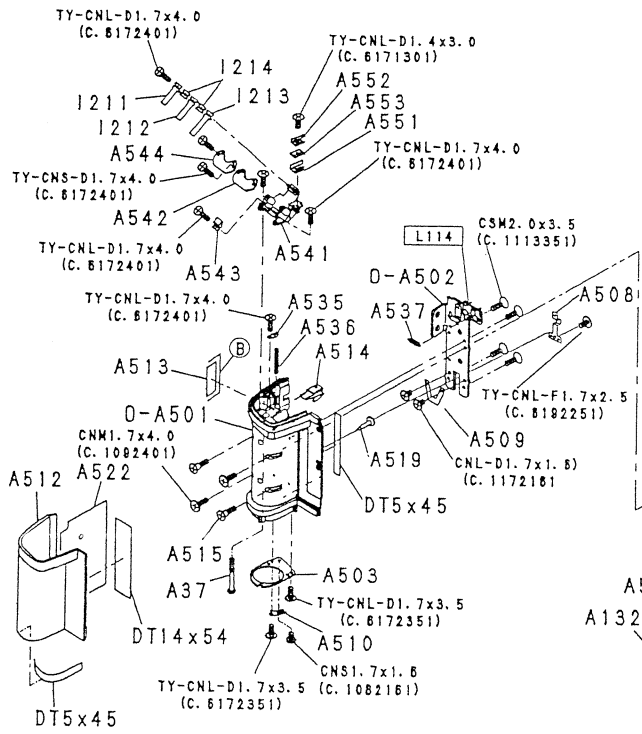
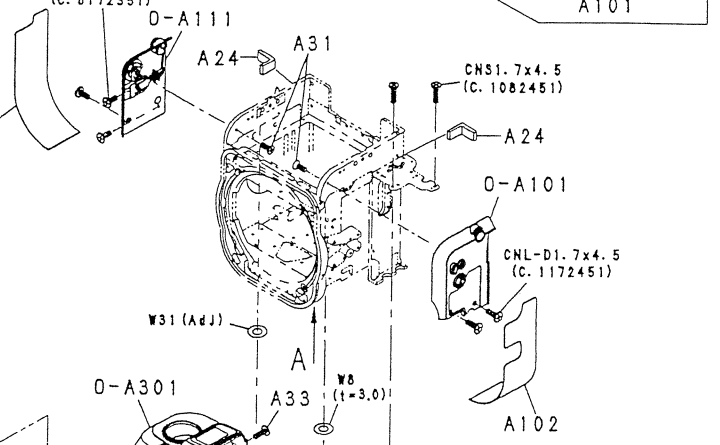
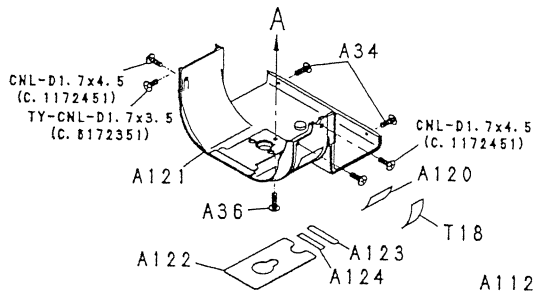
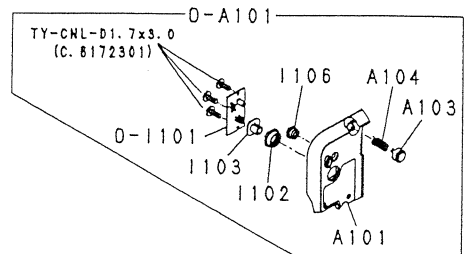
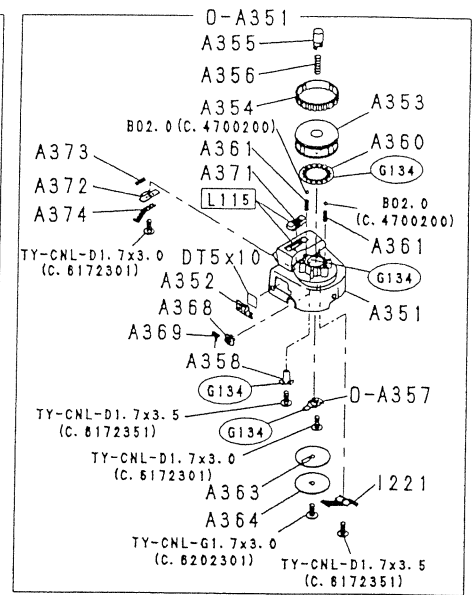
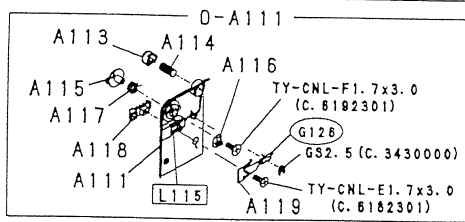
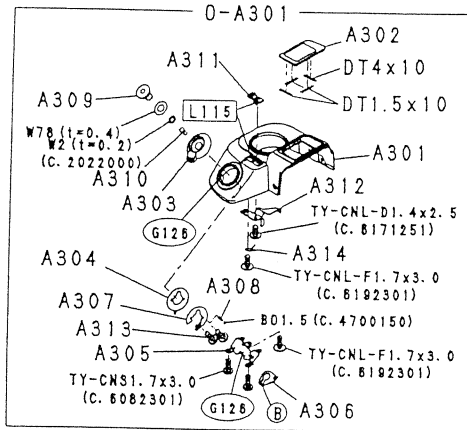
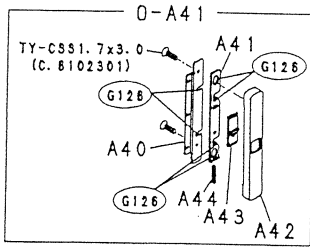

Product No.27340

PENTAX 67II

Fig. 1

# EXPLODED ILLUSTRATION

G	: G21
G126	: G126
G134	: G134
L114	: Oil barrier
SL	: Threebond 1401C
L	: Arontite (Blue)
R	: Arontite (Red)

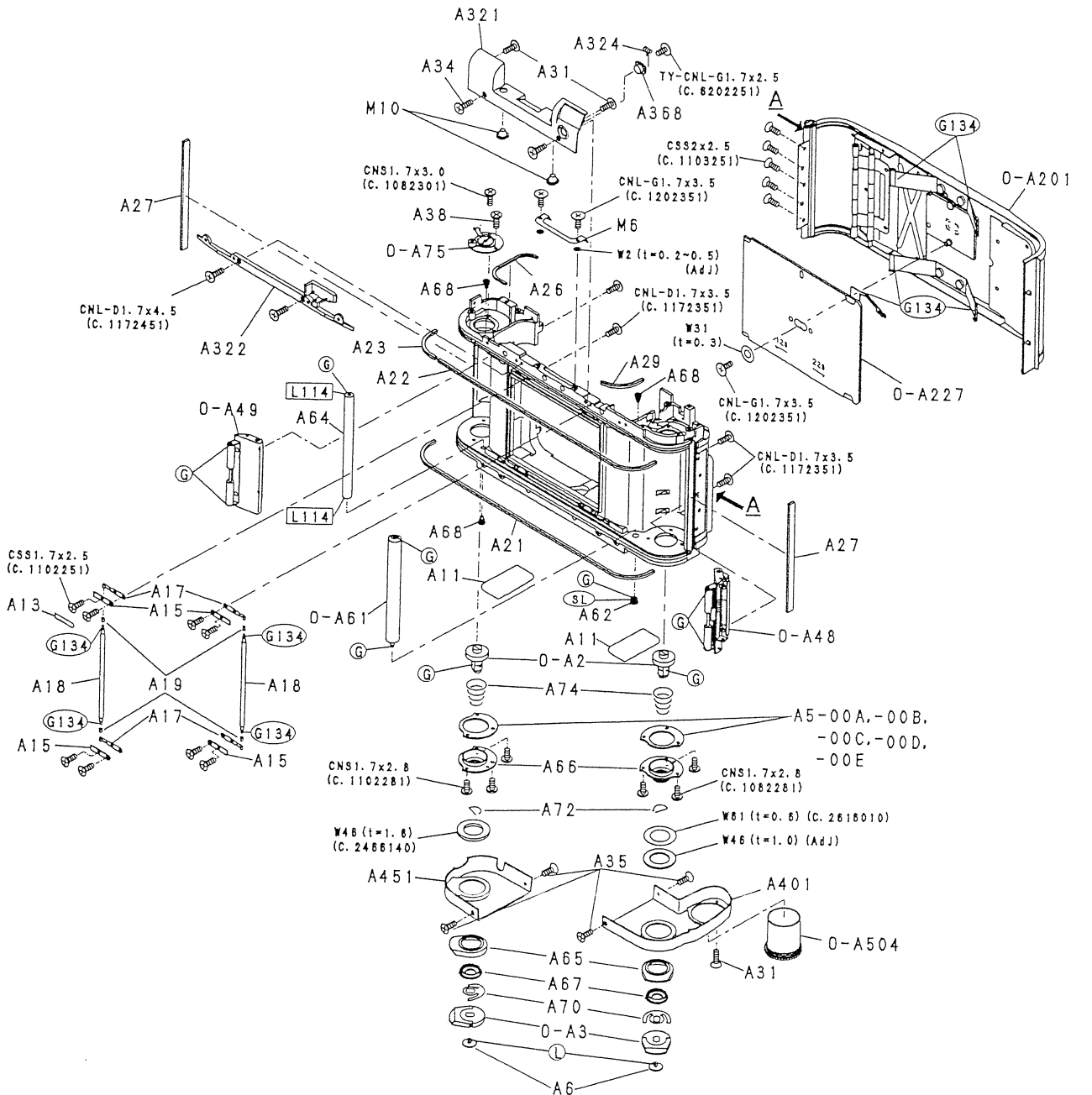
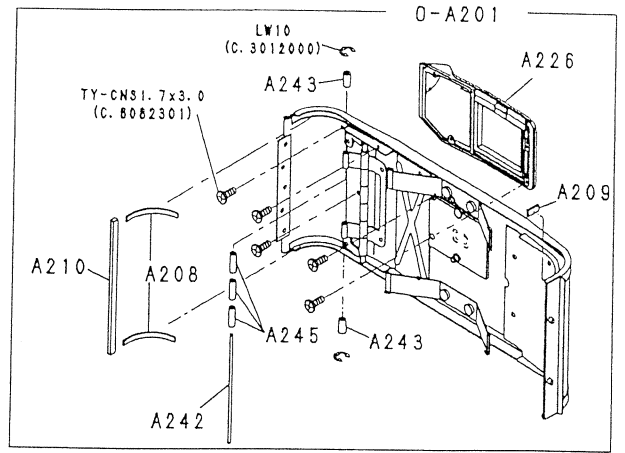

**Product No.27340**  
**PENTAX 67II**

Fig. 2

# EXPLODED ILLUSTRATION

- Ⓒ : G21
- Ⓓ : Arontite (Red)
- Ⓛ : Threabond 1401C
- L114 : Oil barrier

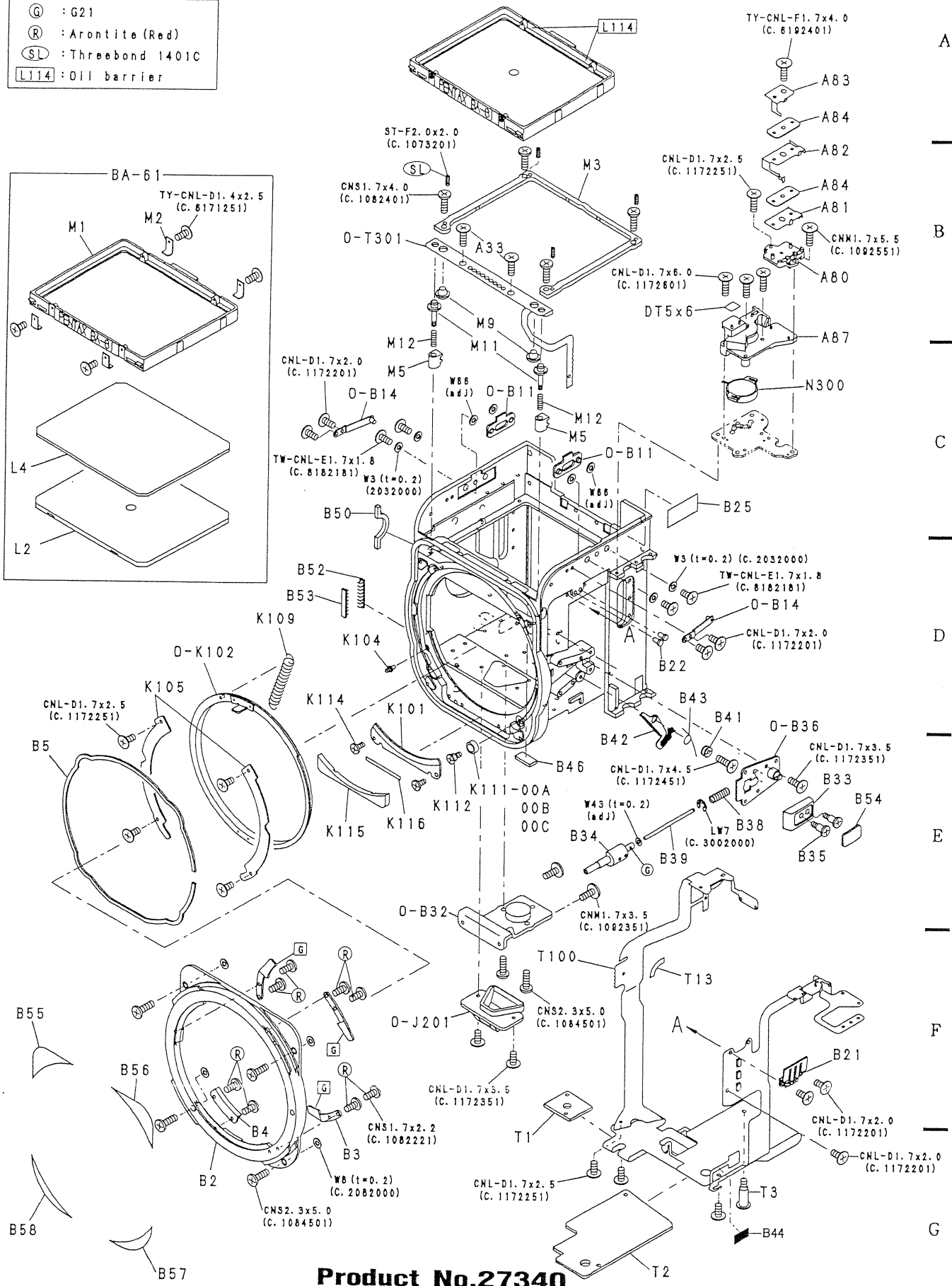
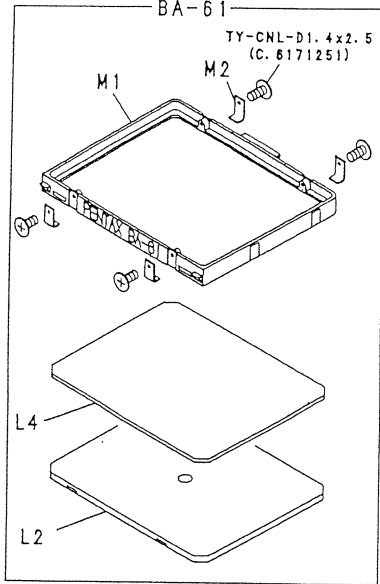

A  
—  
B  
—  
C  
—  
D  
—  
E  
—  
F  
—  
G

Product No.27340

## PENTAX 67II

Fig. 3

# EXPLODED ILLUSTRATION

- ⊙ : G21
- ⊠ : G31
- L114 : Oil barrier
- ⊙SL : Threebond 1401C
- ⊙S : Silicon TSE397
- ⊙X : GEMEDINE SUPER-X(B)

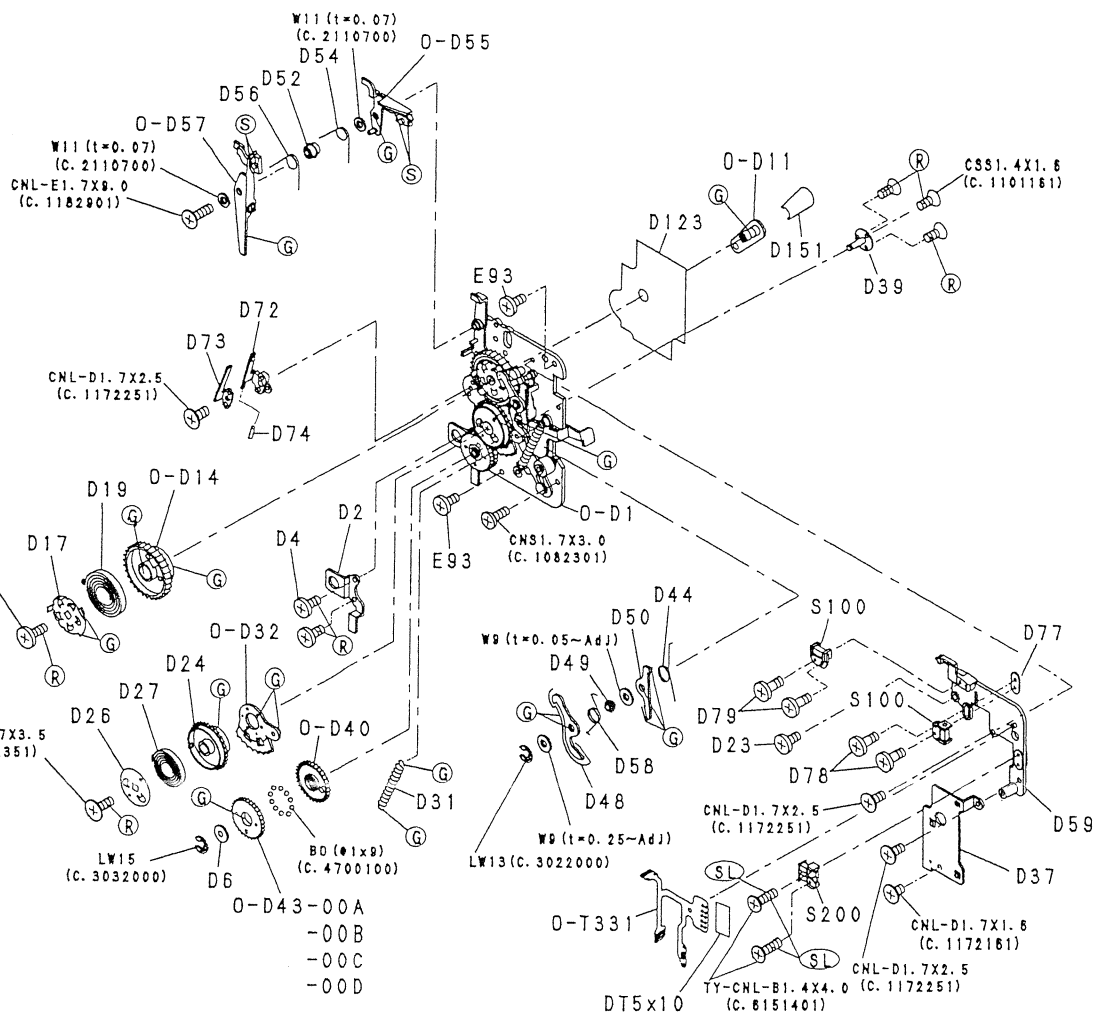
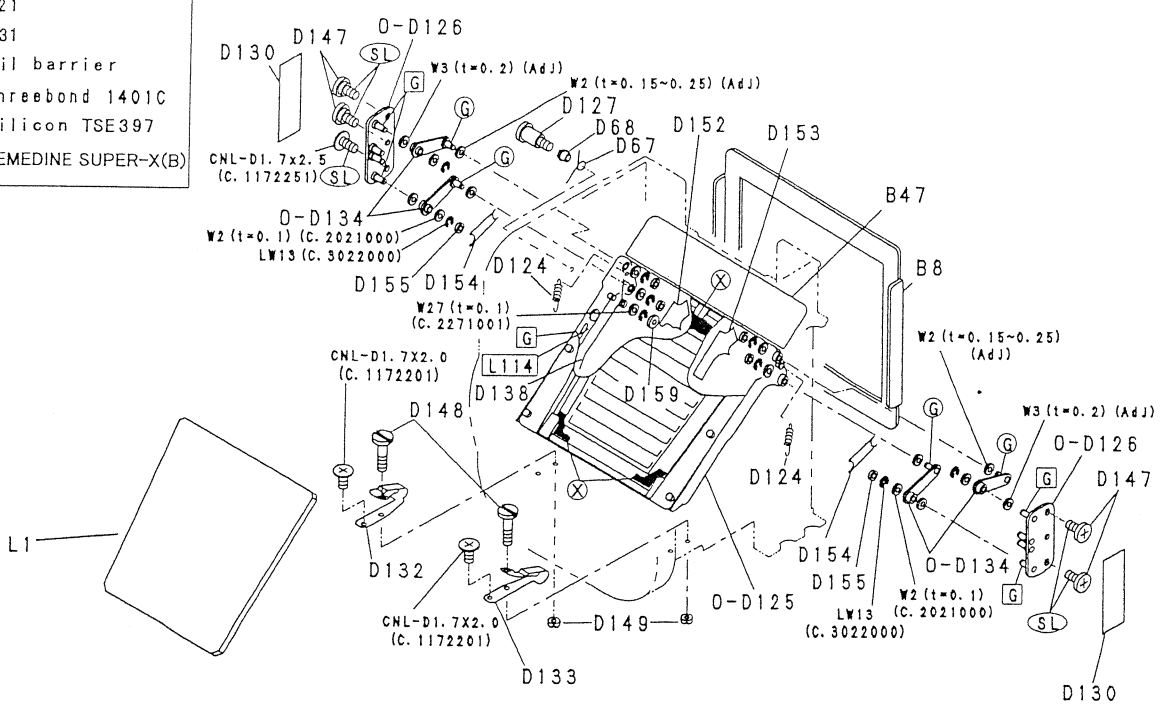

A  
—  
B  
—  
C  
—  
D  
—  
E  
—  
F  
—  
G

**Product No.27340**  
**PENTAX 67II**

Fig.4

+

1

2

3

4

5

# EXPLODED ILLUSTRATION

Ⓞ	: G21
Ⓞ	: G31
L31	: L31
Ⓞ	: Threebond 1401C

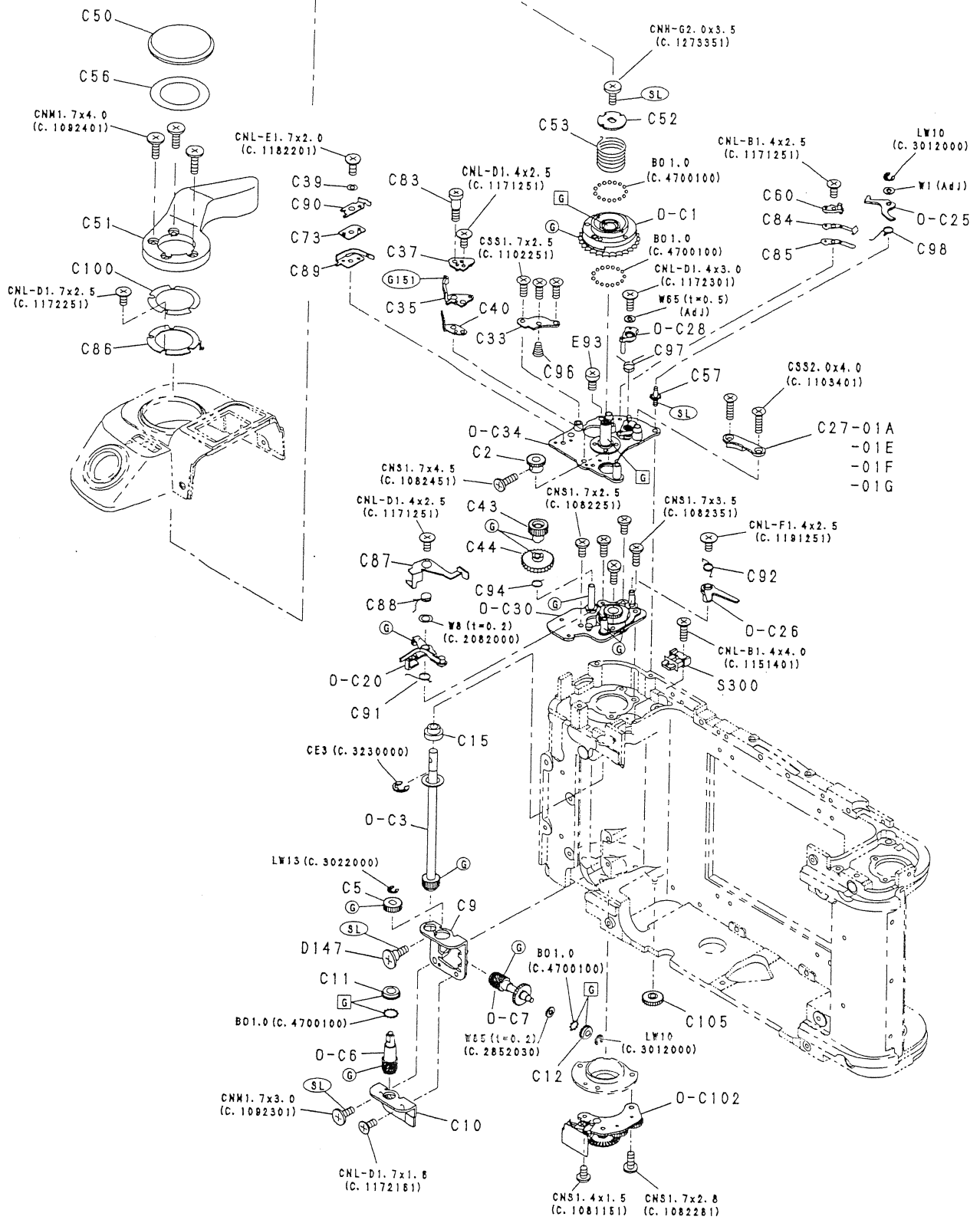

A  
B  
C  
D  
E  
F  
G

Product No.27340  
**PENTAX 67II**

Fig. 5  
5

1 | 2 | 3 | 4 | 5

# EXPLODED ILLUSTRATION

⊙ : G21  
 L31 : L31

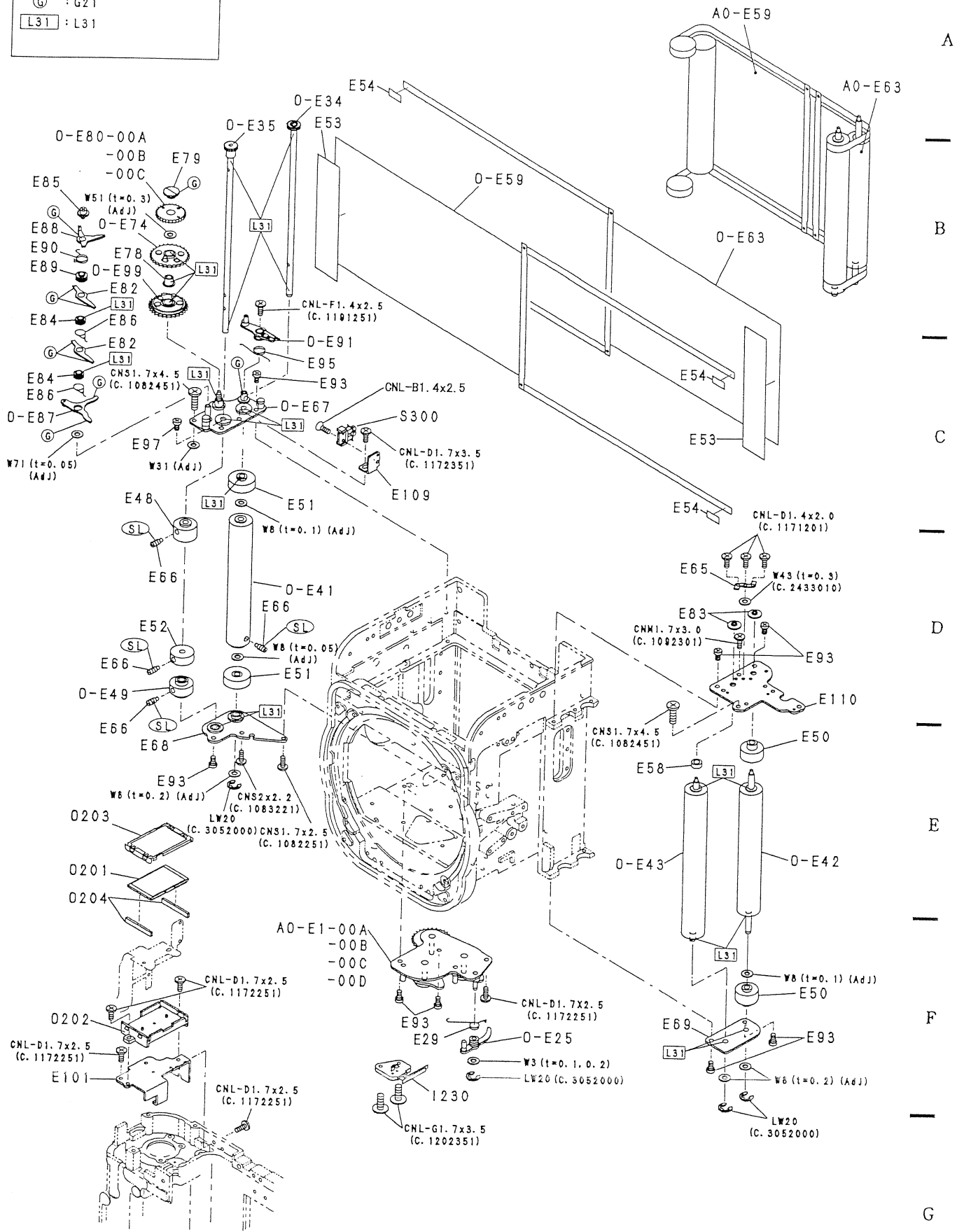

Product No.27340  
**PENTAX 67II**

Fig. 6

# DISTRIBUTING WIRES

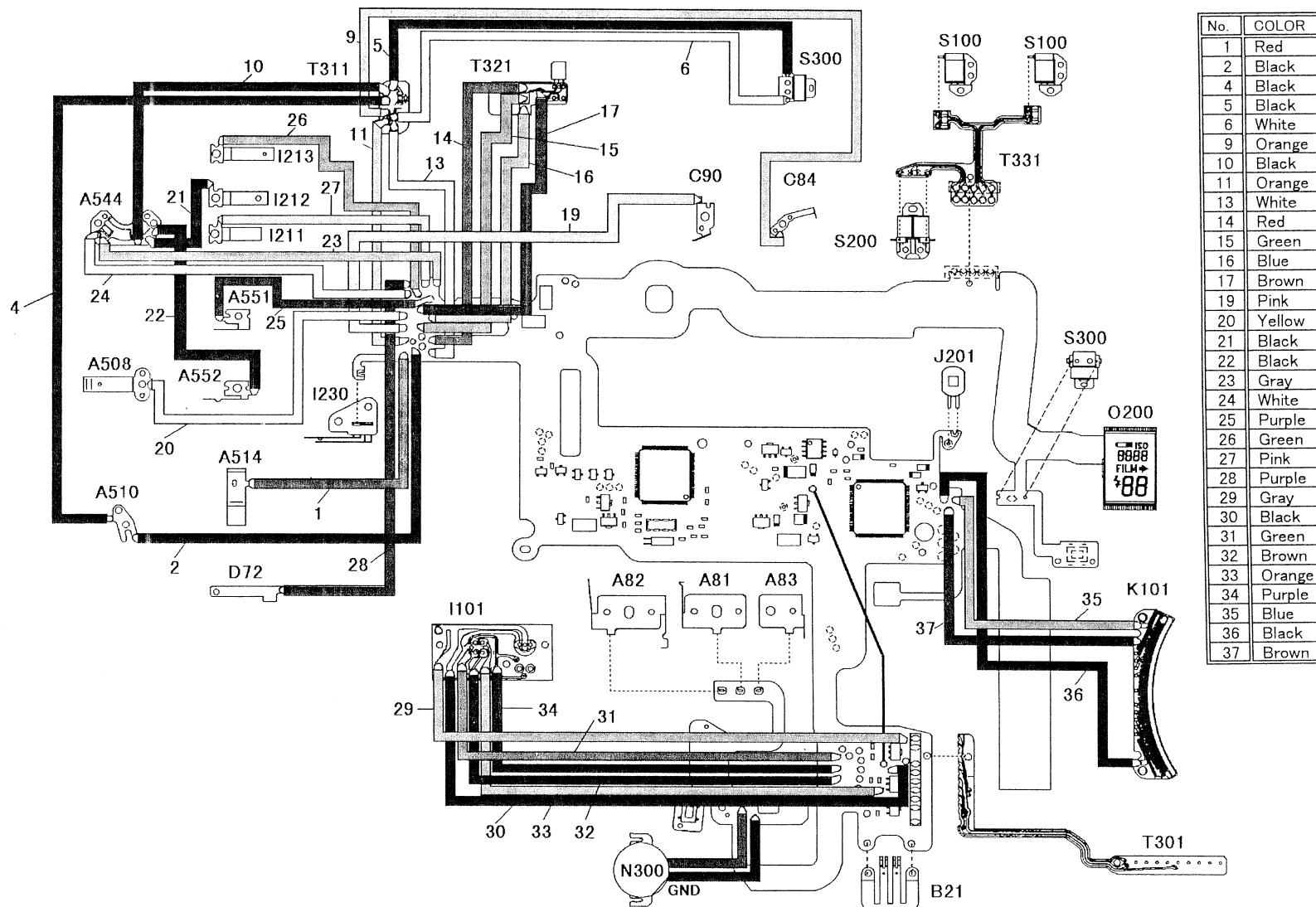

**Product No.27340**  
**PENTAX 67II**

Fig. 7



# LIST OF SERVICE PARTS

Product No.27340

PENTAX 67 II

NOTE: 1.The parts with numbers starting "0-" are assembled parts.  
2.Only available parts are listed below.

\* Q=Quantity A=Address(Fig./Vertical: A-H /Horizontal: 1-6)

Parts No.	Description	Q	Interchangeability	NM No.	A
0 - A2	Spool shaft assy. (A2,A69)	2	23401-0-A107-01		2E3
0 - A3	Spool handle assy. (A3,A4,A71x2)	2	23401-0-A98-02		2G3
A5 - 00A	Spool shaft adjust washer A	2	23401-A140-00A		2F4
A5 - 00B	Spool shaft adjust washer B		23401-A140-00B		2F4
A5 - 00C	Spool shaft adjust washer C		23401-A140-00C		2F4
A5 - 00D	Spool shaft adjust washer D				2F4
A5 - 00E	Spool shaft adjust washer E				2F4
A6	Handle screw	2			2G3
A11	Bottom light seal plate	2	23401-A126		2E2,2E3
A12	M-BOX fixing screw	1			1F4
A13	Film start mark	1			2E1
A14	Scratch prevention sheet	2	23401-A137		1F4
A15	Roller retainer	4			2E1,2F1
A17	Roller spring	4	23401-A46		2E1,2F1
A18	Roller	2	23401-A47		2E1,2E2
A19	Roller collar	4			2E1
A21	Light seal A	1			2E3
A22	Light seal B	1			2D2
A23	Light seal C	1			2D2
A24	Light seal D	2			1D3,1D4
A26	Light seal F	1			2D3
A27	Light seal cloth A	2	23401-A125		2D1,2E4
A29	Light seal G	1			2D3
A31	Retainer screw A	5			1D4 2C2,2G4

Parts No.	Description	Q	Interchangeability	NM No.	A
A32	Retainer screw B	1			1F3
A33	Retainer screw C	6			1E4,1F5 3B3
A34	Retainer screw D	4			1C2,2C2
A35	Retainer screw E	4			2F3
A36	Retainer screw F	1			1D1
A37	Top cover retainer screw	1	27460-X30		1G1
A38	Back-tension retainer screw	1	26900-A408		2C2
0 - A41	Back cover key rest assy. (A40,A41,A42,A43,A44, TY-CSS1.7x3.0 x2)				1B1,1G5
A40	Back cover key rest	1			1C1
A41	Back cover key	1			1B1
A42	Key cover	1			1C2
A43	Back cover key knob	1			1C1
A44	Back cover key spring	1			1C1
0 - A48	Film contact roller A assy. (A46,A48,A50 x2,A51,A52,A53 x2,A54, A55,A56,A58,A59,A60,LW13)	1			2E4
0 - A49	Film contact roller B assy. (A47,A49,A50 x2,A51,A53 x2,A54,A55, A57,A58,A59,A60,A73,LW13)	1			2D2
0 - A61	Counter roller assy. (A61,C101)	1			2E2
A62	Roller shaft metal	1			2E3
A64	Guide roller	1	23401-A64-01		2D2
A65	Protection plate	2	23401-A65		2G3
A66	Spool shaft holder	2			2F3
A67	Metal nut	2	23401-A67-02		2G3
A68	Guide roller shaft	3	23401-A68		2D2,2D3 2E3
A70	Spool handle spring	2	23401-A70-01		2G3
A72	Spool click spring	2	23401-A72-01		2F3

Parts No.	Description	Q	Interchangeability	NM No.	A
A74	Spool retainer spring	2	23401-A74-01		2E3
0 - A75	Back-tension shaft assy. (A8,A9,A10,A75,A76,A77,A78,A79)	1			2D2
A80	Back cover SW pedestal	1			3B5
A81	Back cover SW contact A	1			3B5
A82	Back cover SW contact B	1			3A5
A83	Back cover SW contact C	1			3A5
A84	Back cover SW insulation plate	2			3A5
A85	Switching pin	1			1F4
A86 - 00A	Key box adjust washer A	1	23401-A86-00A		1G4
A86 - 00B	Key box adjust washer B		23401-A86-00B		1G4
A87	PVC holder	1			3B5
A88	Accessory lug	2			1F3,1G3
0 - A101	Left side cover assy. (A101,A103,A104,I101,I102,I103,I105 x5, I106,I107,I108,I109,I110 x2,I111,LW7 x2, TY-CNL-D1.7x3.0 x2)				1G4,1D4
A101	Left side cover	1			1D5
A102	Left side covering	1			1E4
A103	Penta prism lock button L	1			1C5
A104	Penta prism lock spring L	1			1C5
0 - A111	Right side cover assy. (A111,A113,A114,A115,A116,A117, A118,A119,TY-CNL-E1.7x3.0, TY-CNL-F1.7x3.0,GS2.5)				1B3,1D3
A111	Right side cover	1			1C2
A112	Right side cover covering	1			1D2
A113	Penta prism lock button R	1			1B2
A114	Penta prism lock spring R	1			1B2
A115	Mirror-up lever	1			1C2
A116	Mirror-up brush	1			1C3
A117	Mirror-up lever spring	1			1C2

Parts No.	Description	Q	Interchangeability	NM No.	A
A118	PS. TIME lever	1			1C2
A119	PS. TIME sliding plate	1			1C3
A120	Bottom cover plate	1			1D2
A121	Bottom cover	1			1D1
A122	Bottom cover covering	1			1D1
A123	Country seal	1	26500-A119-0100J		1D2
A124	Number seal	1	27251-A404		1D2
A131	Front cover, left	1			1F3
A132	Covering rubber, left	1			1G3
0 - A201	Back cover assy. (A201,A203,A204,A207,A208,A209, A210,A211,A213,A214 x2,A216 x2, A212,A217 x4,A218,A219,A221,A222, A223,A224,A226,A228 x2,A229 x4, A232,A234, A235,A236,A237,A238 x4, A239,A240 x6,A241,A242,A243 x2, A224 x2,A245 x3,A246, TY-CNS1.7x3.0 x5, LW10 x2)	1			2A4,2C5
A208	Back cover light seal I	2			2B3
A209	Rear plate light seal cushion	1	23401-A169		2B5
A210	Back cover light seal D	1			2B3
A226	Memo holder	1			2A5
0 - A227	Pressure plate assy. (A220,A227)	1			2D4
A242	Film roller shaft	1	23401-A158		2B4
A243	Film roller	2	23401-A159		2A4,2B4
A245	Film anti-friction roller	3	23401-A165		2B4
0 - A301	Top cover assy., right (A301,A302,A303,A304,A305,A306,A307, A308,A309,A310,A311,A312,A313 x2, A314,A315 x3,A316,TY-CNL-D1.4x2.5, TY-CNL-E1.7x3.0,TY-CNL-F1.7x3.0, TY-CNS1.7x3.0 x2)				1A3,1E3
A301	Top cover, right	1			1A3
A302	LCD window	1			1A3

Parts No.	Description	Q	Interchangeability	NM No.	A
A303	Main dial	1			1B2
A304	Dial plate	1			1B2
A305	Main dial click plate	1			1B2
A306	Release pin retainer plate	1			1B3
A307	Main SW brush	1			1B2
A308	Main dial ball spring	1			1B3
A309	Release button	1	27350-A321		1A2
A310	Release pin	1	27350-A322		1A2
A311	M.E. operation lever	1			1A3
A312	M.E. lever	1			1A3
A313	Main dial retainer screw	2			1B2
A314	M.E. lever spring	1			1B3
A321	Rear cover	1			2C3
A322	Rear cover spacer	1			2D2
A324	AE button retainer spring	1			2C3
0 - A351	Top cover assy.,left (A351,A352,A353,A354,A355,A356, A357,A358,A360,A361x2,A363,A364, A368,A369,A371,A372,A373,A374, A378,A379 x2,I221,BO2.0 x2, TY-CNL-D1.7x3.0 x2, TY-CNL-D1.7x3.5 x2, TY-CNL-G1.7x3.0)				1A4,1F5
A351	Top cover,left	1			1B5
A352	Name plate	1			1B4
A353	TV dial	1			1A5
A354	TV dial rubber	1			1A4
A355	TV dial stopper release button	1			1A4
A356	TV dial stopper release button spring	1			1A4
0 - A357	TV dial stopper spring assy. (A357,A378,A379 x2)	1			1B5
A358	TV dial stopper plate	1			1A4

Parts No.	Description	Q	Interchangeability	NM No.	A
A360	TV dial click plate	1			1A5
A361	TV dial click spring	2			1A4,1B5
A363	TV dial support plate	1			1C4
A364	TV dial code plate	1			1C4
A368	AE / ISO button	2			2C3
A369	AE / ISO button retainer spring	1			1B4
A371	U / D lever	1			1B4
A372	U / D slide plate	1			1A4
A373	U / D lever spring	1			1A4
A374	U / D brush	1			1B4
A401	Under cover, right	1			2F4
A451	Under cover, left	1			2F2
0 - A501	Grip assy. (A501,A511 x4)	1			1F1
0 - A502	Grip base plate assy. (A502,A531,A532,A533 x2,A534 x2, A538 x2)	1			1E2
A503	Battery cover screw	1			1F2
0 - A504	Battery cover assy. (A504,A505,A506,A507)	1			2F4
A508	Reset SW contact A	1			1E3
A509	Reset SW contact B	1			1F2
A510	Battery contact spring (-)	1			1G2
A512	Grip rubber	1			1F1
A513	Grip hole cover	1			1F1
A514	Battery contact spring	1			1F2
A515	Grip retainer screw	2			1F1
A519	Reset SW pin	1			1F2
A522	DT for grip rubber	1			1F1,1G3
A535	Battery case lever spring hook	1			1E2

Parts No.	Description	Q	Interchangeability	NM No.	A
A536	Battery case lever spring A	1			1F2
A537	Battery case lever spring B	1			1E2
A541	Release SW stand	1			1E2
A542	Main SW pedestal	1			1E1
A543	Release contact holder plate	1	27350-A515		1E1
A544	Main SW board	1			1E1
A551	M.E. SW fixed contact piece	1			1E2
A552	M.E. SW moving contact piece	1			1E2
A553	M.E. SW insulation plate	1			1E2
B2	Bayonet seat	1			3G2
B3	Bayonet spring	3	23401-B3		3G2
B4	Bayonet stopper	1	23401-B4		3G2
B5	Light seal string	1			3E1
B8	Mirror housing frame	1	23401-B63-01		4B4
0 - B11	View finder lock plate assy. (B11,B12 x2)	2	23401-0-B73-01		3C3 3C4
0 - B14	Lock release pin assy. (B13, B14)	2			3C2 3D4
B21	Focus screen SW contact	1			3F5
B22	Focus screen SW pin	2			3D4
B25	Electrostatic protection tape	1			3C4
0 - B32	Tripod plate assy. (B31,B32)	1			3E3
B33	Lock-pin lever	1			3E5
B34	Lock-pin	1	23401-B34-02		3E3
B35	Lock-pin lever retainer screw	2	23401-B35-01		3E5
0 - B36	Lock-pin guide assy. (B36,B37,B40)	1			3D4

Parts No.	Description	Q	Interchangeability	NM No.	A
B38	Lock spring	1	23401-B53		3E4
B39	AM SW pin	1	23401-B62		3E4
B41	AM SW collar	1			3D4
B42	AM SW	1			3E4
B43	AM SW spring	1			3D4
B44	Black sheet	1	27020-A44		3G4
B46	Mirror sheet cushion	1			3E3
B47	Light seal curtain	1	23401-B95		4B4
B50	Light seal cushion	1			3C2
B52	Diaphragm actuator light seal A	1	23401-B100		3D2
B53	Diaphragm actuator light seal B	1	23401-B101-01		3D2
B54	Lock-pin lever covering	1			3E5
B55	Bayonet seat covering A	1			3F1
B56	Bayonet seat covering B	1			3F1
B57	Bayonet seat covering C	1			3G1
B58	Bayonet seat covering D	1			3G1
0 - C1	Shutter charge main gear assy. (C1,C22,C29,C41,C42,C69,C70,C71, C72,C93)	1			5B4
C2	Mirror charge 1st gear	1			5D3
0 - C3	Mirror coupler rod assy. (C3,C4,C12,W85 t=0.2,BO1.0 x8, CE-3,LW13)	1			5E2
C5	Mirror charge 3rd gear	1			5F2
0 - C6	Mirror charge 4th gear assy. (C6,C12,W85 t=0.2,BO1.0 x8,LW13)	1			5F2
0 - C7	Mirror charge 5th gear assy. (C7,C8,C12 x2,W85 t=0.2,BO1.0 x16 LW10 x2,LW13)	1			5F4
C9	Mirror charge install plate A	1			5F3



Parts No.	Description	Q	Interchangeability	NM No.	A
C10	Mirror charge install plate B	1			5G3
C11	Ball receptacle A	1			5F2
C12	Ball receptacle B	1			5F3
C15	Ball bearing	1			5E3
0 - C20	Winding stopper assy. (C17,C20,C21,C65 x2,C77)	1			5E2
0 - C25	Duality prevention coupler lever assy. (C25,C58)	1			5B5
0 - C26	Winding lock interval lever B assy. (C26,C79)	1			5D4
C27 - 01A	Winding stopper A	1	23401-C27-01A		5D5
C27 - 01E	Winding stopper E				5D5
C27 - 01F	Winding stopper F				5D5
C27 - 01G	Winding stopper G				5D5
0 - C28	Winding ratchet assy. (C28,C80,C82)	1			5C4
0 - C30	Spool shaft plate assy. (C30,C31,C32,C45,C46,C47,C48,C49, C66,C78,C81,C95,CNS1.4x1.5)	1			5D3
C33	Winding support plate	1			5C3
0 - C34	Winding shaft plate assy. (C28,C34,C54,C55 x4,C67,C68 x2, C74 x2,C75,C76,C80,C82,C97,E100, CNL-D1.4x3.0,W65 t=0.05)	1			5C3
C35	Winding lever click spring	1			5B3
C37	Winding lever click SW spacer A	1			5B3
C39	Winding SW insulation washer A	1			5B2
C40	Click spring support plate	1			5C3
C43	Winding 2nd gear	1	23401-C43-02		5D3
C44	Winding 3rd gear	1	23401-C44-02		5D4
C50	Winding lever cover	1			5B1
C51	Winding lever	1			5B1
C52	Winding shaft receptacle plate	1			5B4
C53	Winding lever spring	1	23401-C58		5B3

Parts No.	Description	Q	Interchangeability	NM No.	A
C56	DT for winding lever cover	1			5B1
C57	Duality prevention coupler lever shaft	1	23401-C73		5C4
C60	Winding SW stand	1			5B4
C73	Winding lever SW stand	1			5C2
C83	Winding shaft guide screw	1			5B3
C84	Winding halfway SW	1			5B4
C85	Halfway SW insulation plate	1			5C4
C86	M.E. sine lever	1			5C1
C87	M.E. stopper plate	1			5D2
C88	M.E. stopper spring	1			5D2
C89	Winding lever click SW	1			5C2
C90	Winding lever click fixed contact	1			5B2
C91	Winding stopper spring	1			5E2
C92	Winding lock lever spring	1			5D4
C94	Spool reversal stopper spring	1	23401-C117-01		5D3
C96	Winding 2nd gear spring	1	23401-C119		5C3
C97	Ratchet spring	1			5C4
C98	Duality prevention coupler lever spring	1	23401-C125		5C5
C100	Winding lever spacer	1			5C1
0 - C102	Pulsar base plate assy. (C102,C103 x2,C104,C106 x2,C107) C108,T321,T322,TY-CNL-B1.4x2.0)	1			5G4
C105	Counter roller gear	1			5F4

Parts No.	Description	Q	Interchangeability	NM No.	A
0 - D1	Mirror base plate assy. (D1,D2,D4 x4,D6,D8,D9,D10,D11,D14, D15,D16 x3,D17,D19,D22,D24,D26,D27, D28,D29,D30,D31,D32,D33,D34,D36, D39,D40,D41,D42 x2,D43,D44,D45,D46, D47,D48,D49,D50,D51,D53,D123,D151, CSS1.4x1.6 x3,CNH-G2.0x3.5 CNL-G1.7x3.5,LW13,LW15,BO1.0 x9, W9 t=0.05(adj.),W9 t=0.25(adj.))	1			4E3
D2	Support base plate	1			4E2
D4	Base plate screw B	2	25000-B4		4E2
D6	Ball receptacle washer A	1			4G2
0 - D11	Mirror actuator arm assy. (D10,D11,D12)	1			4D4
0 - D14	Center gear assy. (D14,D15,D16 x3)	1			4E2
D17	Mirror operation plate	1			4E1
D19	Flip-up spiral spring	1	23401-D19		4E2
D23	Mg plate retainer screw	1			4F4
D24	Restoring gear	1			4F2
D26	Mirror restoring spiral spring shaft	1			4F2
D27	Restoring spiral spring	1	23401-D27		4F2
D31	Swing lever spring	1			4F3
0 - D32	Diaphragm charge gear assy. (D32,D33)	1			4F2
D37	FPC install plate	1			4G5
D39	Diaphragm interval gear shaft	1			4D4
0 - D40	Mirror charge double gear assy. (D40,D41,D42)	1			4F2
0 - D43 - 00A	Mirror charge interval gear A assy. (D42,D43-00A)	1			4G2
0 - D43 - 00B	Mirror charge interval gear B assy. (D42,D43-00B)				4G2
0 - D43 - 00C	Mirror charge interval gear C assy. (D42,D43-00C)				4G2
0 - D43 - 00D	Mirror charge interval gear D assy. (D42,D43-00D)				4G2

Parts No.	Description	Q	Interchangeability	NM No.	A
D44	Release spring	1			4F4
D48	Mirror stopper hook	1			4F3
D49	Diaphragm stopper hook collar	1			4F3
D50	Diaphragm stopper hook	1			4F3
D52	Shutter curtain stopper hook collar	1			4D2
D54	2nd curtain release spring	1			4D2
0 - D55	2nd curtain operation lever assy. (D55,D60,D76,S102)	1			4D3
D56	1st curtain release spring	1			4D2
0 - D57	1st curtain lever assy. (D57,D60,D75,S102)	1			4D2
D58	Joint spring	1			4F3
D59	Magnet plate	1			4F5
D67	Mirror stopper support spring	1			4A3
D68	Support spring retainer collar	1			4A3
D72	Wind-end SW fixed contact	1			4E2
D73	Wind-end SW moving contact	1			4E2
D74	Protection tube	1			4E2
D77	2nd shutter magnet adjusting plate	1			4F5
D78	2nd shutter magnet adjusting screw	1			4F4
D79	1st shutter magnet retainer screw	1			4F4
D123	Light seal cover	1			4D4
D124	Mirror arm pedestal spring	2	23401-D124		4B3,4C4
0 - D125	Mirror sheet assy. (D125,D128,D129,D139 x4,D141 x2, D142,D145 x6,D153,)	1			4C4
0 - D126	Arm pedestal assy. (D126,D143 x4)	2			4A2,4B5
D127	Spring hook screw	1	26300-A406		4A3
D130	Light seal tape	2			4A2
D132	Damper plate L	1			4C2

Parts No.	Description	Q	Interchangeability	NM No.	A
D133	Damper plate R	1			4C3
0 - D134	Mirror arm assy. (D134,D139,D157)	4	23401-0-D134		4B2,4C4
D138	Support spring	1	23401-D138-01		4B2
D147	Arm pedestal retainer screw	5	24000-E158		4A2,4C5 5F2
D148	Damper plate adjusting screw	2			4B2
D149	Damper plate adjusting nut	3	23401-B83		4C3
D151	Anti-reflection sheet A	1	23401-D151		4D4
D152	Anti-reflection sheet B	1	23401-D152-01		4A3
D153	Anti-reflection sheet C	1	23401-D153-01		4A4
D154	Anti-reflection sheet D	2	23401-D154-01		4B3,4C4
D155	Anti-reflection sheet E	6	23401-D155		4B2,4C4
D159	Anti-reflection sheet F	1	23401-D159		4B3
A0 - E1 - 00A	Damper mech. A assy. (E1,E2,E3 x2,E4,E5 x2,E6-00A x2, E7 x2,E8,E9,E10,E11 x2,E12,E13 x2, E15 x6,E16 x2,E17 x2,E18 x2, E19-01A(-01B) x2,E20 x2,E21 x2, E22 x2,E23 x2,E24 x2,E25,E26,E27, E28,E29,E30,E103,W2 t=0.15 x4, W3(adj)x4,W17(adj)x2,W17 t=0.1 x2, W52 t=0.3 x4,W54 t=0.4 x4, LW10 x4,LW13 x4,LWG6 x2)	1	23401-A0-E1-00A		6F2
A0 - E1 - 00B	Damper mech. B assy.		23401-A0-E1-00B		6F2
A0 - E1 - 00C	Damper mech. C assy. (E1,E2,E3 x2,E4,E5 x2,E6-00A,E6-00B, E7 x2,E8,E9,E10,E11 x2,E12,E13 x2, E15 x6,E16 x2,E17 x2,E18 x2, E19-01A(-01B) x2,E20 x2,E21 x2, E22 x2,E23 x2,E24 x2,E25,E26,E27, E28,E29,E30,E103,W2 t=0.15 x4, W3(adj)x4,W17(adj)x2,W17 t=0.1 x2, W52 t=0.3 x4,W54 t=0.4 x4, LW10 x4,LW13 x4,LWG6 x2)		23401-A0-E1-00C		6F2

Parts No.	Description	Q	Interchangeability	NM No.	A
A0 - E1 - 00D	Damper mech. D assy. (E1,E2,E3 x2,E4,E5 x2,E6-00B x2, E7 x2,E8,E9,E10,E11 x2,E12,E13 x2, E15 x6,E16 x2,E17 x2,E18 x2, E19-01A(-01B) x2,E20 x2,E21 x2, E22 x2,E23 x2,E24 x2,E28,E30, W2 t=0.15 x4,W3(adj)x4 W17(adj)x2,W17 t=0.1 x2, W52 t=0.3 x4,W54 t=0.4 x4, LW10 x4,LW13 x4,LWG6 x2)		23401-A0-E1-00D		6F2
0 - E25	X SW lever assy. (E25,E26,E27,E30)	1			6F3
E29	X SW lever spring	1			6F3
0 - E34	2nd curtain pinion shaft assy. (E34,E38)	1	23401-0-E34-02		6A2
0 - E35	1st curtain pinion shaft assy. (E35,E39)	1			6B2
0 - E41	Curtain pipe assy. (E41,E46,E47,E57)	1			6D2
0 - E42	1st curtain pipe assy. (E37,E40,E42,E44,E45,E62, W8 t=0.2,LW20)	1			6E5
0 - E43	2nd curtain pipe assy. (E36,E40,E41,E43,E44,E45,E46,E47,E57, E62,W8 t=0.2,LW20)	1			6E4
E48	1st curtain shaft A	1	23401-E48-03		6C1
0 - E49	1st curtain shaft B assy. (E49,E57)	1			6D1
E50	Curtain roller A	2	23401-E50		6E5 6F5
E51	Curtain roller B	2	23401-E51-02		6C2,6D2
E52	Weight	1	23401-E52		6D1
E53	Bonding Tape for shutter curtain	2			6B2,6C4
E54	Bonding Tape for shutter ribbon	4			6A2,6C4
E58	2nd spring shaft collar	1	23401-E58		6E4
0 - E59	2ND SHUTTER CURTAIN ASSY. (E55 x2,E59,E60 x2,E61)	1	23401-1-E59-01		6B3

Parts No.	Description	Q	Interchangeability	NM No.	A
A0 - E59	2nd shutter curtain assy. (E53,E54 x2,E55 x2,E59,E60 x2,E61 E36,E40,E41,E43,E44,E45,E46,E47,E57, E62,W8 t=0.2/0.5,LW20)				6A4
0 - E63	1ST SHUTTER CURTAIN ASSY. (E55 x2,E60 x2,E61,E63)	1	23401-1-E63		6B4
A0 - E63	1st shutter curtain assy. (E37,E40,E42,E44,E45,E53,E54 x2, E55 x2,E60 x2,E61,E62,E63, W8 t=0.2,LW20)				6A5
E65	Curtain shaft plate spring	1			6D4
E66	Curtain pipe retainer screw	4	23401-E66		6D1 6D2,6E1
0 - E67	Shaft plate A assy. (E67,E70,E71,E72,E73,E96)	1			6C2
E68	Shaft plate B	1			6E1
E69	Shaft plate C	1	23401-E69-01		6F4
0 - E74	1st selector gear assy. (E74,E75,E77,E94 x2,E104,E106)	1			6B1
E78	Selector shaft collar	1			6B1
E79	Selector shaft nut	1			6B1
0 - E80 - 00A	Curtain charge gear A assy. (E80-00A,E81)	1			6B1
0 - E80 - 00B	Curtain charge gear B assy. (E80-00B,E81)				6B1
0 - E80 - 00C	Curtain charge gear C assy. (E80-00B,E81)				6B1
E82	Curtain checker lever	2	23401-E82		6B1,6C1
E83	Curtain shaft wheel	2			6D4
E84	Checker lever collar	2	23401-E84		6B1,6C1
E85	Checker lever retainer screw	1			6B1
E86	Checker lever spring	2	23401-E86		6B1,6C1
0 - E87	Mirror stopper release lever assy. (E87,E105)	1			6C1
E88	M.E. restrict plate	1			6B1

Parts No.	Description	Q	Interchangeability	NM No.	A
E89	M.E. restrict plate collar	1			6B1
E90	M.E. restrict spring	1			6B1
0 - E91	Duality prevention lever assy. (C65 x2,E91,E92,E98,E107)	1			6B2
E93	Shaft plate retainer screw	11	23401-E93-01		4D3,4F3 5C3,6C2 6D5,6E1 6F3,6F5
E95	Duality prevention lever spring	1			6C2
E97	Shaft plate A retainer screw	1	23401-E97-01		6C1
0 - E99	2nd selector gear assy. (E76,E94 x2,E99,E102,E104,E106)	1			6B1
E101	LCD install plate	1			6F1
E109	Winding magnet install plate	1			6C3
E110	Curtain shaft pedestal	1			6D5
0 - I101	X-synchronize board assy. (I101,I105 x5,I107,I108,I109, I110 x2,I111,LW7 x2)	1			1C4
I102	5P socket pedestal	1			1D4
I103	X SW insulator A	1			1D4
I106	X-synchronize pedestal	1			1C4
I211	Release contact A	1	27350-I301		1E1
I212	Release contact B	1	27350-I302		1E1
I213	Release contact C	1	27350-I303		1E1
I214	Release SW insulating plate	2	27350-I304		1E1
I221	TV brush	1	27350-I500		1C5
I230	X SW	1	23401-0-E29-01		6F3
0 - J201	Light sensor assy. (J201,J202,J203)	1			3F3



Parts No.	Description	Q	Interchangeability	NM No.	A
K101	Resistor	1			3D1
0-K102	Diaphragm coupler ring assy. (K102,K103,K106 x2,K107,K108, K110,K113 x2)	1			3D2
K104	Slider spring hook B	1			3D2
K105	Slider cover	2			3D1
K109	Slider spring	1	27350-K114		3D2
K111-00A	Slider roller A	1			3E3
K111-00B	Slider roller B				3E3
K111-00C	Slider roller C				3E3
K112	Slider roller shaft	1			3E3
K114	Resistor retainer screw	2			3D2
K115	Resistor spacer	1			3E2
K116	Insulating tape	1			3E3
L1	Main mirror	1			4C1
L2	Focus screen	1			3D1
L4	Protection glass	1	23401-L4		3C1
M1	Focus screen frame	1			3B1
M2	Focus screen frame retainer	4			3B1
M3	Focus screen adjusting plate	1			3B3
M5	Focus screen retainer	2			3C3
M6	Focus screen fixing spring	1			2C3
M9	Penta regulation rubber A	2			3B3
M10	Penta regulation rubber B	2			2C2
M11	Viewfinder positioning pin	2			3C3
M12	Focus screen retainer spring	2			3C3

Parts No.	Description	Q	Interchangeability	NM No.	A
N300	PVC	1	26900-N300		3C5
O201	LCD	1			6E1
O202	LCD frame	1			6F1
O203	LCD retainer	1			6E1
O204	Conductive rubber	2			6E1
S100	Shutter magnet	2	26400-S101		4F4
S200	Release magnet	1			4G4
S300	Winding magnet	2			5E4 6C2
T1	Main P.C.Board install plate A	1			3G3
T2	Main P.C.Board install plate B	1			3G4
T3	FPC retainer screw	1			3G4
T13	Tape C	1			3F4
T18	Main P.C.board insulation tape	1			1D2
T100	Main P.C.board	1			3F3
0 - T301	Viewfinder contact board assy. (M7,M8 x9,T301)	1			3B2
0 - T311	Winding MG relay P.C.board assy. (T310,T312)	1			1F3
0 - T331	Shutter magnet relay P.C.board (T331,T332,T333 x2)	1			4G3
A561-50	Strap install screw	1			-
A562-50	Strap spacer	1			-

**PENTAX®**

# Service Manual

ENGLISH

## AE PENTA PRISM FINDER 67 II

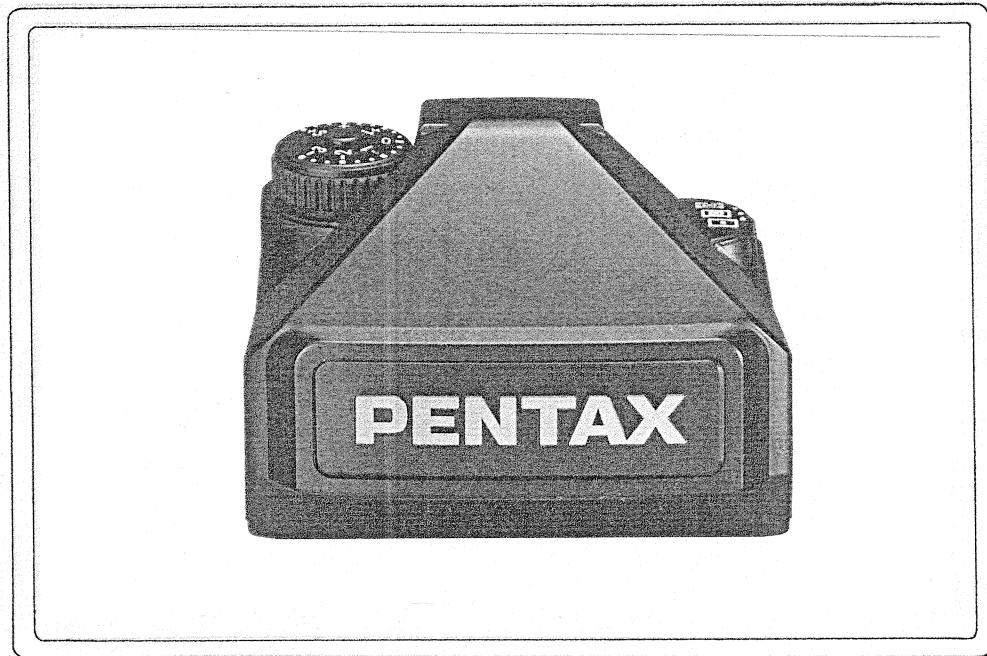

**Product No.71081**

# Table of contents

	Page
1. Disassembly and Assembly	2-4
2. Adjustment of photo sensor position	5
3. Adjustment LCD position	6
4. Adjustment and check with computer program	6
5. List of jigs, tools and testers	7
6. Technical information : Program software flow chart	8
Technical information : Circuit diagram (T200)	9

# 1. Disassembly and Assembly

Disassembly and assembly should be carried out with reference to the following Figs. 1 to 12.

**Note:** Eyepiece shutter should be handled in an OPEN STATUS.

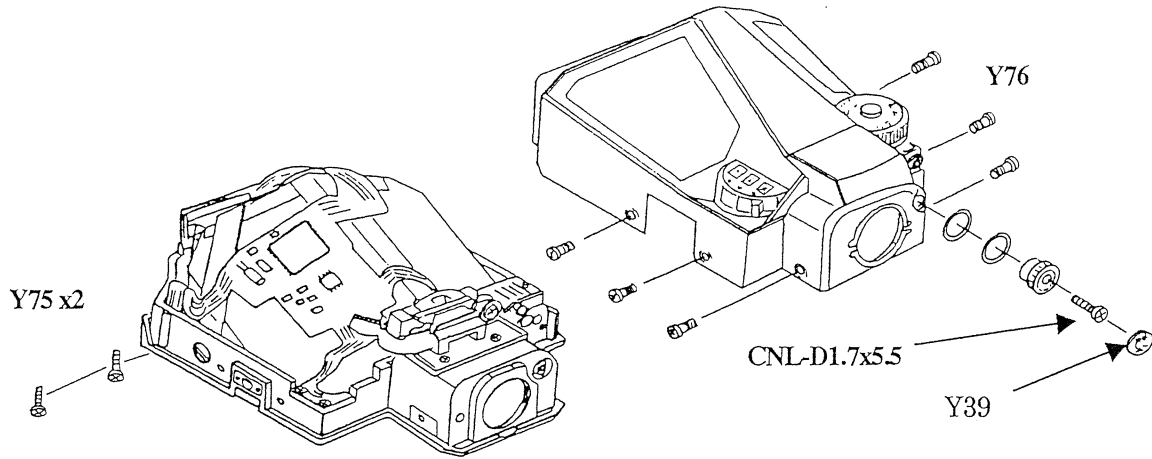

Fig. 1

**Note :** When removing Diaopter adjustment dial retainer screw (CNL-D1.7x5.5), turn the Diopter adjustment ring screw towards ( - ) side and loosen CNL-D1.7x 5.5 screw.

**Note:** Y39 affixing position

After turning the Diopter adjustment ring fully in the clockwise direction, turn it counterclockwise 180 degrees. Affix Y39 so that it positions (+) side comes top.

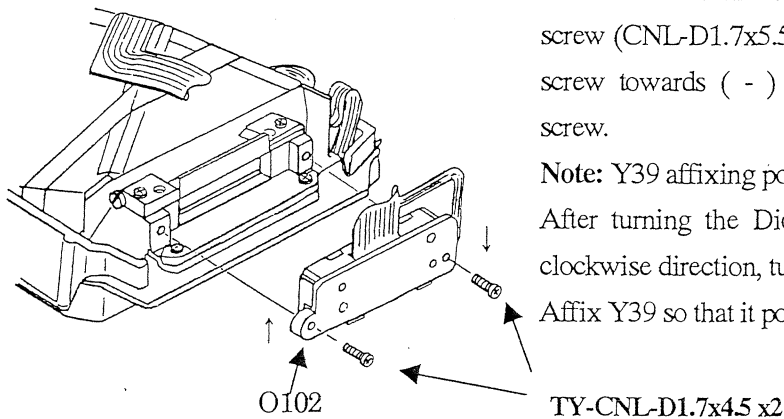

Fig. 2

**Note :** When assembling, push Photo sensor part O102 towards ( ↑ ) and ( ↓ ) and tighten two screws.

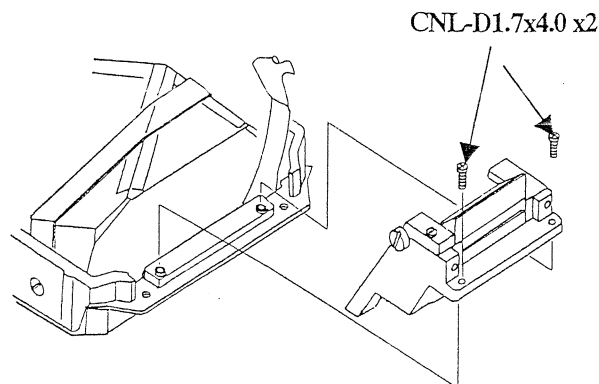

Fig. 3

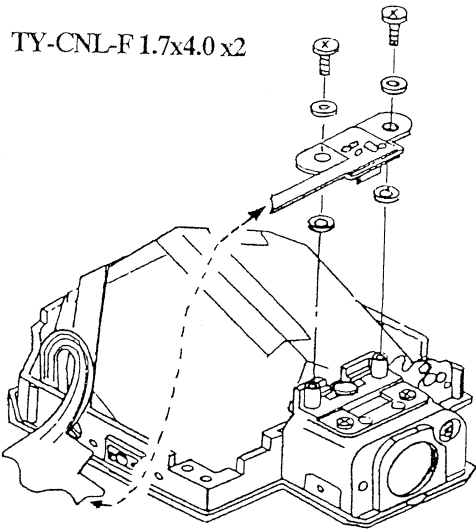

Fig. 4

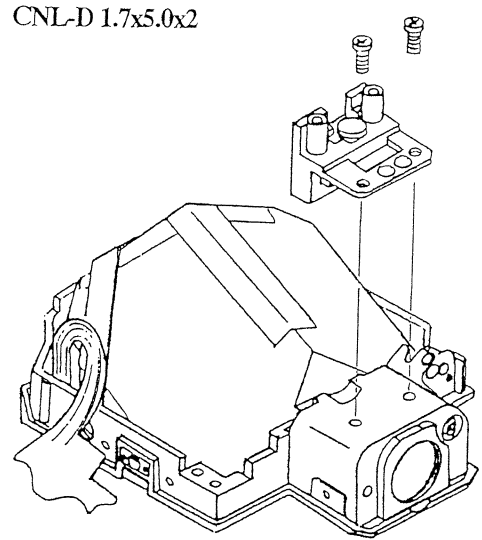

Fig. 5

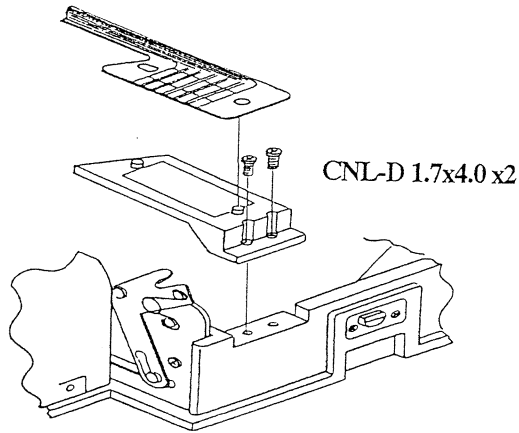

Fig. 6

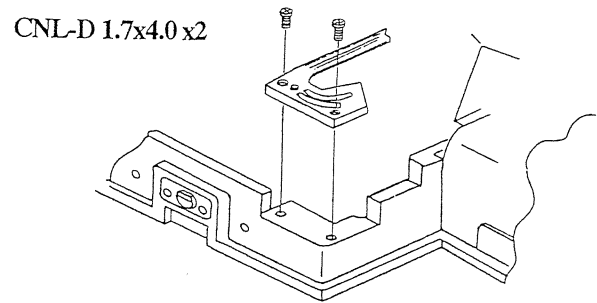

Fig. 7

Note: Do not remove Base in Fig.6 and 7 except when replacing T100.

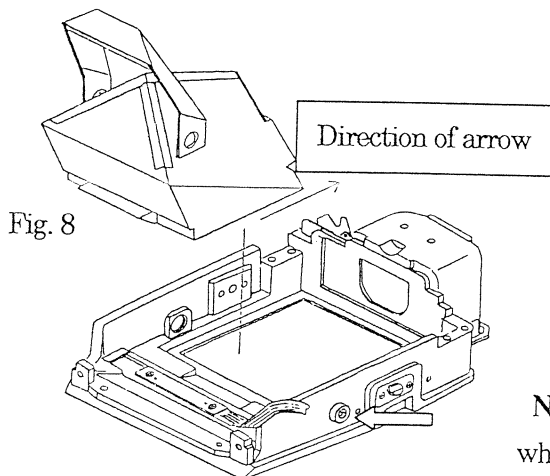

Fig. 8

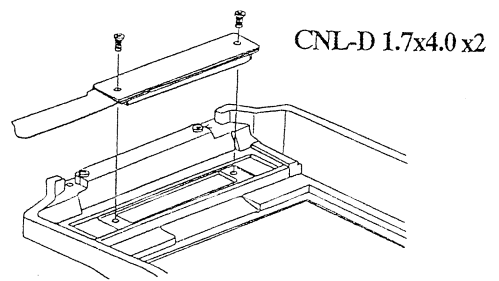
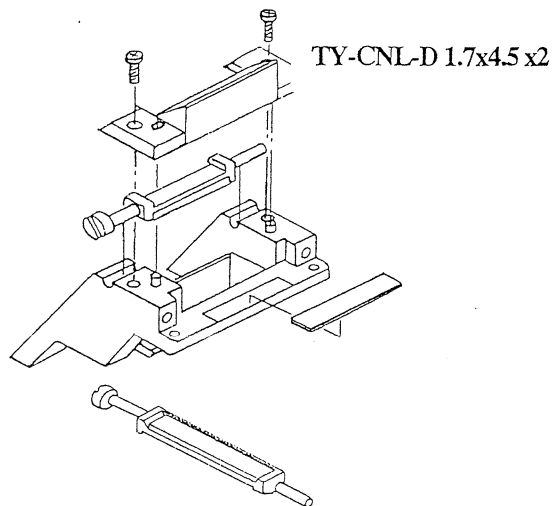
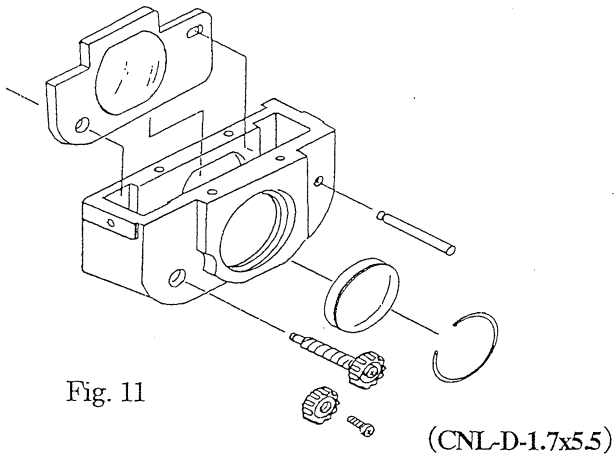
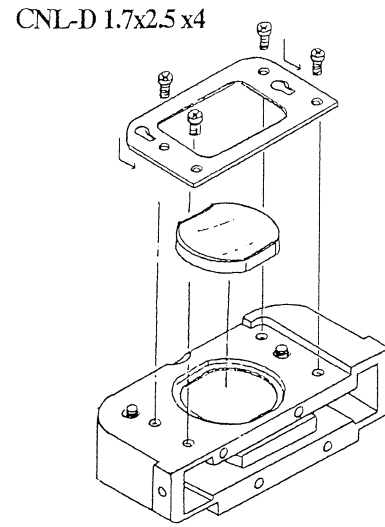
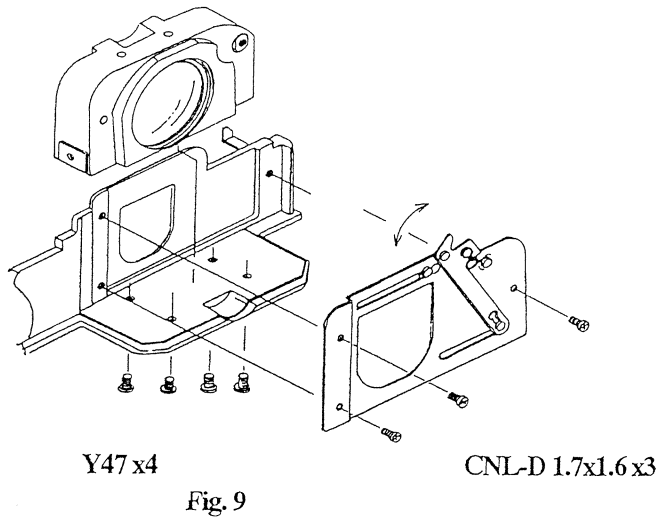

Fig. 9

Note: Push Pentaprism towards Eyepiece ( → ) side when tightening.

Hexagonal screwdriver 2mm used



## 2. Adjustment of photo sensor position

Note: Carry out parallax adjustment beforehand when removing Pentaprism.

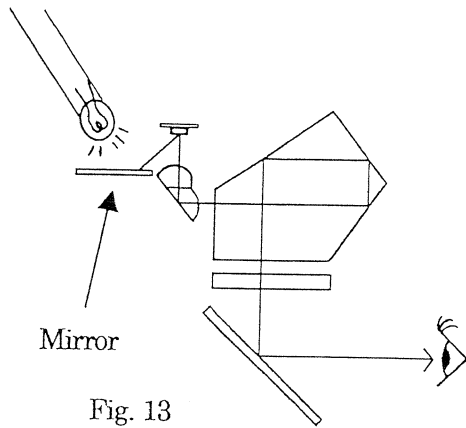

Fig. 13

- (1) Attach the AE Pentaprism Finder 67II to the 67II camera.
- (2) Affix the mirror with reference to Fig. 14.
- (3) Insulate the loupe section against light with black tape.
- (4) Mount the lens (105mm f/2.8) on the camera.
- (5) Apply light of penlight, etc., to mirror and search for position in which the pattern on the light sensor (Fig. 15) can be seen from the lens side..

### (6) Confirmation

Check that the round part at the center of the light sensor is in the position of the microprism and the sensor as a whole is not slanting.

### (7) Adjustment

With reference to Fig. 16, loosen the sensor fixing screws and move to adjust.

- (8) After adjustment, tighten the screws, check the position of light sensor again and apply adhesive.

Remove the mirror affixed in (2).

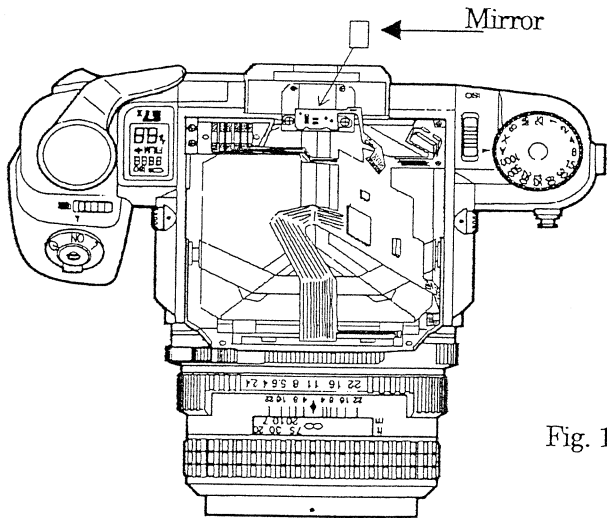

Fig. 14

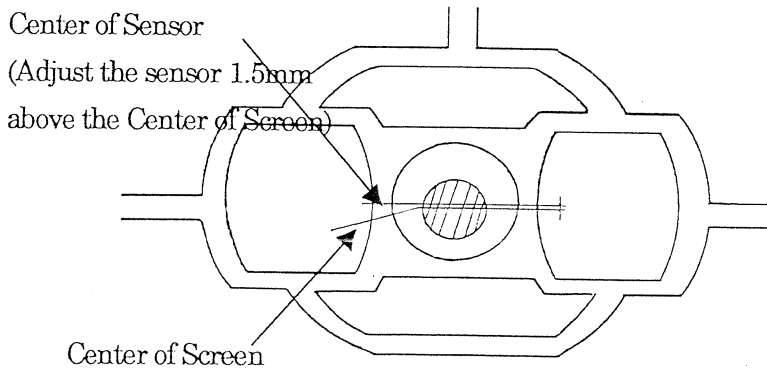

Fig. 15

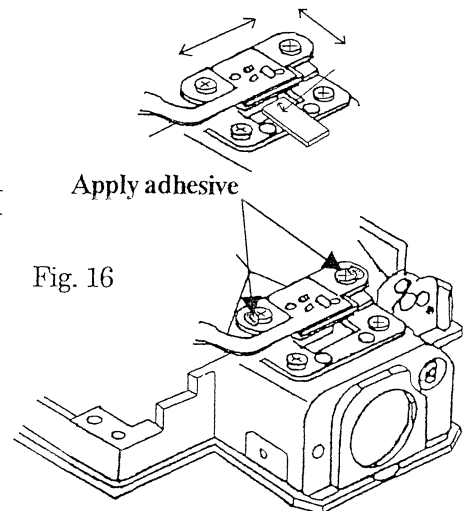

Fig. 16



### 3. LCD position Adjustment

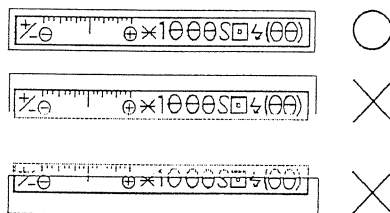
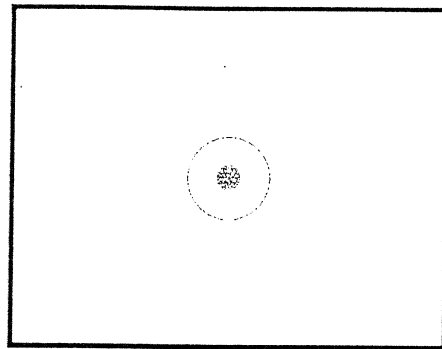

Fig. 17

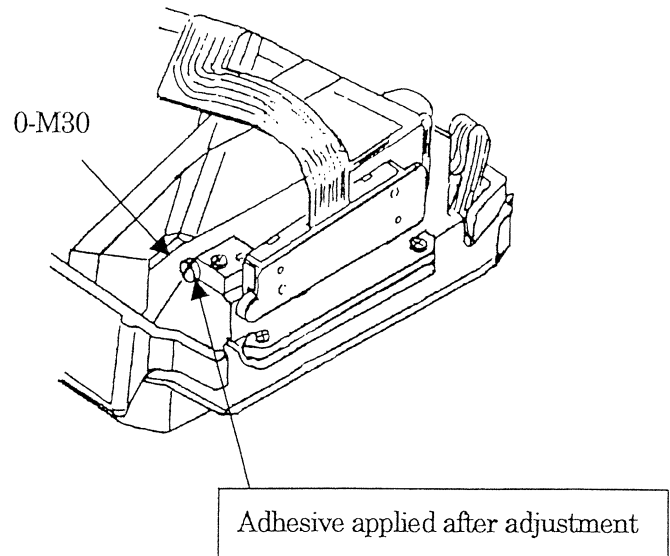

Fig. 18

- (1) Fit AE Pentaprism Finder 67II to the 67II camera.
- (2) Turn power on to the body and half-press shutter button to turn on LCD display in the viewfinder.
- (3) Turn O-M30 with a screwdriver and find out for position in which LCD display is not lost. (Fig. 18)
- (4) After adjustment, apply adhesive and check again after drying.

### 4. Adjustment and check with computer program

- (1) Attach the AE Pentaprism Finder 67II to the 67II camera.
- (2) Connect the 67II camera and the camera multi-adapter A with the camera adapter (95901-M129)
- (3) Turn power on to the camera and adjust and check in accordance with flow chart.

# LIST OF JIGS, TOOLS AND TESTERS

- For exclusive use with 71081 and 27340

	Part no.
1. Program Software for 27340 – 71081)	
(PC98 MID 3.5")	95901 P206
(PC98 MID 5")	95901 P123
(PC/AT MID 3.5")	95901 P243
2. Camera Adapter CAA-27340	95901 K279
- Others	
1. Computer	
2. Shutter Tester EF-8000	
or	
EF-5000	95901 M003-01
3. Connecting Cable (Printer Cable)	
4. Camera multi-adapter	95901 M127
5. AC Adapter for Camera multi-adapter (Output voltage 9-12V/larger than 100mA)	
6. Lens (SMC-Pentax 67 105mm /f2.4) for adjustment	
7. Camera body (67II camera) for adjustment	
8. Hexagonal screwdriver 2mm	

# Program Software Flow Chart

