

GAF[®] SUPER 8 SOUND PROJECTORS

2000 S
3000 S
SEARS 3G9258C

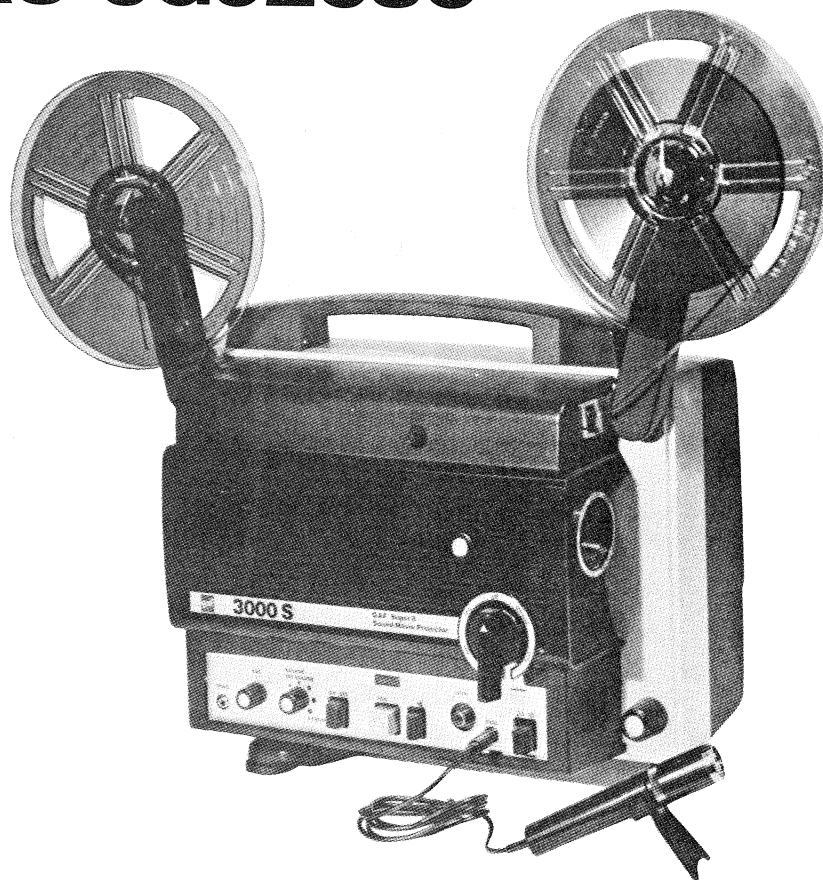

SERVICE MANUAL

GAF Corporation

Consumer Photo Products
Binghamton, N.Y. 13902

Copyright © 1975
GAF Corporation

Manual No. 125-881

Sections

1	INTRODUCTION	1-1
2	SPECIFICATIONS	2-1
2.1	MECHANICAL	2-1
2.2	OPTICAL	2-1
2.3	ELECTRICAL	2-1
3	DISASSEMBLY INSTRUCTIONS	3-1
3.1	DISASSEMBLY PROCEDURE	3-1
3.2	COMPONENT LOCATION ILLUSTRATION	3-3
4	SERVICE INSTRUCTIONS	4-1
4.1	FILM TRANSPORT SYSTEM	4-1
A.	Capstan/Pressure Roller	4-1
B.	Claw/Framer	4-2
C.	Film Path	4-4
D.	Drive Train	4-6
4.2	OPTICAL SYSTEM	4-11
A.	Lamp	4-11
B.	Aperture/Pressure Plate	4-12
C.	Shutter	4-13
D.	Zoom Lens	4-13
4.3	ELECTRICAL SYSTEM	4-14
A.	Motor	4-14
B.	Snap-Action Switch Cluster	4-15
C.	Transformer	4-15
D.	Sound Record/Reproduce System	4-16
5	ELECTRONIC DATA	5-1
5.1	2000 S and 3000 S WIRING DIAGRAM	5-3
5.2	2000 S BLOCK DIAGRAM	5-5
5.3	3000 S BLOCK DIAGRAM	5-7
5.4	2000 S SCHEMATIC	5-9
5.5	3000 S SCHEMATIC	5-11
5.6	2000 S CIRCUIT BOARD	5-13
5.7	3000 S CIRCUIT BOARD	5-15

6	TROUBLESHOOTING	6-1
6.1	CONTROL KNOB MODE CHART	6-1
6.2	INSPECTION PROCEDURE	6-2
6.3	TROUBLESHOOTING CHART	6-5
	A. Projector Completely Inoperative	6-5
	B. Film Transport	6-5
	C. Audio	6-6
	D. Optical	6-7
	E. Electrical	6-7
7	SUPPLEMENTS	7-1

Service information in this manual refers to the GAF[®] 2000 S, 3000 S and SEARS No. 3G9258C Super 8 Sound movie projectors.

NOTE

The GAF 2000 S and SEARS No. 3G9258C projectors are identical except for minor cosmetic changes. For convenience purposes, this Service Manual will indicate only the GAF model. Repair of the SEARS projector is identical to the GAF unit.

Before attempting any adjustment or repair, read this manual thoroughly. Consult the component location illustrations and the troubleshoot-

ing section as the first step in problem diagnosis. Specific illustrations, called out and included in the text, are useful as aids in repairing and/or testing.

This is a Service Manual ONLY. Parts information for these projectors can be found in the current Illustrated Parts Manual for Super 8 Sound Movie Projectors.

Address technical questions to:

GAF Corporation
Consumer Photo Service Center
Emma Street
Binghamton, New York 13902

Supplements to Manual

Before using this manual, it is recommended that the service technician refer to Section 7 for

possible additional information or modifications contained in supplements to this Service Manual.

Mechanical

- A. FILM TRANSPORT SPEEDS
 - 1. SILENT = 18 and 24 FPS
 - 2. SOUND = 18 and 24 FPS
- B. TRANSPORT MOTOR SPEEDS
 - 1. 1,080 RPM = 18 FPS
 - 2. 1,440 RPM = 24 FPS

Optical

- A. ZOOM LENS FOCAL LENGTH
 - 1. 2000 S = F/1.3, 15 to 25 MM
 - 2. 3000 S = F/1.3, 15 to 25 MM
- B. LAMP TYPE
120 VAC, 150 WATT, TYPE DNE
(TUNGSTEN-HALOGEN)

Electrical

- A. AUDIO
 - 1. Sound Film Transport Speed:
 - a. 18 FPS
 - b. 24 FPS
 - 2. Low Frequency Response: 200 Hz, ± 6 db (1000 Hz Reference)
 - 3. High Frequency Response: 4000 Hz, ± 6 db (1000 Hz Reference)
 - 4. Distortion: 6% Maximum
 - 5. Wow and Flutter: 0.6% Maximum
 - 6. Signal to Noise Ratio: -22 db
 - 7. Microphones: 600 ohm impedance
 - 8. Earphones: 400 to 600 ohm impedance
- B. GENERAL
 - 1. Supply Voltage:
120 VAC, 50/60 Hz
 - 2. Transformer Output Voltage:
 - a. Motor = 27 VAC
 - b. Sound System = 13 VAC

3.1 DISASSEMBLY PROCEDURE

Front Cover Removal

1. Place the control knob 881-826 in the OFF position.
2. While gripping the carry handle 881-504 grasp the front cover 500 at the recess around the zoom lens.
3. Pull the cover until it separates from the projector body.
3. Note the two wires leading from the speaker on the rear cover to the six-pin connector on the circuit board. Trace these wires and unplug the six-pin connector from the circuit board by pulling it straight up.
4. Lift the rear cover away.

Rear Cover Removal

1. Using a No. 2 Phillips type screwdriver, loosen the two captive rear cover screws 881-684.
2. Pull the cover 881-503 away from the projector approximately six inches and STOP.

Zoom Lens Removal

1. Remove the front cover 881-500.
2. Grasp and pull out the focus knob 881-869 as far as it will go.
3. While holding the focus knob out, pull the zoom lens out of the front of the projector.

3.2 COMPONENT LOCATION ILLUSTRATION

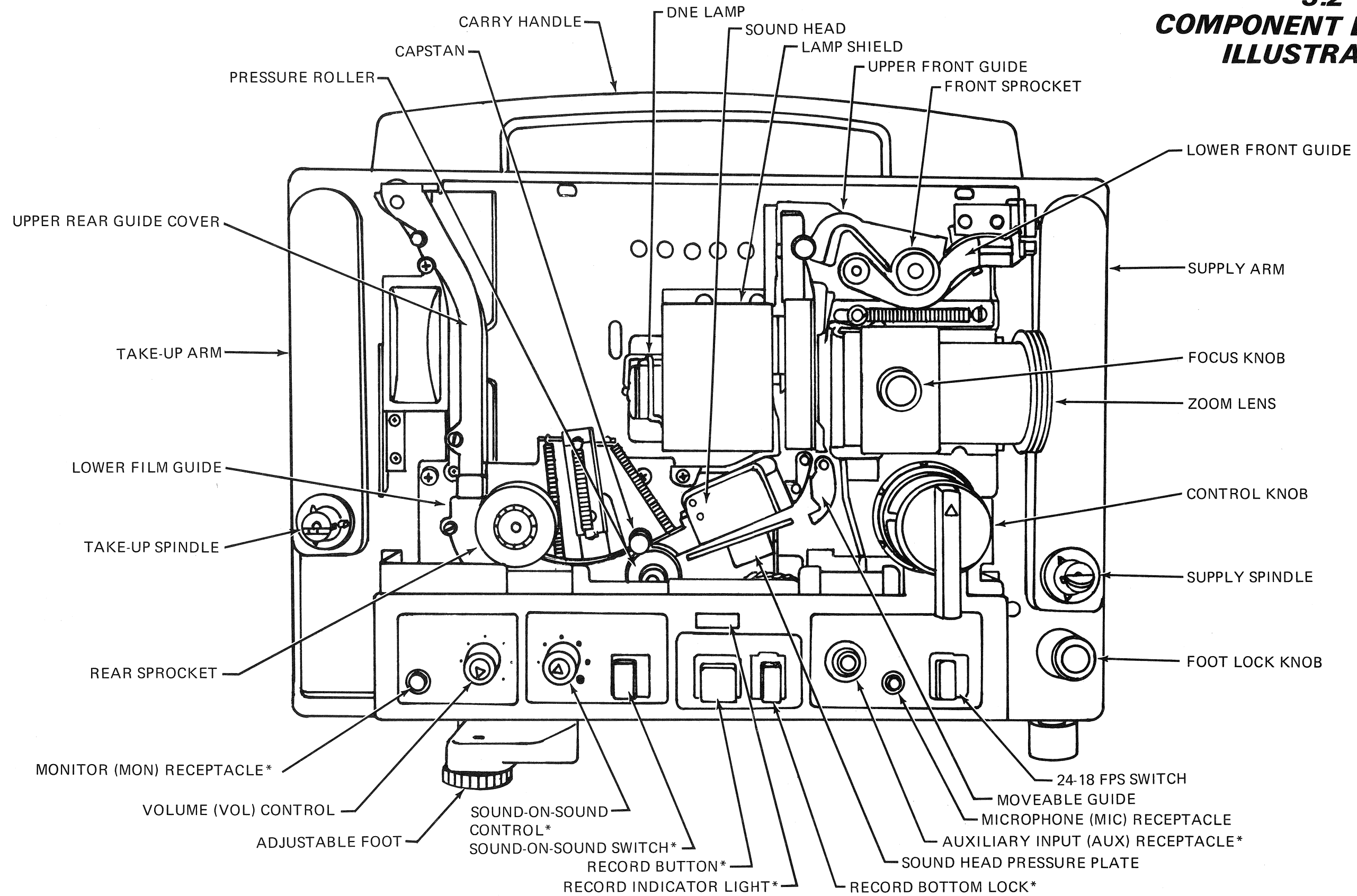

*3000 S ONLY

VIEW ONE

3.2
COMPONENT LOCATION
ILLUSTRATION

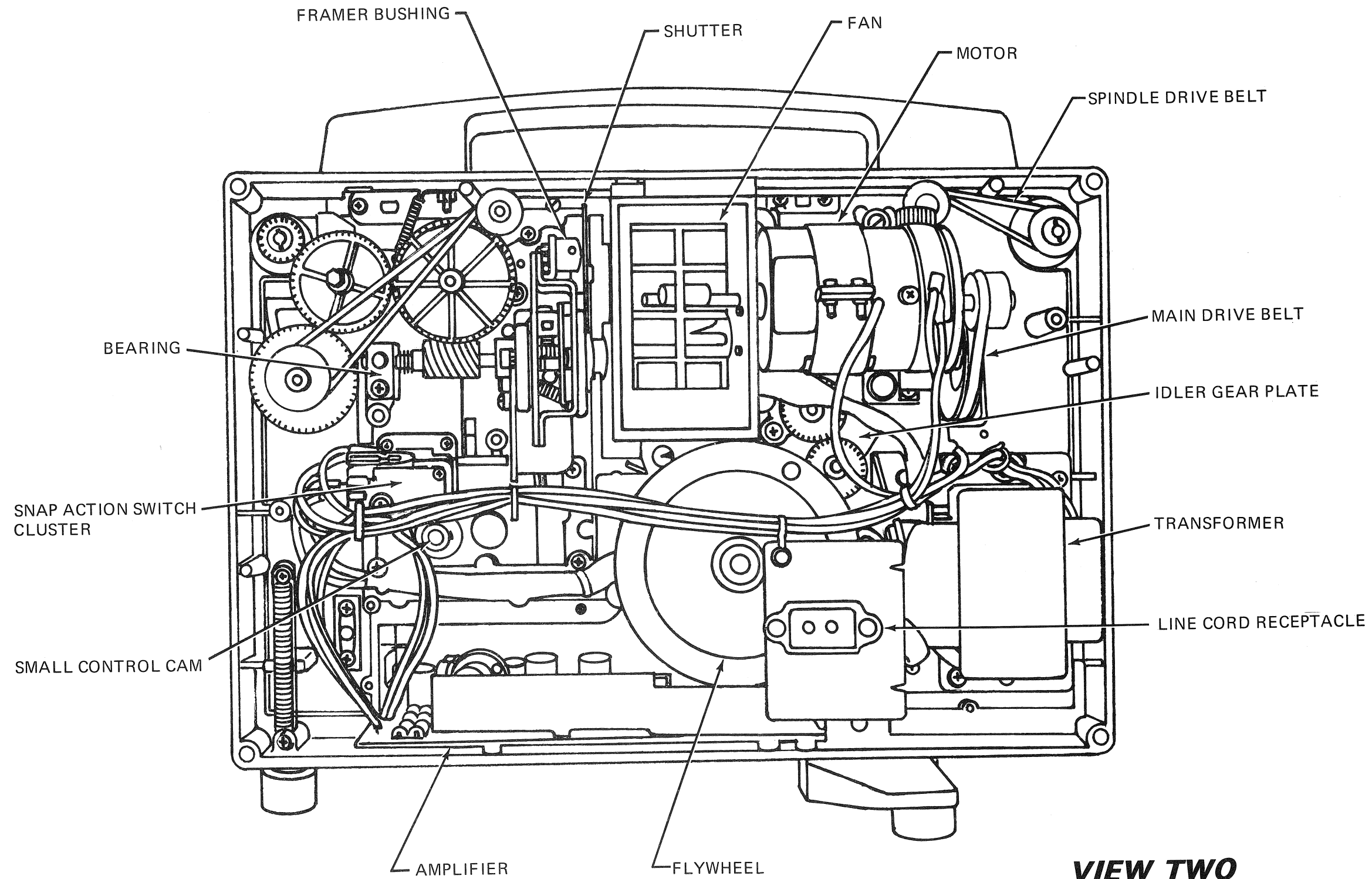

VIEW TWO

4.1 FILM TRANSPORT SYSTEM

A. Capstan/Pressure Roller

The capstan/pressure roller mechanism, identical in both models, consists of the following components:

1. *Pressure Roller Arm 881-525.*
2. *Pressure Roller 881-526.*
3. *Pressure Roller Arm Spring 881-606.*
4. *Ball Bearing 881-688.*
5. *Pressure Roller Arm Stop.*
6. *Flywheel/Capstan Bearing Assembly 881-853.*
7. *Flywheel 881-857.*
8. *Bushing 881-858.*

THEORY OF OPERATION

The function of the capstan is to move the film past the record and erase heads (3000 S only) at a steady rate of 18 or 24 frames per second $\pm 3\%$. The flywheel/capstan used in these projectors is a non-powered type which is driven by the film. When the projector is in the OFF or THREAD modes the pressure roller is held away from the capstan approximately .010 in. As the control knob is rotated to the FORWARD mode, the pressure roller comes in contact with the capstan pinching the film tightly between them. The moving film then drives the capstan and flywheel assembly which provides the stabilization effect necessary for wow and flutter-free sound reproduction.

ADJUSTMENT

Proper clearance between the capstan and the pressure roller is adjusted as follows:

1. Place the control knob in the OFF position.
2. Remove the front cover.
3. Pull off the Volume Control Knob (2000 and 3000) and the Sound-On-Sound Control Knob (3000 only).
4. Remove the two screws 505-020 from the control panel nameplate 881-814 or 881-818 and lift the nameplate off.
5. Locate the large recessed portion in the center of the control panel 881-830 and note the square hole in the upper left corner of the recess. This is the access hole for the pressure roller arm stop lock screw 505-055. (See figure 4-1.)
6. Loosen the lock screw and adjust the pressure roller arm stop until there is .010 in. (0.25 MM) clearance between the outer edge of the pressure roller and the capstan.
7. Tighten the lock screw and move the control knob through its full range of travel several times, and stop at the OFF position.
8. Recheck the clearance and readjust if necessary.

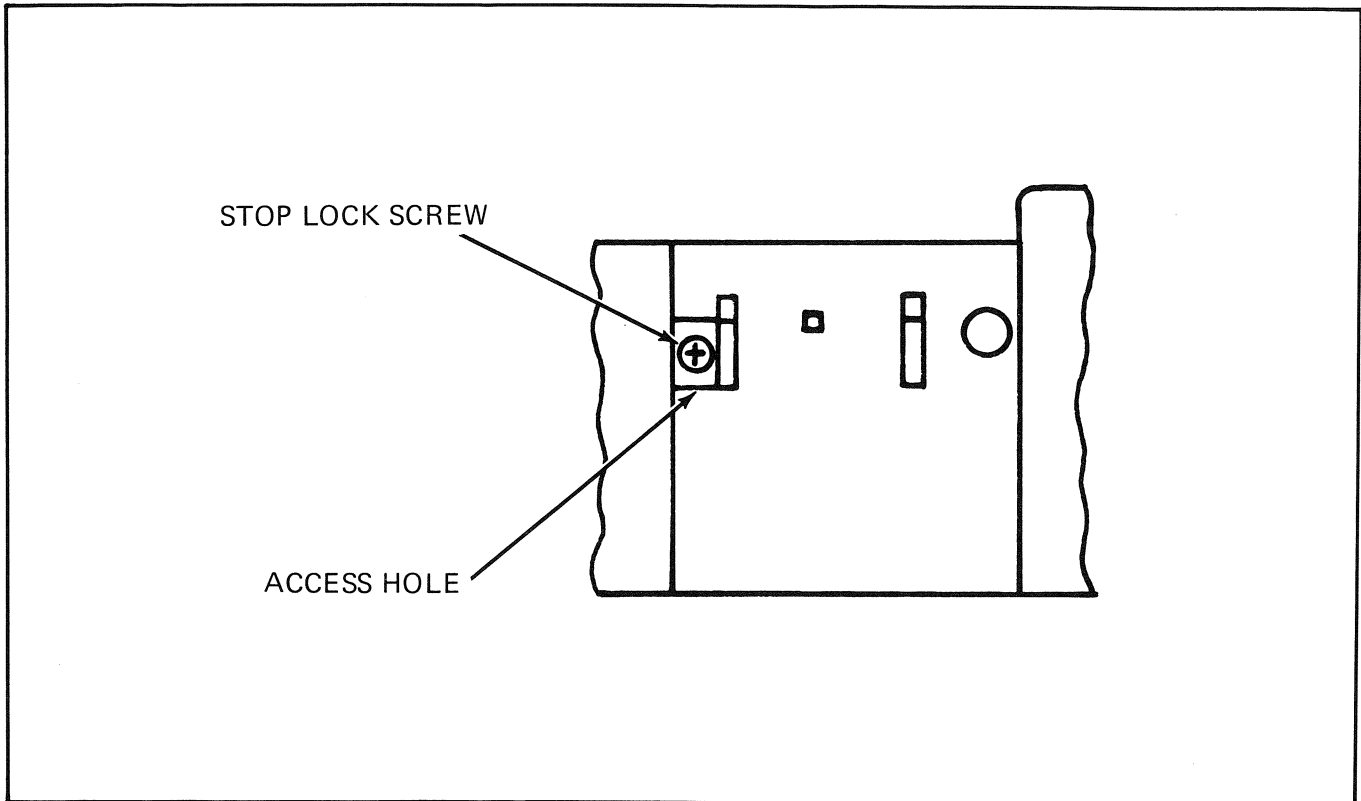

Fig. 4-1

REPAIR

Repairs to this mechanism are limited to replacement of defective or reattachment of loose components.

4. Slide the shutter back and forth on its shaft until the claw extends 0.5 MM (0.020 in.) above the outside rail of the aperture plate 881-843.
5. Tighten the set screw in the shutter hub.

B. Claw/Framer

The claw/framer mechanism consists of the following major components:

1. *Shutter 881-532.*
2. *Framer Shaft Assembly 881-535.*
3. *Claw Arm 881-689.*

CLAW ADJUSTMENT

Claw depth into the aperture plate is adjusted as follows:

1. Remove the front and rear housing.
2. Using a 5/64 Allen wrench, loosen the set screw on the shutter hub until the shutter slides easily on the shaft.
3. Manually rotate the shutter until the claw reaches its maximum depth.

FRAMER ADJUSTMENT

The claw moves in a non-adjustable, rectangular path in relationship to the fixed aperture. (See figure 4-2.) Adjustment changes the relationship between the claw and the aperture. Proceed as follows:

1. Remove the front and rear housings.
2. Loosen the hex nut 881-626 one full turn. (See figure 4-3.)
3. Manually rotate the shutter 881-532 until the tip of the claw on the claw arm 881-689 is centered vertically in the slot on the plate 881-844. (See figure 4-4.)
4. Rotate the framer shaft 881-535 until the framer bushing 881-862 is centered

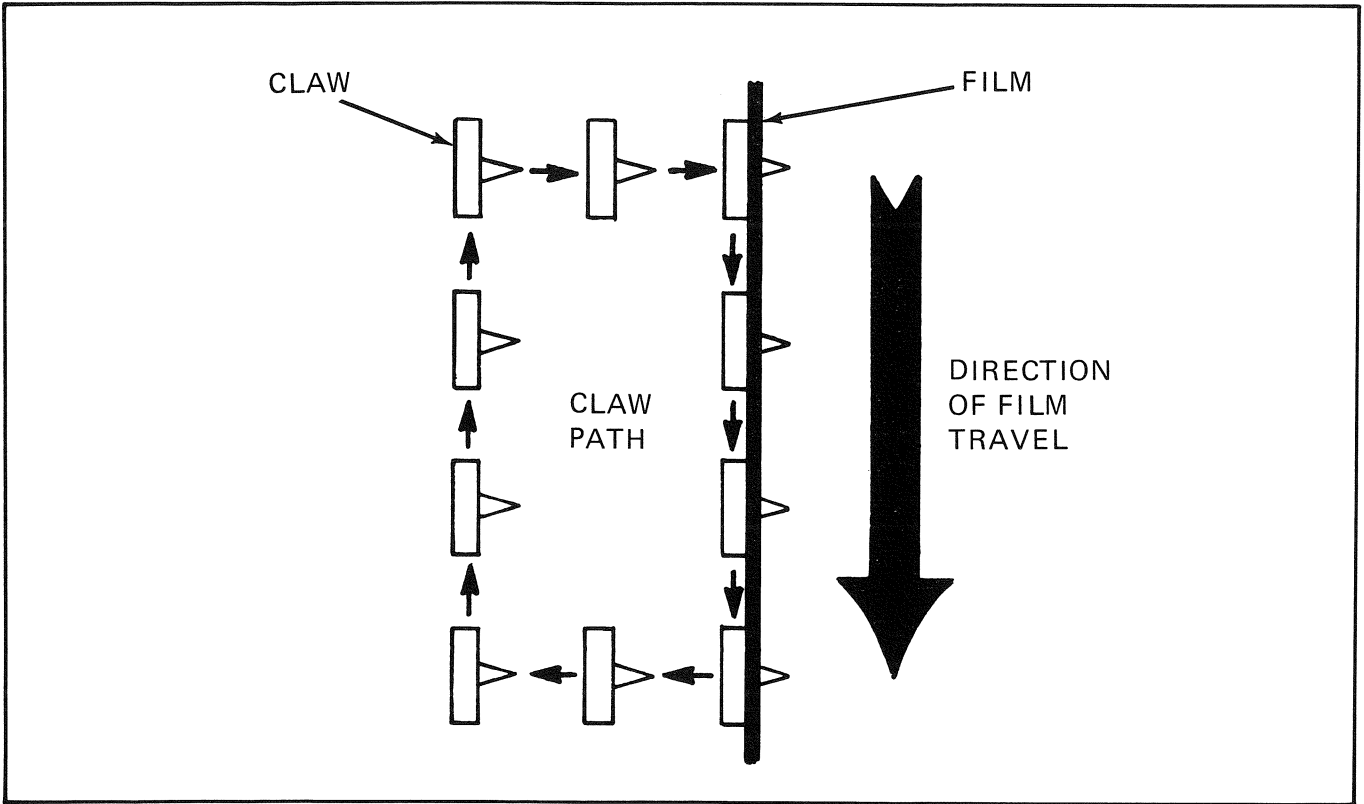

Fig. 4-2

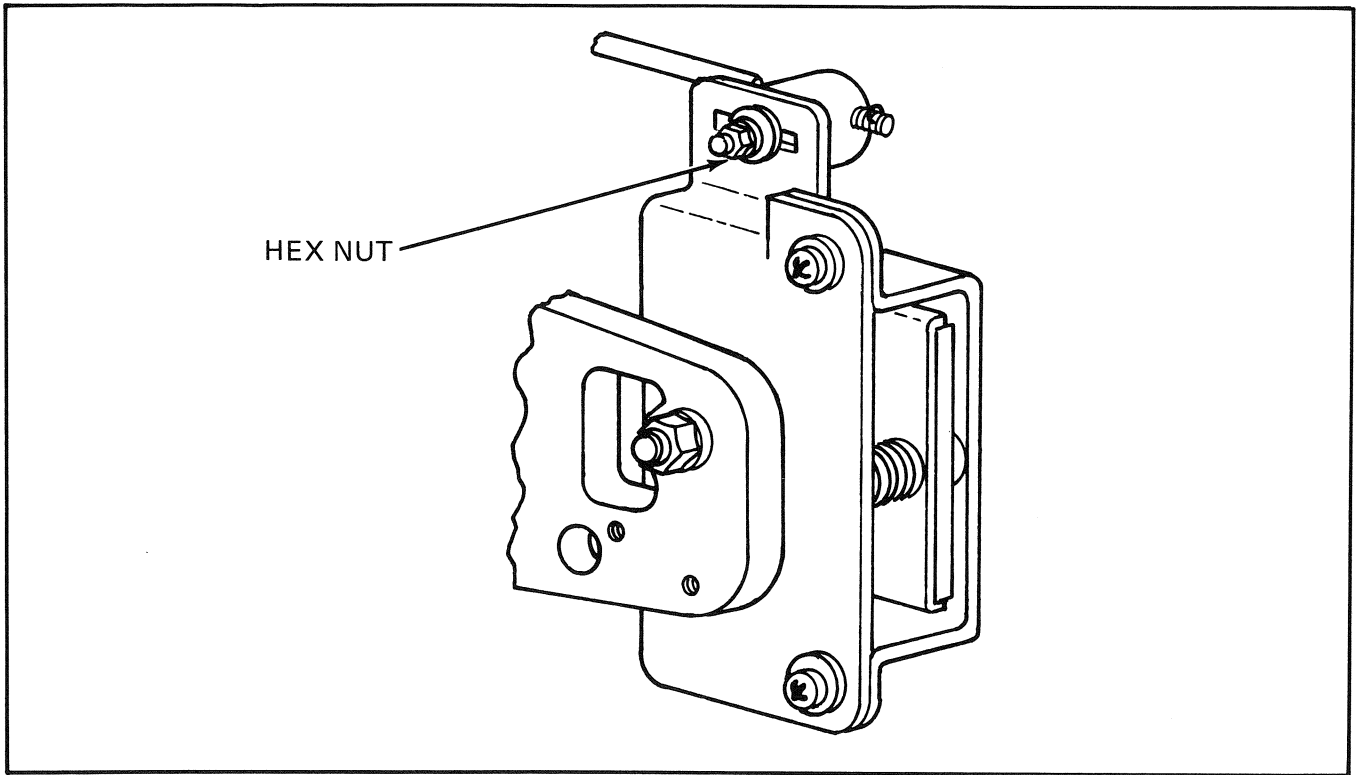

Fig. 4-3

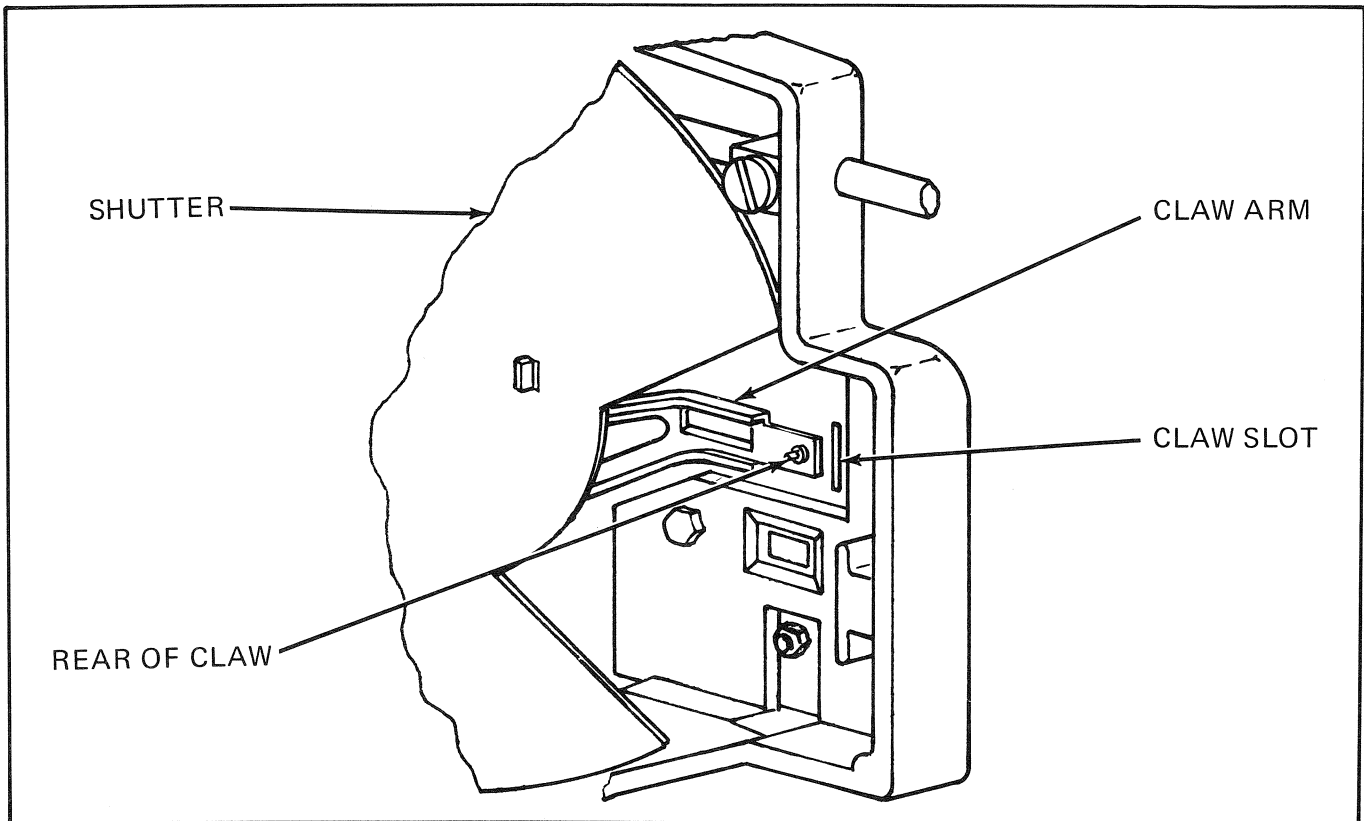

Fig. 4-4

between the shoulder and the wire clip on the threads of the framer shaft. (See figure 4-3.)

5. Tighten the hex nut 881-626.

REPAIR

Defective components are replaced.

C. Film Path

The film path for both models is illustrated in the following diagram, figure 4-5, page 4-5.

ADJUSTMENT

There are ten possible adjustment areas in the film path. See the foldout figure 4-6 on page 4-7.

Adjustments A, B, E, F, G, H, and J will be covered here. Adjustments C and D will be found under the Optical System, page 4-11. Adjustment I will be found under Capstan/Pressure Roller, page 4-1.

The area of adjustment can be determined by noting where in the film path the trouble occurs

and cross-referencing the area to illustration 4-6. The adjustment immediately ahead of the film would be the most likely place to begin.

FRONT SPROCKET ADJUSTMENT (See A, figure 4-6)

This fourteen tooth sprocket is gear-driven at a constant speed of 78 RPM. When properly mounted, there should be no perceptible end play on the sprocket shaft. If end play is apparent, proceed as follows:

1. Remove the rear housing.
2. Apply force to the pushnut 881-630 until all end play is removed.

NOTE

Too much force applied to the pushnut will cause excessive friction. Tighten only enough to remove any end play.

LOWER FRONT GUIDE ADJUSTMENT (See B, figure 4-6)

This guide pivots against a spring and is retained by a pushnut on its shaft. There should

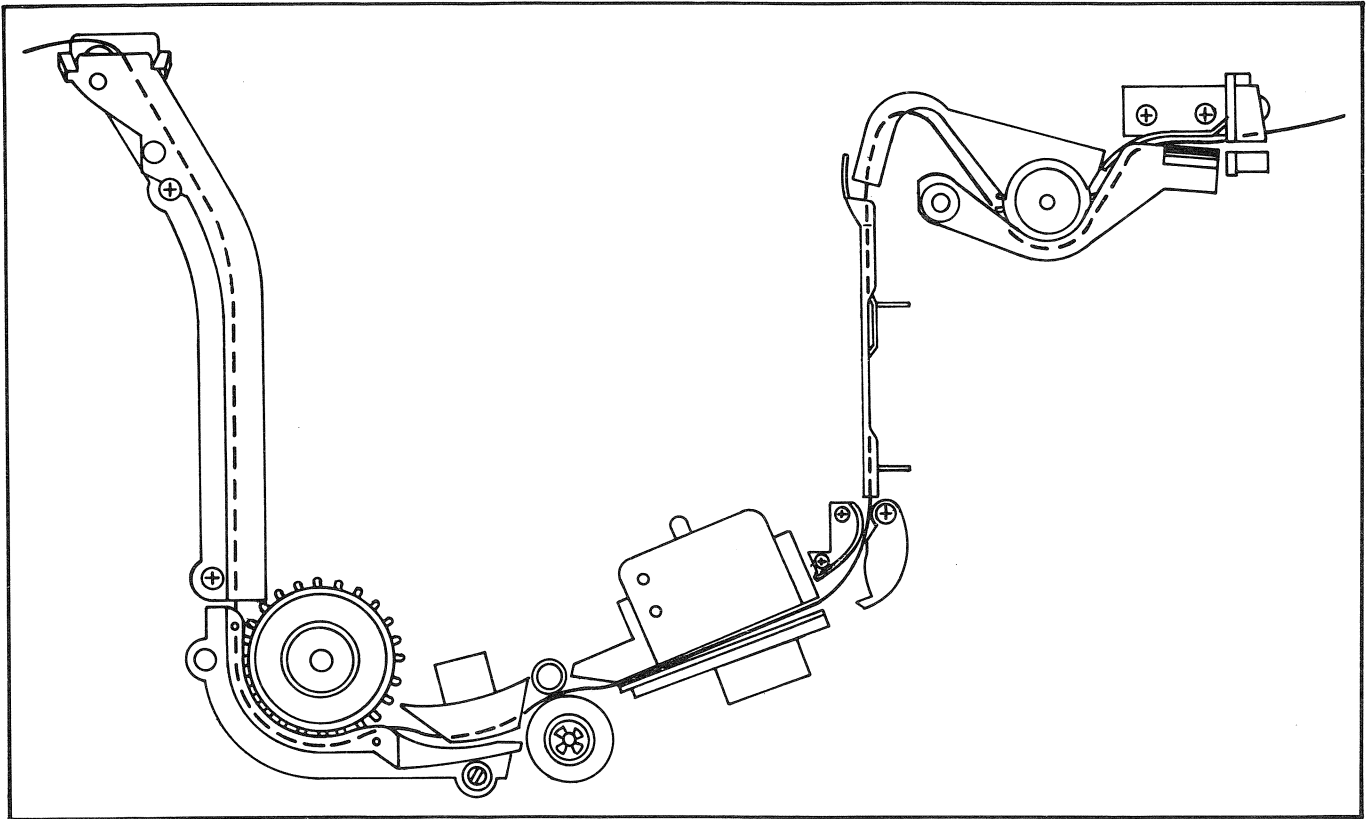

Fig. 4-5

be no end play between the pushnut and the guide. Proceed as follows:

1. Remove the front housing.
2. Apply force to the pushnut 881-630 until all end play is removed.

FIXED GUIDE ADJUSTMENT (See E, figure 4-6)

1. Remove the front housing.
2. Without loosening the two screws 505-010, move the guide as necessary to insure proper film transport.

MOVEABLE GUIDE ADJUSTMENT (See F, figure 4-6)

The moveable guide directs the film into the sound head when the projector is in the THREAD mode and retracts allowing the loop to form when the projector is in the FORWARD mode. The guide should pivot freely on its shaft and should be held firmly against the fixed guide when the

machine is in the THREAD mode. Movement of the guide is controlled by the loop guide tension spring 881-691 which should be adjusted to insure proper guide positioning in both modes.

SOUND HEAD ADJUSTMENT (See G, figure 4-6)

An improperly adjusted sound head may cause a film jam at the front of the head or at the capstan/pressure roller. Adjust as follows:

1. Remove the front and rear housings.
2. Set projector to the OFF mode.
3. Loosen the three screws 505-013 at the rear of the sound head.
4. Adjust the sound head until the top of the head mask 881-016 is aligned with the center of the capstan shaft 881-012. (See figure 4-7.)
5. Tighten the three screws 505-013 and recheck the adjustment.

SOUND HEAD PRESSURE PLATE ADJUSTMENT (See H, figure 4-6)

Insufficient or excessive clearance between the sound head 881-502 or 881-543 and the pressure plate 881-524 may cause the film to jam. Clearance is checked between the rear of the sound head and the pad on the pressure plate arm 881-523. (See figure 4-7.)

Proceed as follows:

1. Remove the front housing.
2. Place projector in the THREAD mode.
3. Measure the clearance as shown in figure 4-7.
4. If clearance is not .125 in., bend the pressure plate arm at the spring clearance notch immediately behind the control cam 881-828 until clearance is correct.

NOTE

This adjustment also affects the capstan/pressure roller clearance. Check and adjust the pressure roller whenever this adjustment is made.

LOWER FILM GUIDE/REAR SPROCKET ADJUSTMENT (See J, figure 4-6)

Improper clearance between the lower film guide and the rear sprocket can cause film jamming. Proper clearance is obtained when one-half of the sprocket teeth are covered by the film guide. (See figure 4-8.)

A limited amount of adjustment is possible by moving the lower guide after loosening the lower guide screw 881-531. (See figure 4-8.)

If further adjustment is required, proceed as follows:

1. Remove the front and rear housing.
2. Make the best possible alignment of the lower film guide 881-531 and tighten the screw 881-707.
3. Remove the flywheel 881-857.
4. Remove the screws 505-040 and lift off the pivot plate 881-522.
5. Remove the rear sprocket gear 881-879.
6. Loosen the three screws 505-026.

7. Move the rear sprocket bearing 881-538 until the proper clearance between the sprocket and film guide is obtained.
8. Tighten the three screws 505-026.
9. Replace the sprocket gear, pivot plate, and flywheel.

REPAIR

Repair to film path components is limited to tightening of loose and replacement of defective components.

D. Drive Train

Power flow from the motor through the drive train is illustrated by figure 4-9, page 4–10.

ADJUSTMENTS

Since most drive train components are mounted on fixed shafts, they are not adjustable. Only two adjustments are possible, the shutter shaft and drive shaft bearings and the idler gear plate assembly. (See figure 4-10.)

BEARING ADJUSTMENT

Improperly adjusted bearings cause excessive friction and increased current draw at the drive motor. Adjust as follows:

1. Connect an ammeter in series with the drive motor.
2. Loosen the screws holding the bearing retainers 881-897.
3. Place the projector in FORWARD mode.
4. While the machine is running, tap the bearings lightly until the lowest current draw reading is obtained.
5. Tighten the bearing retainer screws and recheck current draw.

IDLER GEAR PLATE ADJUSTMENT

Improper gear mesh can cause binding and excessive wear. Adjust as follows: (See figure 4-10.)

1. Remove the rear housing.

FIGURE 4-6

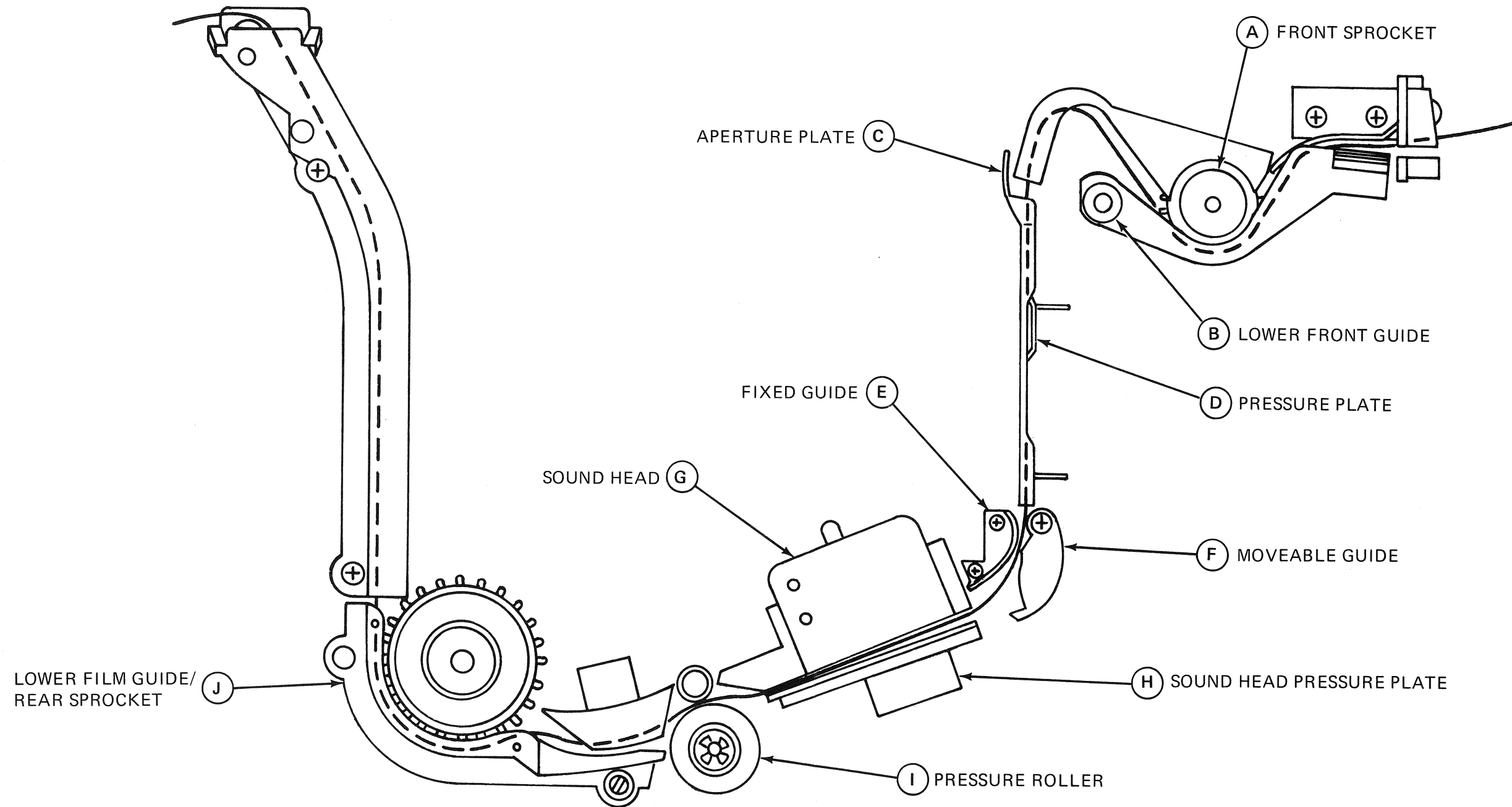

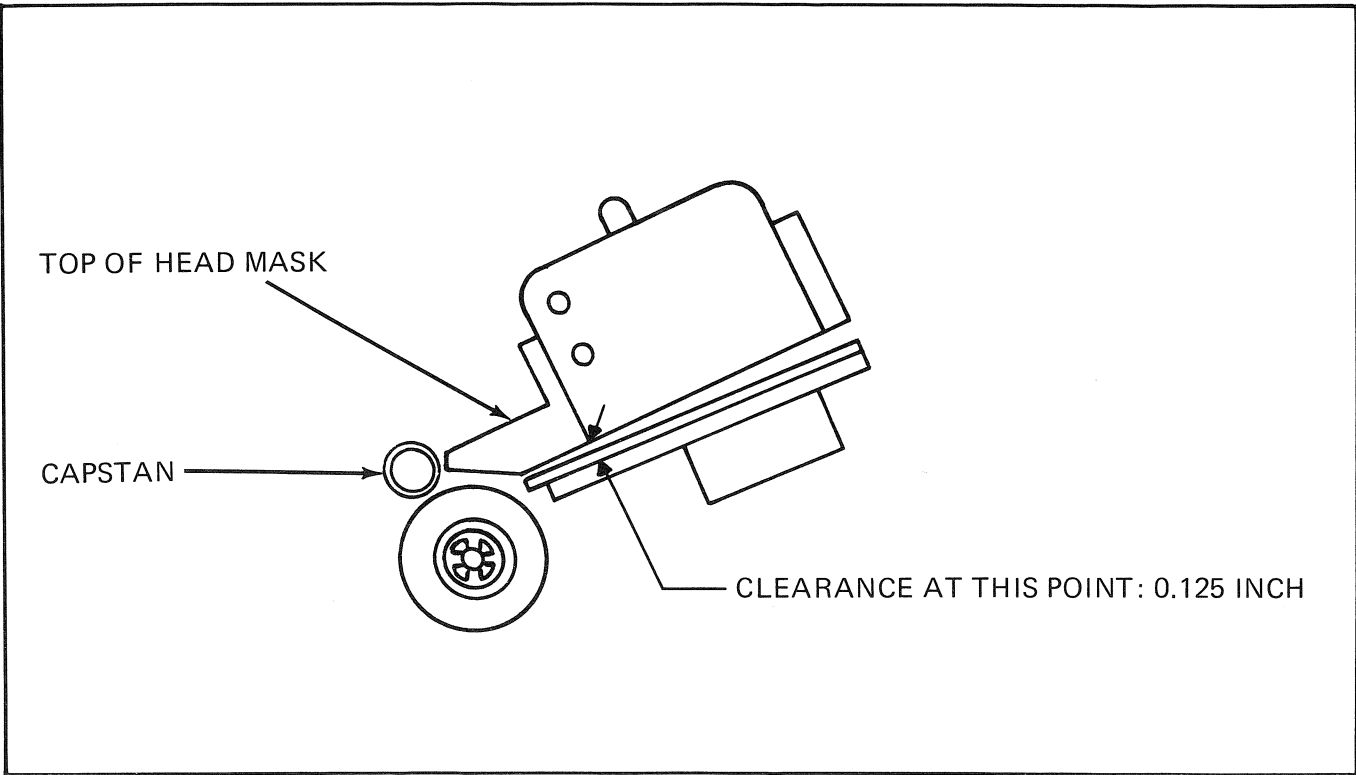

Fig. 4-7

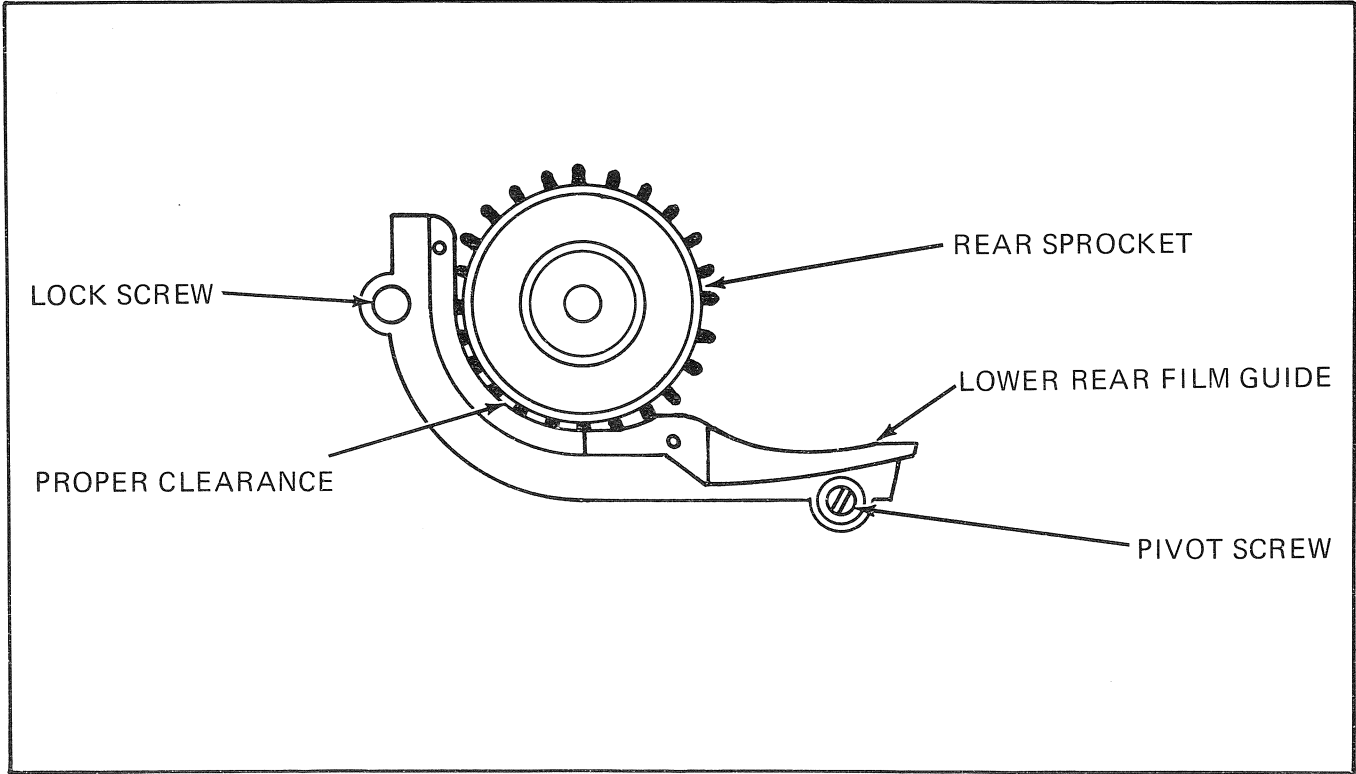

Fig. 4-8

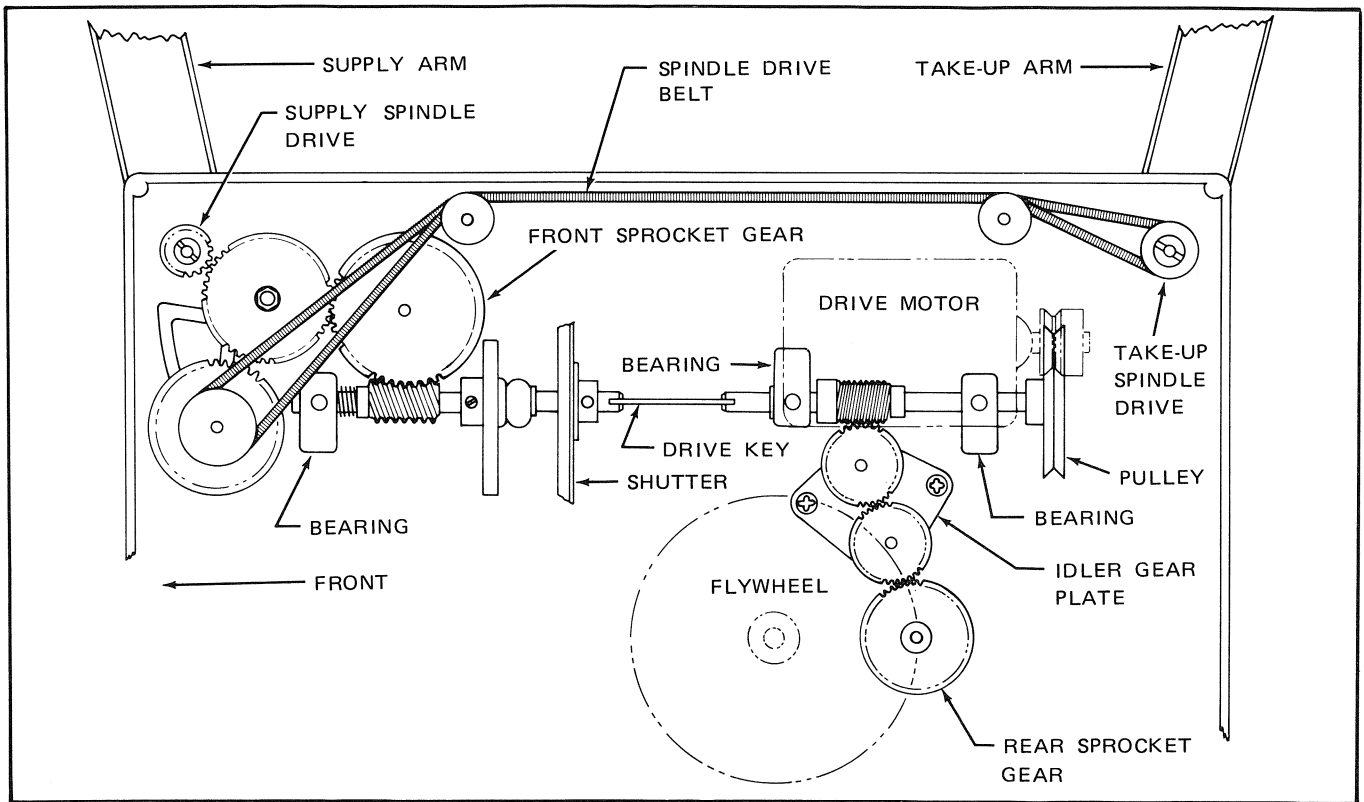

Fig. 4-9

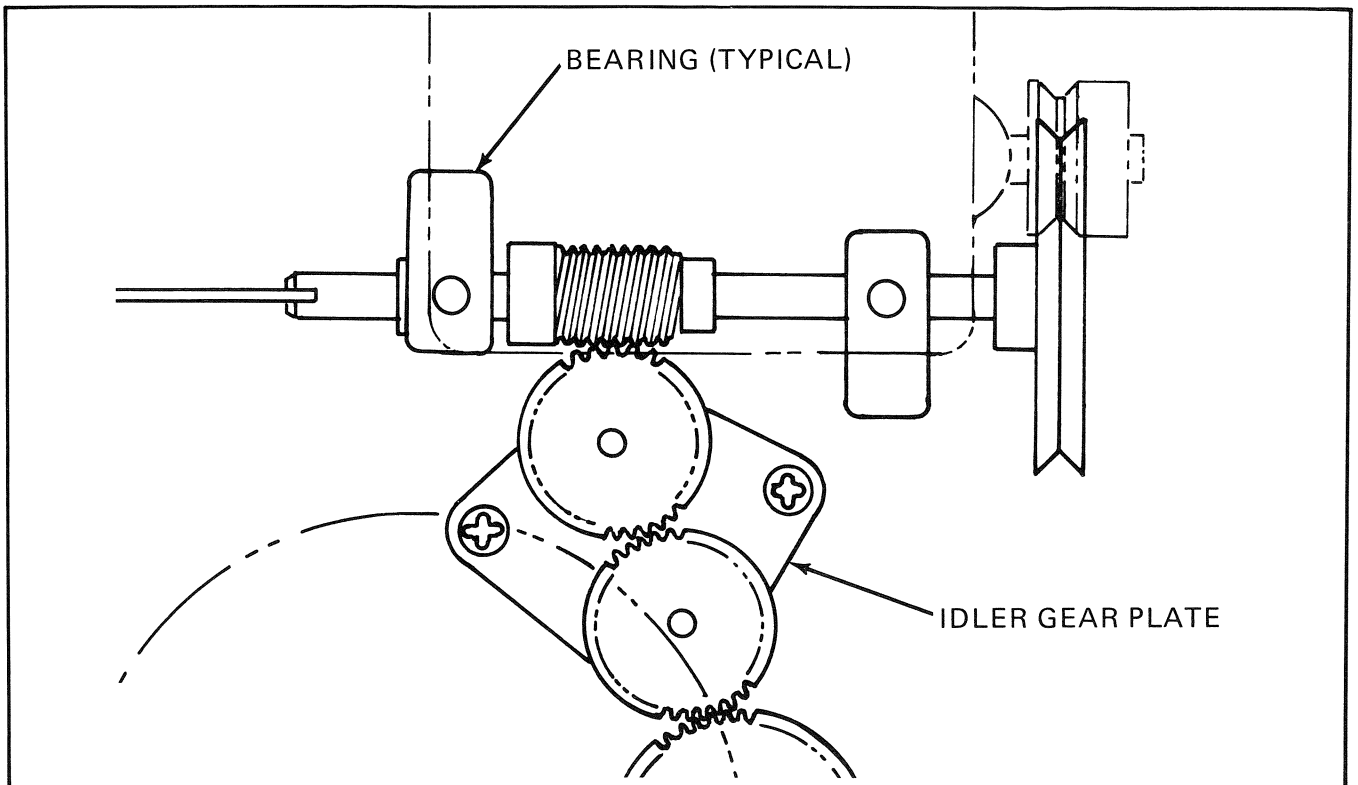

Fig. 4-10

2. Loosen the two screws 505-040.
3. Move the plate until proper one-half tooth engagement is obtained at the worm gear and the rear sprocket drive gear. (See figure 4-11.)
4. Tighten the two screws.

REPAIR

Defective components are replaced.

LUBRICATION

1. All bearings should be lubricated with a small amount of NYE Delicate Instrument Oil No. 145.
2. All gears and cams should be lubricated with a small amount of NYE Rheolube No. 734A.

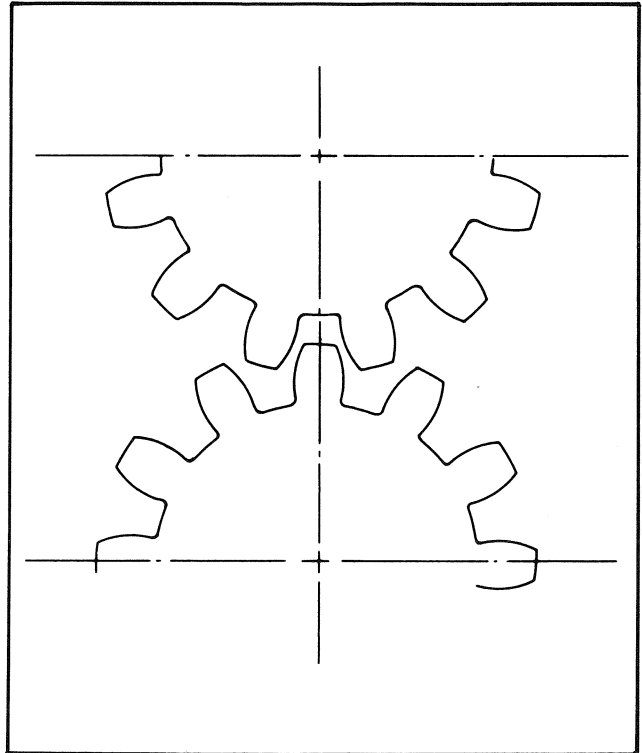

Fig. 4-11

4.2 OPTICAL SYSTEM

A. Lamp

Both models use a type DNE, Tungsten-Halogen projection lamp.

ADJUSTMENT

Uneven illumination of the aperture may be caused by a misadjusted lamp socket or a defective lamp. Proceed as follows:

1. Remove the front housing.
2. Remove the lamp heat shield 881-831.
3. Loosen the two screws 505-031 attaching the lamp socket 881-000.
4. Place the projector in the FORWARD mode.

WARNING

The unshielded projection lamp is an intense heat and light source. Wear eye protection. The projection lamp operates on 120 VAC. Observe safety rules for repair of energized electrical circuits.

5. Move the lamp socket until the aperture is evenly illuminated.
6. Tighten the two screws 505-031.

NOTE

If the adjustment procedure does not work, the lamp may be defective. Install a new lamp and check for even illumination.

REPAIR

Defective lamps are replaced. Defective lamp sockets are usually replaced unless the problem is a disconnected wire to the socket.

B. Aperture/Pressure Plate

The aperture/pressure plate mechanism consists of the following major components:

1. *Pressure Plate Bracket 881-841.*
2. *Pressure Plate 881-842.*
3. *Aperture Plate 881-843.*
4. *Mounting Plate 881-844.*
5. *Spacer 881-845.*

APERTURE ADJUSTMENT

The aperture is adjusted to correct keystoneing, a condition caused when the aperture is not square to the lamp, pressure plate and lens axis. Proceed as follows:

1. Adjust the projector feet until the unit sits flatly and squarely.

2. Remove the front housing.
3. Remove the lamp heat shield 881-831.
4. Locate the aperture adjusting screw 505-008. (See figure 4-12.)
5. Turn the screw as necessary until the aperture is square.

NOTE

The adjusting screw will break if tightened excessively.

6. Glue the head of the adjusting screw.

NOTE

Whenever the aperture is adjusted, the claw depth must be checked and adjusted, if necessary.

PRESSURE PLATE ADJUSTMENT

The pressure plate profile must be correct to insure that the film is held flatly as it passes the aperture. Adjust as follows:

1. Remove the front housing.
2. Remove the pressure plate.

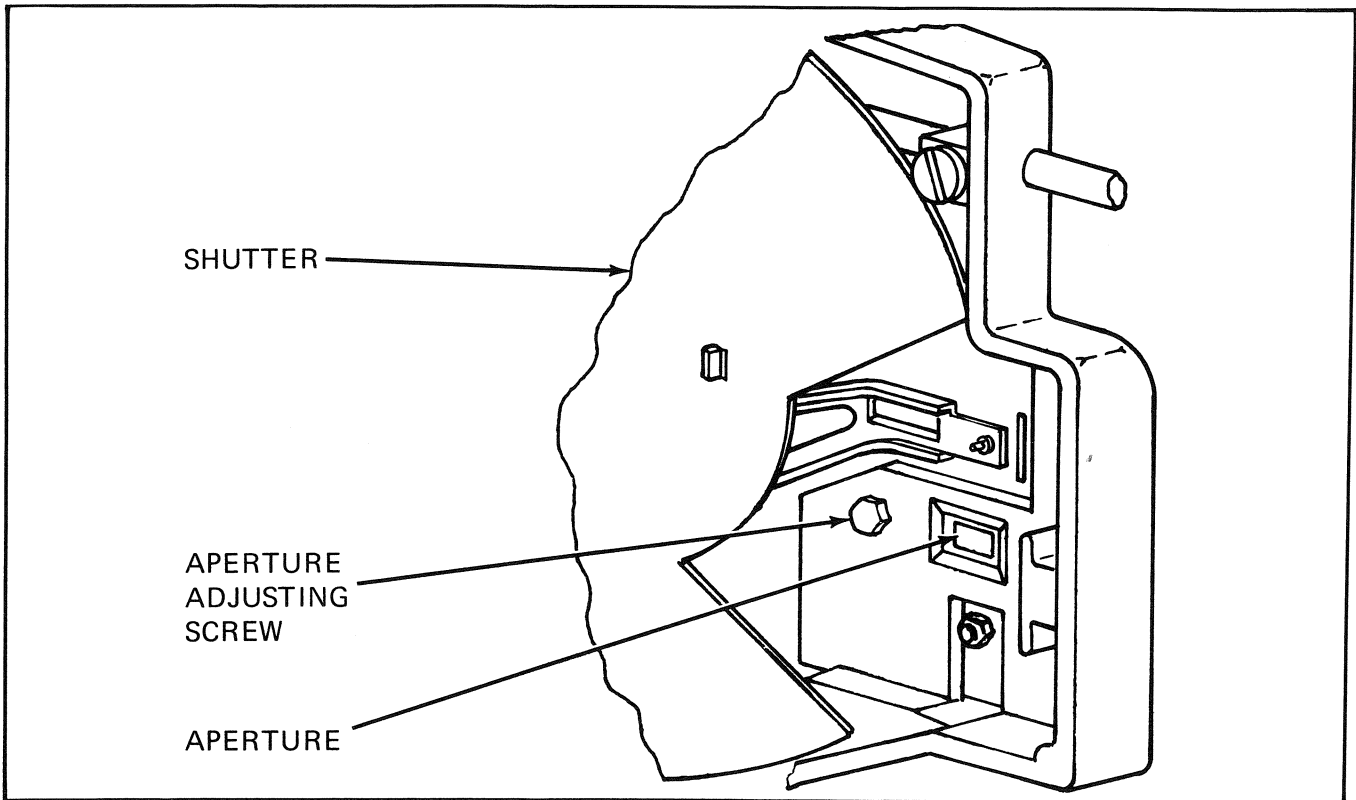

Fig. 4-12

3. Form the pressure plate until it conforms to the profile illustrated in figure 4-13.
4. Install the pressure plate and test for proper function.

NOTE

Marred or scratched pressure plates should always be replaced.

REPAIR

It is important that neither the aperture plate nor the pressure plate have any imperfections that could cause film scratches. When in doubt, replace components as necessary.

C. Shutter

The 2000 S, 3000 S and SEARS 9258 Sound Projectors are equipped with a three-bladed shutter.

ADJUSTMENT AND REPAIR

The shutter consists of the hub, the shutter blade, and the claw control cam. These three components are joined as an assembly and there must be no movement between them. If one or more of the shutter components is loose, tighten the three screws 505-009. If tightening the screws does not eliminate the looseness, the shutter must be replaced.

The shutter is not adjustable. However, the position of the shutter is used to adjust claw depth. Whenever the shutter is replaced the claw depth must be checked and adjusted according to the procedure on page 4-2.

D. Zoom Lens

The zoom lens assembly is not repairable. Defective lens units should be replaced. However, the zoom lens bracket 881-868 or the cam on the focus knob shaft 881-670 can be adjusted as a remedy for the following troubles:

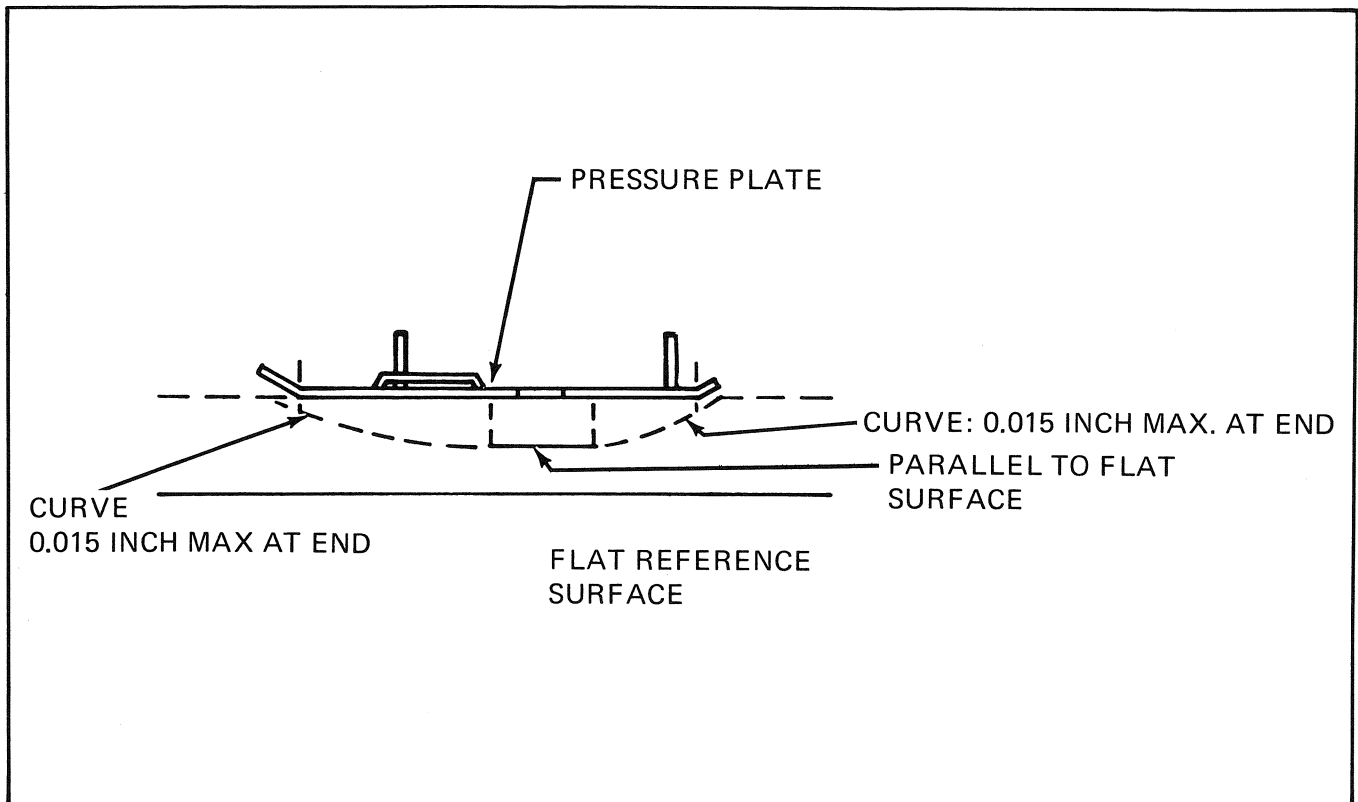

Fig. 4-13

1. Lens will not stay in focus.
2. Lens difficult to focus.
3. Lens jump when focused.

FOCUSING CAM ADJUSTMENT

1. Remove the zoom lens.
2. Remove the zoom lens bracket.
3. Check the fit of the cam into the slot in the lens. The fit should be snug but not tight.
4. File the cam until proper fit is obtained.

5. Replace zoom lens bracket.

ZOOM LENS BRACKET ADJUSTMENT

1. Install the zoom lens.
2. Loosen the four screws 550-018.
3. Move the bracket until the smoothest possible lens movement is obtained.
4. Tighten the four screws.

REPAIR

If adjustment does not remedy the focus problem, replace defective components as necessary.

4.3 ELECTRICAL SYSTEM

A. Motor

The relationship of the motor and its control circuits to the other elements of the electrical system is illustrated in the block diagrams on pages 5-5 and 5-7.

FUNCTION TESTS

1. Motor Current Draw
 - a. Connect a DC ammeter in series with the motor.
 - b. Turn the projector to the FORWARD mode and note the ammeter reading. It should be between 550 and 700 milliamperes.
2. Motor Voltage Regulator Power Supply
 - a. Connect a DC voltmeter across the 1000 uf, 50 VDC electrolytic capacitor on the amplifier circuit board.
 - b. Turn the projector to the FORWARD mode and note the voltmeter reading. It should be 32.0 VDC \pm 20% with the motor running.
3. Motor Voltage Regulator
 - a. Connect a DC voltmeter across the blue and white wires on the snap-action switches S1 and S2.
 - b. Set the frames-per-second selector switch to 18.

- c. Turn the projector to the FORWARD mode and note the voltmeter reading. It should be 20.0 VDC \pm 20%.
- d. Set the 24-18 selector switch to 24.
- e. Note the voltmeter reading. It should be 25 VDC \pm 20%.

ADJUSTMENT

Excessive current draw can be caused by high friction in the drive train or poor motor brush contact. Drive train adjustment is outlined on page 4-6. Brush contact is adjusted by removing the brush and filing the end to the proper contour with a round file.

MOTOR (18 and 24 FPS) SPEED ADJUSTMENT

1. Remove the front housing.
2. Locate the access slot for the speed adjustment variable resistors. (See figure 4-14.)
3. Set the 24-18 selector switch to 18 and turn the projector to the FORWARD mode.
4. Aim a properly calibrated strobe, set to 1,080 RPM, at the shutter.
5. Adjust the 18 FPS variable resistor until the shutter is frozen.
6. Set the 24-18 selector switch to 24.

7. Aim a properly calibrated strobe, set to 1,440 RPM, at the shutter.
8. Adjust the 24 FPS variable resistor until the shutter is frozen.

REPAIR

Defective components are replaced.

B. Snap-Action Switch Cluster

The relationship and function of the snap-action switches to the other elements of the electrical system are illustrated by the block diagrams on pages 5-5 and 5-7.

FUNCTION TEST

The three identical snap-action switches 881-808 are identified as follows:

DESIGNATION	POSITION	CONTROLS	VOLTAGE CARRIED
SW1	Outer	Motor (Rev.)	20 to 30 VDC
SW2	Middle	Motor (Fwd.)	20 to 30 VDC
SW4	Inner	Lamp	120 VAC

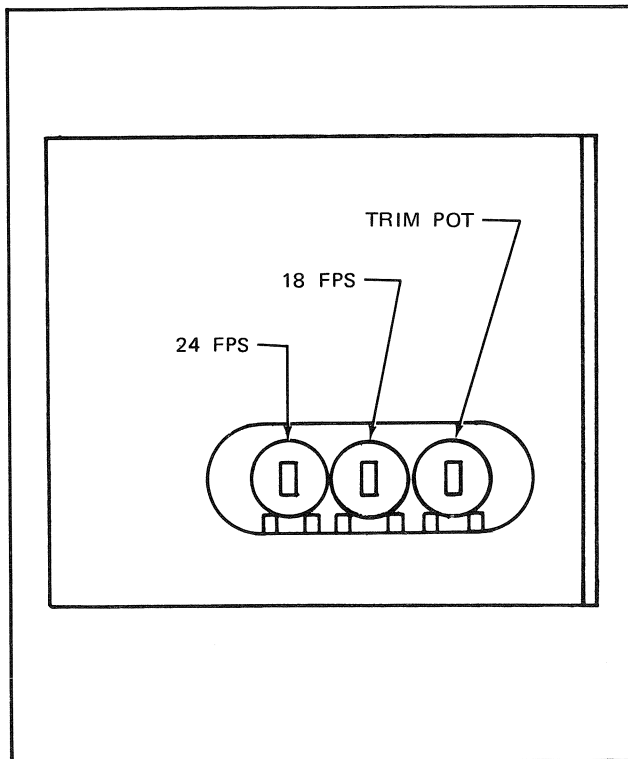

Fig. 4-14

Switch operation is controlled by the small control cam 881-529 which moves as the control knob 881-826 is turned.

ADJUSTMENT

Proper control cam to switch actuator relationship is adjusted as follows:

1. Remove the rear housing.
2. Place the projector in the OFF mode.
3. Loosen the setscrew in the small control cam 881-529.
4. Rotate the cam until the center switch actuator is fully depressed and positioned on the highest part of the center cam. The inner and outer switch actuators should be fully extended.
5. Tighten the setscrew.

6. Operate the machine in its various modes as a switch test. See Mode Chart on page 6-1.

REPAIR

Defective switches are replaced.

C. Transformer

The relationship of the transformer to the other elements of the electrical system is illustrated in the block diagrams on pages 5-5 and 5-7.

WARNING

The AC line voltage to the projection lamp is taken from the primary side of the transformer. No isolation protection is present.

REPAIR

Defective transformers are replaced.

D. Sound Record/Reproduce System

The relationship of the record/reproduce system to the other elements of the electrical system is illustrated in the block diagrams on pages 5—5 and 5—7.

The record/reproduce system consists of the following major components:

1. *Record Head (2000 S) 881-502.*
2. *Record/Reproduce Head (3000 S) 881-543.*
3. *Amplifier Circuit Board (2000 S) 881-579.*
4. *Amplifier Circuit Board (3000 S) 881-542.*
5. *Speaker 881-804.*

FUNCTION TESTS

1. Amplifier and Bias Oscillator Power Supply
 - a. Connect a DC voltmeter across the 1000 uf, 25V electrolytic capacitor on the amplifier circuit board.
 - b. The meter should read 15.0 VDC \pm 20%.
2. Integrated Circuit No. 1 (IC-1)
 - a. Place projector in the FORWARD mode.
 - b. Touch a screwdriver blade to pin 4 of connector P2.
 - c. A click heard in the speaker indicates a good IC1.
3. Integrated Circuit No. 2 (IC-2)
 - a. Tap the center terminal of the volume control potentiometer with a screwdriver.
 - b. If a click is heard in the speaker, IC2 is good.
4. Speaker Windings
 - a. Using a VOM set to X1, place the meter leads to the speaker terminals.
 - b. The resistance reading should be 8 ohms \pm 10%.
5. Record/Reproduce Head

- a. Using a VOM set to X10, place the meter leads to pins 3 and 4 of connector P2.
 - b. Resistance reading should be 260 ohm \pm 10%.
6. Erase Head (3000 S ONLY)
 - a. Using a VOM set to X1, place the meter leads to pins 1 and 2 of connector P2.
 - b. Resistance reading should be 3 to 4 ohms.
 7. Bias Oscillator (3000 S ONLY)
 - a. Connect an AC voltmeter between pins 1 and 2 of connector P2.
 - b. With the projector in the RECORD mode and the SOUND-ON-SOUND ON-OFF SWITCH in the OFF position, the meter reading should be 20 VAC \pm 20%.
 8. Bias Voltage at Record/Reproduce Head (3000 S ONLY)
 - a. Connect an AC voltmeter between pins 3 and 4 of connector P2.
 - b. With the projector in the RECORD mode and no audio input, the meter reading should be 7.5 VAC \pm 10%.

ADJUSTMENTS

Bias Voltage at Sound Head Adjustment (3000 S ONLY)

1. Connect an AC voltmeter to pins 3 and 4 of connector P2.
2. Place the projector in the RECORD mode with no audio input.
3. The meter should read 7.5 VAC \pm 10%.
4. If the voltage reading is not 7.5 VAC, adjust the potentiometer R37 until the correct reading is obtained.

SOUND HEAD ALIGNMENT

1. Thread a roll of prerecorded film containing a 1000 Hz signal through the projector.
2. Connect an audio voltmeter to the EXTERNAL SPEAKER receptacle on the projector.

3. Place the projector in the FORWARD mode and note the meter reading.
4. Using the projector VOL control, adjust the audio output until the meter reads approximately center scale.
5. Turn the adjusting screws on the sound head, alternately, until the highest possible meter reading is obtained. (See figure 4-15.)

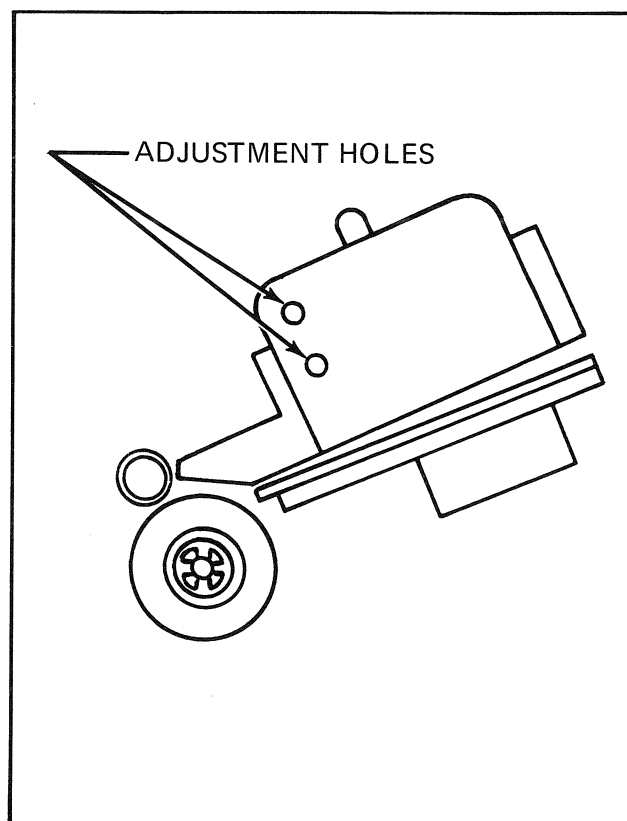

Fig. 4-15

The block diagrams, wiring diagrams, and schematics in this manual display the following information:

- A. Component callouts
- B. Component values
- C. Test points
- D. Proper voltage readings at the test point.

Component callouts, usually a combination of a letter and a number such as D5, R8, or Q12, are located at the component symbol or pictorial representation.

Component values are located adjacent to the component callout.

Test points, indicated by a letter enclosed in a triangle, denote the exact point at which a test meter probe should be placed in the circuit to obtain a reading. The test points are uniform throughout the manual. Test point A on the schematic is the same as test point A on the block diagram and the wiring diagram.

Immediately adjacent to the test point triangle is a numerical value which represents the proper voltage reading which should be present at that test point.

5.1 2000 S and 3000 S Wiring Diagram

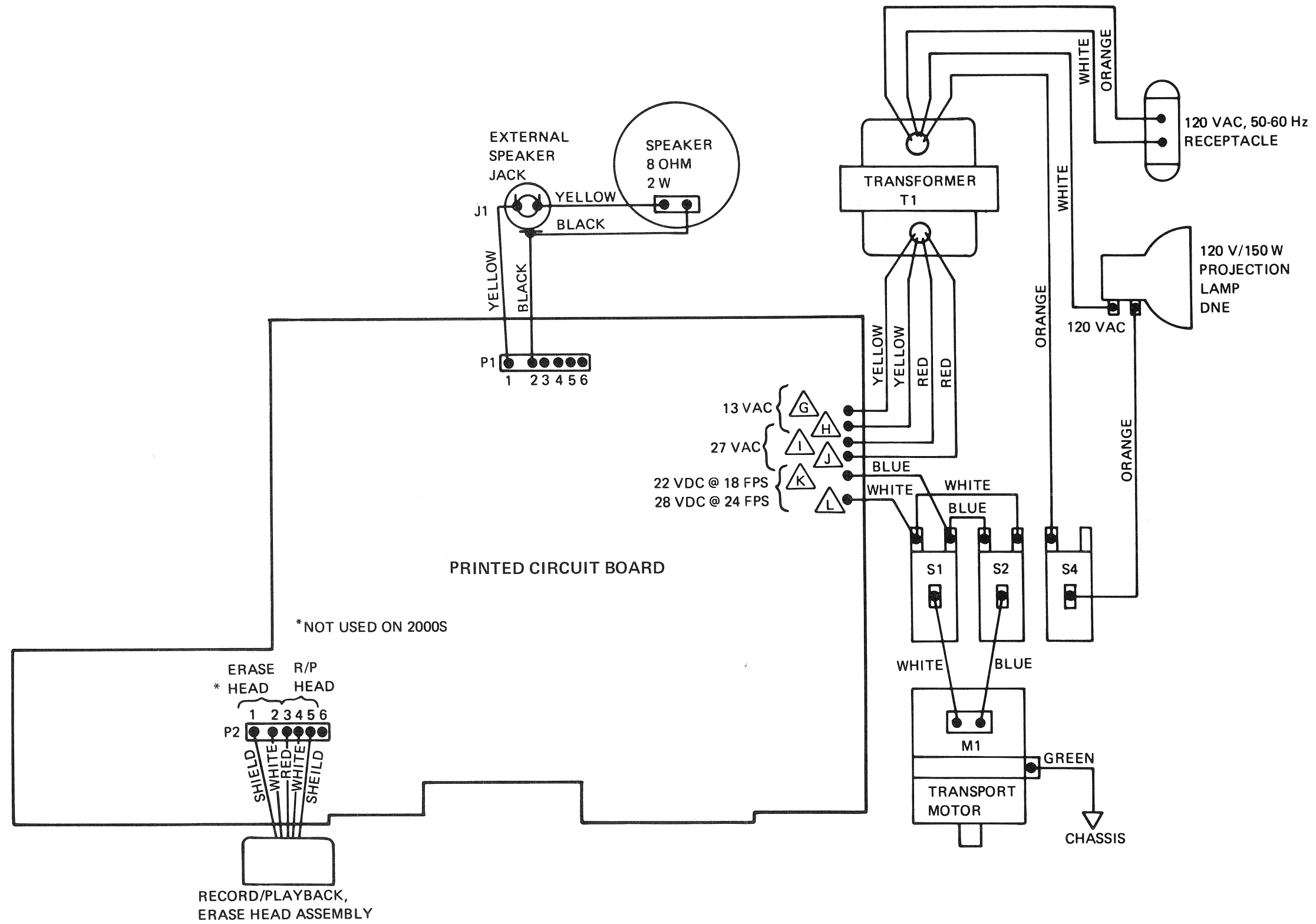

5.2 2000 S Block Diagram

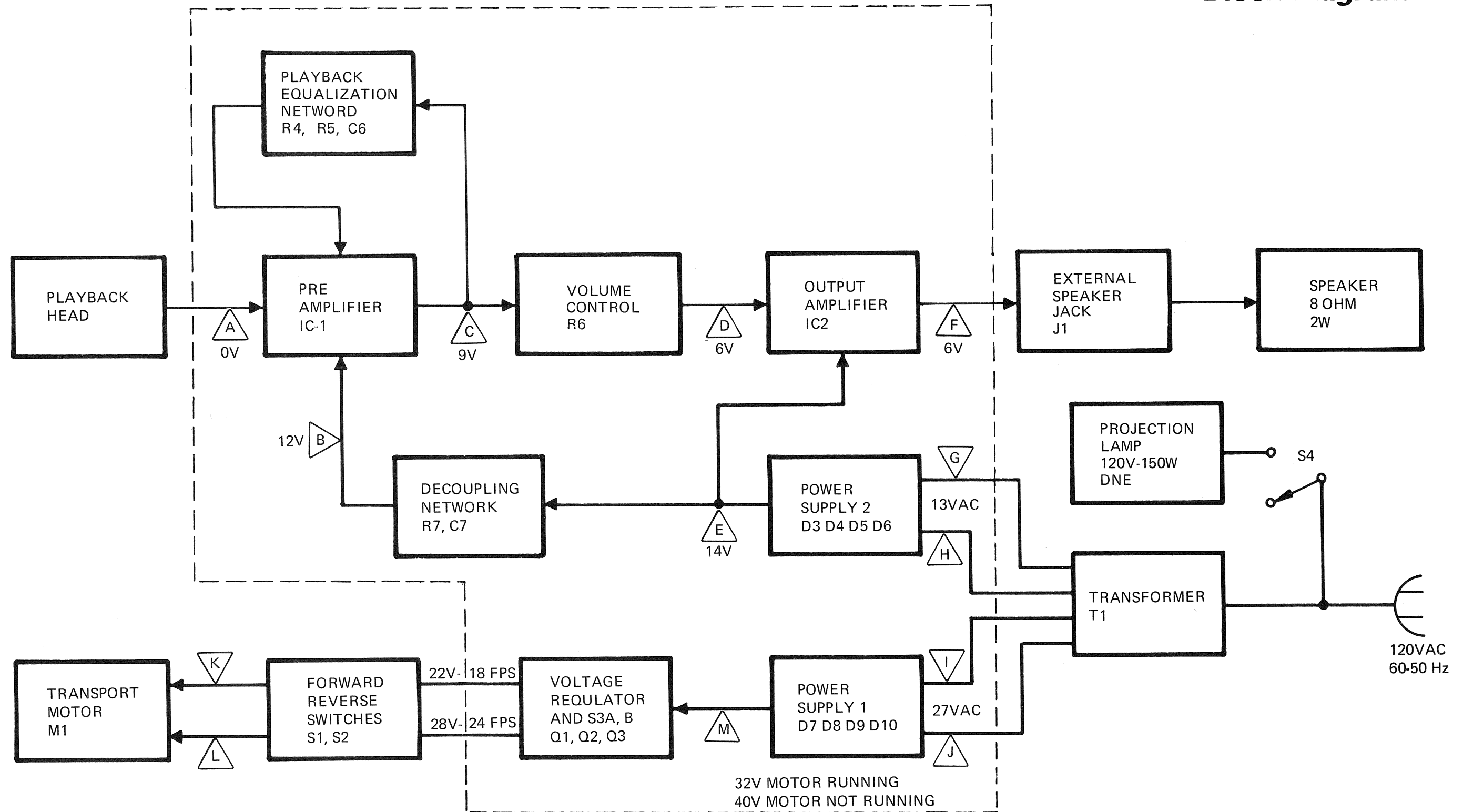

5.3 3000 S Block Diagram

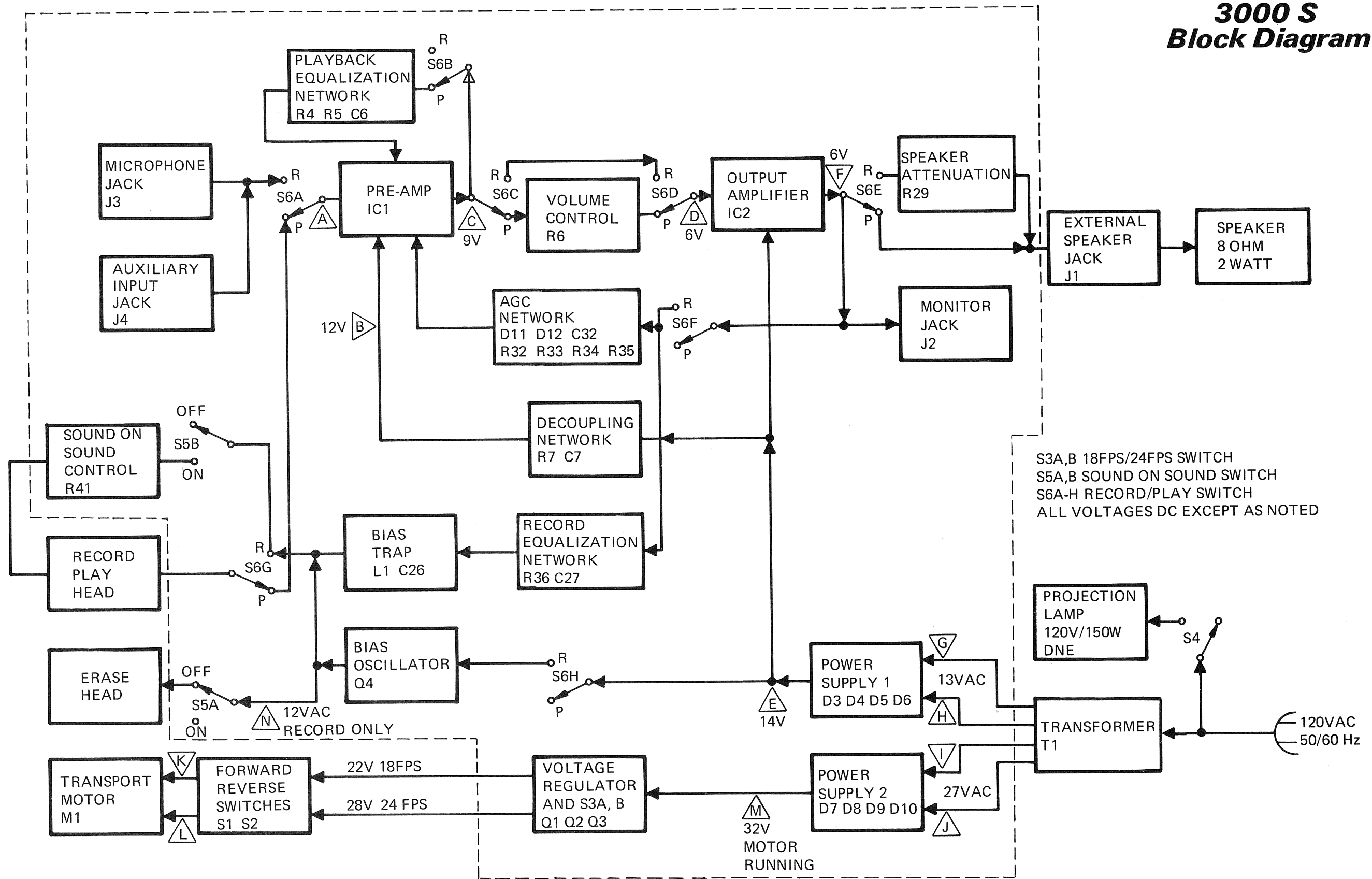

S3A,B 18FPS/24FPS SWITCH
 S5A,B SOUND ON SOUND SWITCH
 S6A-H RECORD/PLAY SWITCH
 ALL VOLTAGES DC EXCEPT AS NOTED

5.4 2000 S Schematic

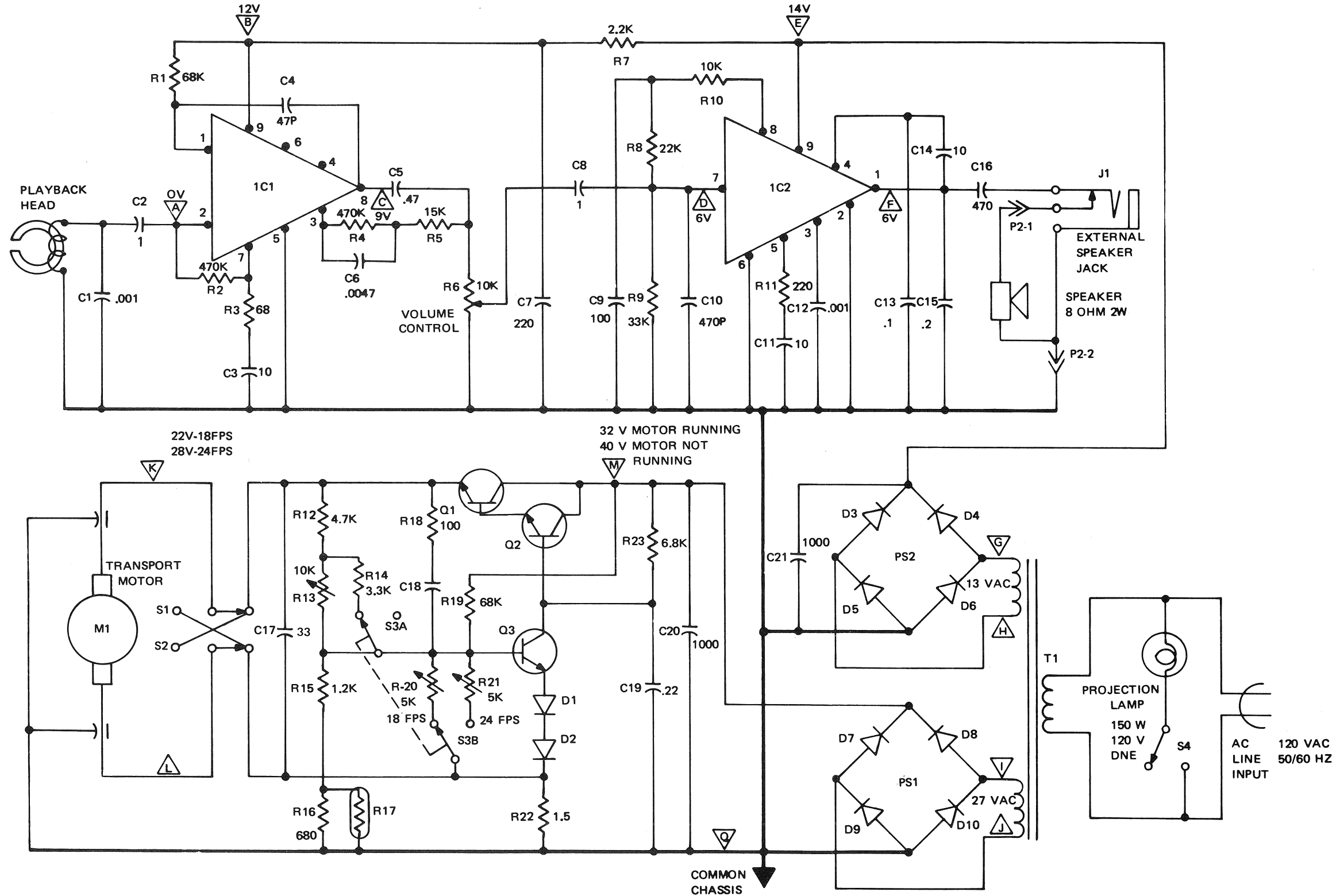

R20-18FPS SPEED ADJUST
 R21-24FPS SPEED ADJUST
 ALL RESISTANCE VALUES ARE IN OHMS.
 ALL CAPACITANCE VALUES ARE IN MICROFARADS.
 P = PICO-FARADS.
 ALL VOLTAGES DC EXCEPT AS NOTED.
 LAST NUMBERS USED R23
 C21
 D10

5.5 3000 S Schematic

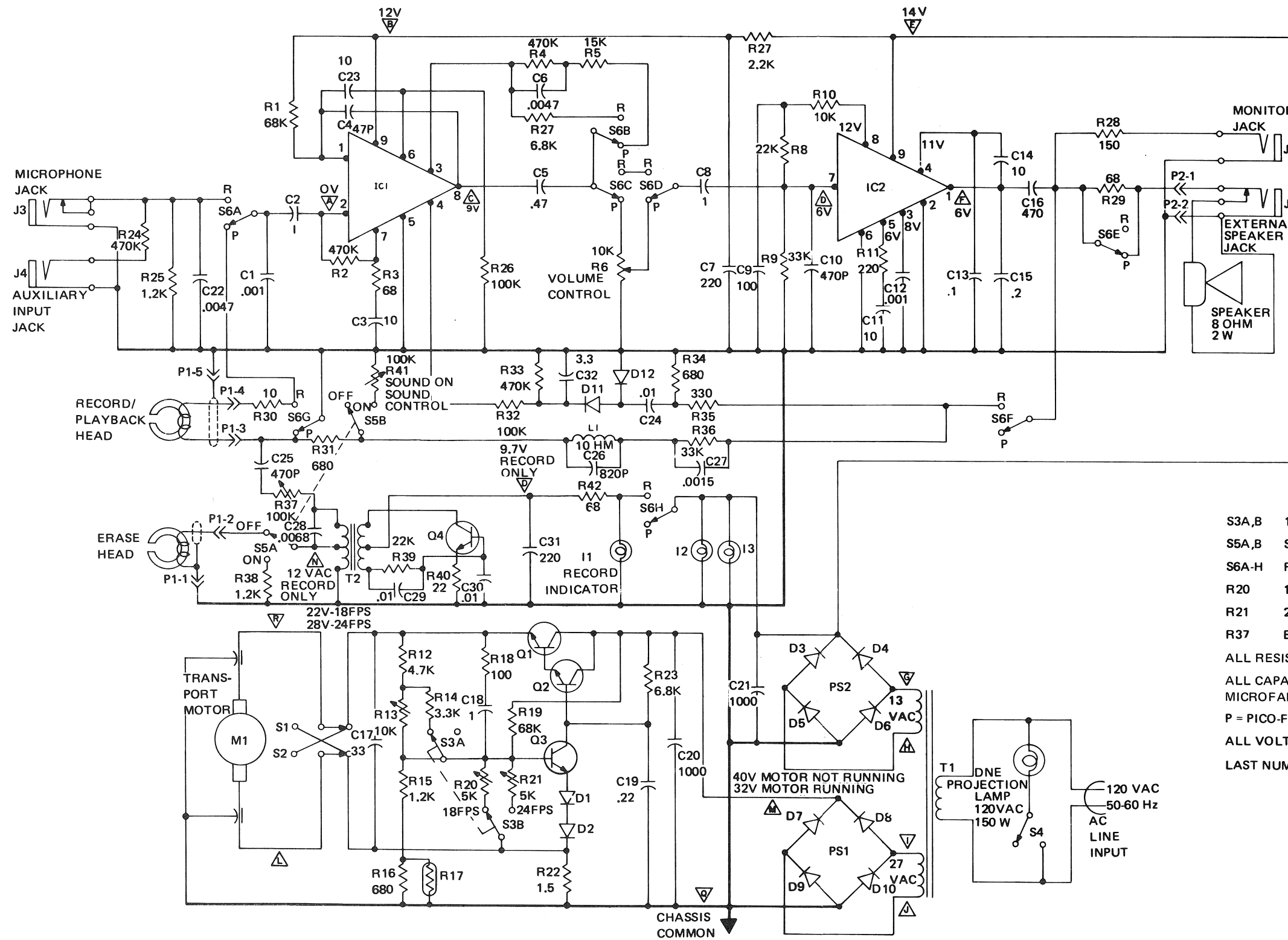

- S3A,B 18/24 FPS SWITCH
 - S5A,B SOUND ON SOUND SWITCH
 - S6A-H RECORD/PLAY SWITCH
 - R20 18 FPS ADJUST
 - R21 24 FPS ADJUST
 - R37 BIAS LEVEL ADJUST
- ALL RESISTANCE VALUES ARE IN OHMS.
 ALL CAPACITANCE VALUES ARE IN MICROFARADS.
 P = PICO-FARADS.
 ALL VOLTAGES DC EXCEPT AS NOTED.
- | | |
|-------------------|-----|
| LAST NUMBERS USED | R42 |
| | C31 |
| | D12 |
| | Q4 |

5.6 2000 S Circuit Board

J IS WIRE JUMPER
 R6 IS VOLUME CONTROL
 SW3A,B IS 18 FPS, 24 FPS SWITCH
 R20 IS 18 FPS ADJUSTMENT
 R21 IS 24 FPS ADJUSTMENT

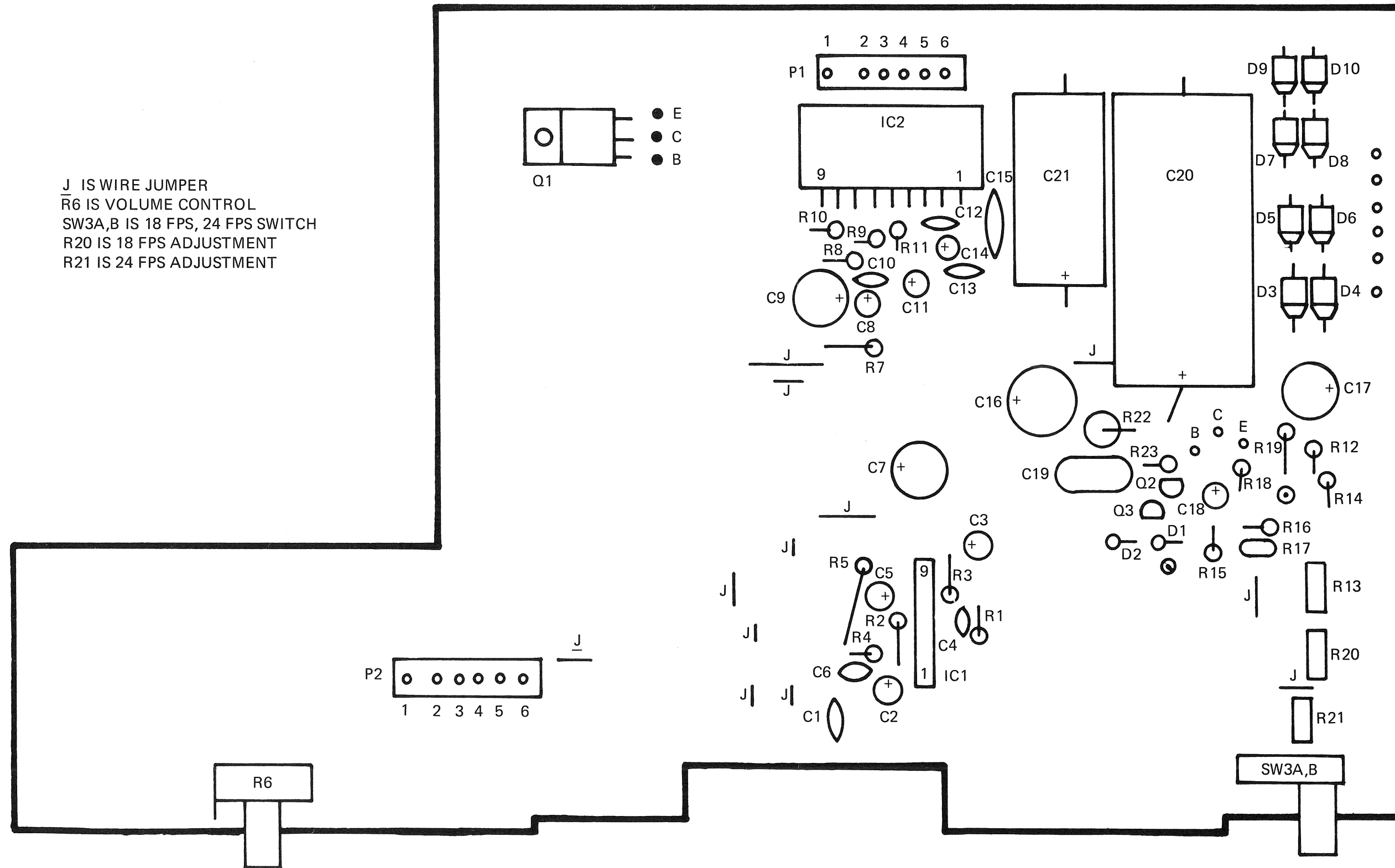

5.7 3000 S Circuit Board

J IS WIRE JUMPER
R6 IS VOLUME CONTROL
 R41 IS SOUND ON SOUND CONTROL
 S3A,B IS 18 FPS/24 FPS SWITCH
 S5A,B IS SOUND ON SOUND CONTROL
 S6A-H IS RECORD/PLAY SWITCH
 R20 IS 18 FPS ADJUST
 R21 IS 24 FPS ADJUST
 R37 IS BIAS LEVEL ADJUST

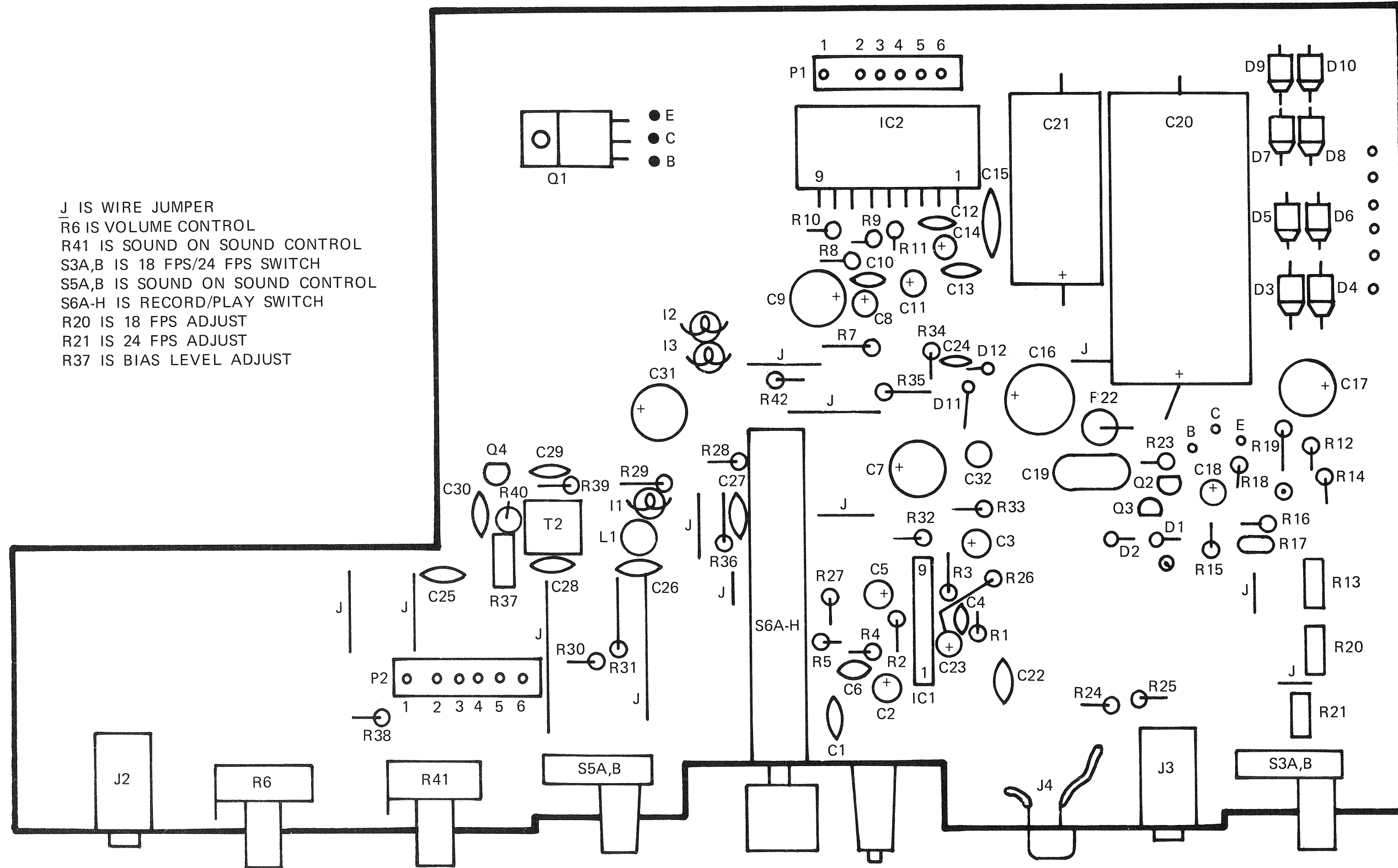

6.1 CONTROL KNOB MODE CHART—2000 S AND 3000 S**A. Control Knob in the OFF
Position:**

(Projector NOT Plugged IN)

1. Transformer OFF.
2. Amplifier OFF.
3. Motor OFF.
4. Lamp OFF.
5. Film guides in the RUN position.
6. Pressure plate bearing against the aperture plate.
7. Pressure pad retracted from the sound head.
8. Supply spindle in neutral.
9. Take-up spindle in neutral.

**B. Control Knob in the OFF
Position:**

(Projector Plugged In)

1. Transformer ON.
2. Amplifier ON.
3. Motor OFF.
4. Lamp OFF.
5. Film guides in the RUN position.
6. Pressure plate bearing against the aperture plate.
7. Pressure pad retracted from the sound head.
8. Supply spindle in neutral.
9. Take-up spindle in neutral.

**C. Control Knob in THREAD
Position:**

1. Transformer ON.
2. Amplifier ON.
3. Motor ON.
4. Lamp OFF.
5. Film guides in the LOOP-FORM position.
6. Pressure plate retracted from the aperture plate.
7. Pressure pad retracted from the sound head.
8. Supply spindle in neutral.
9. Take-up spindle driven.

**D. Control Knob in FORWARD
Position:**

1. Transformer ON.
2. Amplifier ON.
3. Motor ON.
4. Lamp ON.
5. Film guides in the RUN position.
6. Pressure plate bearing against the aperture plate.
7. Pressure pad bearing against the sound head.
8. Supply spindle in neutral.
9. Take-up spindle driven.

E. Control Knob in REWIND Position:

1. Transformer ON.
2. Amplifier ON.
3. Motor ON.
4. Lamp OFF.
5. Film guides in the LOOP-FORM position.
6. Pressure plate retracted from the aperture plate.
7. Pressure pad retracted from the sound head.
8. Supply spindle driven.
9. Take-up spindle in neutral.

F. Control Knob in the REVERSE Position:

1. Transformer ON.
2. Amplifier ON.
3. Motor ON.
4. Lamp ON.
5. Film guides in the RUN position.
6. Pressure plate bearing against the aperture plate.
7. Pressure pad retracted from the sound head.
8. Supply spindle driven.
9. Take-up spindle in neutral.

6.2 INSPECTION PROCEDURE

A. Film Transport

1. Place the projector in the THREAD mode and insert the end of a properly trimmed roll of Super 8 film into the projector. After approximately ten seconds the film should emerge and attach itself to the take-up reel.
2. Place the projector in the FORWARD mode and observe the projected image for the following:
 - a. The image should not be jumpy (claw).
 - b. If a line appears at the top or bottom of the picture, rotating the FRAMER should correct it. (framer)
 - c. The image should be sharp over the entire frame. (aperture and/or pressure plate)
3. Place the projector in the REVERSE mode and observe the projected image as described in 2A, 2B, and 2C.

B. Optical

1. Load the projector with a roll of film, place in the FORWARD mode, and observe the following:
 - a. Picture area is evenly illuminated. (lamp)
 - b. Picture frame does not change in size. (zoom lens)
 - c. Picture remains in sharp focus. (focus knob)
2. Place projector in the FORWARD mode with no film and observe the following:
 - a. Picture frame is not keystone. (aperture plate)
 - b. Picture frame is not ragged. (aperture plate)

C. Electrical

1. Lamp should light when the projector is in the FORWARD or REVERSE modes.
2. 3000 S ONLY. Control panel lights should come on when the projector is plugged in.
3. Projector should change speed as the 24-18 switch is moved.

D. Audio

2000 S Only

The 2000 S is checked using a 6500 Recorder Test Set and the prerecorded test film, tool NO. 2392.

SET-UP

1. Place the 6500 RECORD TYPE switch to the A position.
2. Insert the 6500 IN cable into the projector EXTERNAL SPEAKER jack.
3. Turn the 6500 TEST switch to the LEVEL 1 position and observe that the 6500 meter needle is in the green or upper yellow (-3 to +6 db) of the top scale.
4. Turn the 6500 TEST switch to the SET position and adjust the REFERENCE SET knob until the 6500 meter needle is centered within the SET marks on the top scale.

TESTS

1. Low Frequency (Low F) Test
Turn the 6500 TEST switch to the LOW F position. The meter needle should locate within the yellow or green areas on the top scale, but not past ± 6 db.
2. High Frequency (High F) Test
Turn the 6500 TEST switch to the HIGH F position. The meter needle should locate within the yellow or green areas on the top scale, but not past ± 6 db.

3. Flutter (Flut) Test
Turn the 6500 TEST switch to the FLUT position. The meter needle should locate within the green area of the bottom scale (0 - 0.6%).
4. Distortion (Dist) Test
Turn the 6500 TEST switch to the DIST position. The meter needle should locate within the green area of the bottom scale. (0 - 6%.)
5. Signal-to-Noise Ratio (SNR) Test
Turn the 6500 TEST to the SNR position. The meter needle should locate within the green area of the bottom scale. (Greater than -22 db.)

3000 S Only

The 3000 S is checked using a 6500 Recorder Test Set, and a Transport/Reproduction (T/R) unit.

SET-UP

1. Thread a fresh roll of unrecorded sound film onto the projector.
2. Set the projector 24-18 switch to the 18 position.
3. Set the projector SOUND-ON-SOUND switch to the OFF position.
4. Turn the 6500 RECORD TYPE switch to the A position.
5. Insert the 6500 OUT cable into the projector MIC receptacle.

RECORD PROCEDURE

The purpose of the record procedure is to feed a composite 200 Hz, 1,000 Hz, and 4,000 Hz audio signal, supplied by the 6500 Recorder Test Set, into the projector and record this signal on the film sound stripe.

1. Turn the 6500 unit ON.
2. Turn the 6500 TEST switch to the REC 1 position.
3. Set the 6500 OUT switch to the LINE position.
4. The 6500 REFERENCE SET control is not used and any setting is acceptable.

5. Set the projector to the FORWARD and RECORD modes.
6. Record approximately 40 feet of film and turn the projector OFF.
7. Rewind approximately 10 feet of film and turn the projector OFF.
8. Place the projector SOUND-ON-SOUND switch in the ON position.
9. Rotate the projector SOUND-ON-SOUND control knob fully clockwise.
10. Remove the 6500 OUT cable from the projector MIC receptacle.
11. Set the projector to the FORWARD and RECORD modes.
12. Voice record approximately 10 feet of film, then while the projector is running, move the SOUND-ON-SOUND switch to the OFF position.
13. Allow the remaining film to run through the projector, then rewind it on the supply reel.

PLAYBACK PROCEDURE

The recorded film will be played back on the T/R unit and evaluated by the 6500 Test Set.

SET-UP

1. Mount the recorded film on the T/R unit supply spindle.
2. Remove the T/R unit sound head pressure pad assembly.
3. Thread the film through the sound head and attach it to the take-up reel.
4. Install the sound head pressure pad assembly.
5. Activate the T/R unit by depressing the square button marked STOP.
6. Depress the T/R unit PLAY button and make the following two adjustments.

a. Level 1 Adjust

Turn the 6500 TEST switch to the LEVEL 1 position and turn the T/R unit REPRO LEVEL control until the 6500 meter needle locates within the SET markings. The monitor headset

volume can be adjusted by turning the T/R unit VOLUME control.

b. Set Adjust

Turn the 6500 TEST switch to the SET position. Adjust the 6500 REFERENCE SET control until the 6500 meter needle locates within the SET markings.

TESTS

1. Low Frequency (Low F) Test
Turn the 6500 TEST switch to the LOW F position. The meter needle should locate within the yellow or green areas on the top scale (± 6 db).
2. High Frequency (High F) Test
Turn the 6500 TEST switch to the HIGH F position. The meter needle should locate within the yellow or green areas on the top scale, but not past ± 6 db.
3. Flutter (Flut) Test
Turn the 6500 TEST switch to the FLUT position. The meter needle should locate within the green area of the bottom scale (0 - 0.6%).
4. Distortion (Dist) Test
Turn the 6500 TEST switch to the DIST position. The meter needle should locate within the green area of the bottom scale. (0 - 6%.)
5. Sound-On-Sound Test
Turn the 6500 TEST switch to the LEVEL 1 position. The meter needle should locate within the SET markings. When the remainder of the 30 feet of film with the composite signal has been transported, the 6500 meter needle should move into the red area of the top scale and remain there until the 10 feet of film with the sound-on-sound signal is transported. Then, the needle should move to the left side of the scale as film with no recorded signal moves past the sound head.
6. Signal-to-Noise Ratio (SNR) Test
As soon as the 6500 meter needle moves to the left in the previous test, turn the

6500 TEST switch to the SNR position. The meter needle should locate within the green area of the bottom scale.

7. Projector Speed Test
 - a. Rewind and rethread the film on the T/R unit.
 - b. Turn the 6500 TEST switch to the LEVEL 1 position.
 - c. Place the T/R unit in the PLAY mode.
 - d. Observe the Frequency Counter digital readout. The reading must be between 970 (too fast) and 1,030 (too slow). 1000 is the nominal reading.

MICROPHONE TEST (3000 S ONLY)

1. Insert the microphone plug into the projector MIC receptacle.
2. Place the projector in the RECORD mode.
3. Insert the 6500 IN cable into the projector MON receptacle.
4. Turn the 6500 TEST switch to the LEVEL 1 position.
5. Speak loudly into the microphone. The 6500 meter needle should locate in the green area on the top scale.

6.3 TROUBLESHOOTING CHART

Use the troubleshooting chart as the starting point for problem diagnosis. The page references in the Remedy column indicate the specific page

on which service information for the particular component or feature is contained.

A. PROJECTOR COMPLETELY INOPERATIVE

SYMPTOM	CAUSE	REMEDY
Projector inoperative.	Power cord defective. Projector cord receptacle defective. Cord receptacle to transformer wires disconnected or broken. Transformer defective.	Replace cord. Replace receptacle. Replace wires. See transformer, page 4–15.

B. FILM TRANSPORT

SYMPTOM	CAUSE	REMEDY
Film jams at aperture.	Claw not properly adjusted or broken.	See claw, page 4–2.
Film jams at pressure roller.	Pressure roller not adjusted properly.	See capstan/pressure roller, page 4–1.

SYMPTOM	CAUSE	REMEDY
Film jams at rear sprocket.	Lower film guide not adjusted properly.	See film path, page 4–4.
Film does not attach itself to take-up reel.	Leader has excessive curl.	Replace leader. No projector adjustment possible.
Film jumps.	Loose claw cam on shutter.	See shutter, page 4–13.
Inadequate frame adjustment.	Framer out of adjustment.	See claw/framer, page 4–2.
Film buzz and/or vibration.	Pressure plate defective.	See aperture/pressure plate, page 4–12.
Supply spindle driven in FORWARD mode.	Gear selector arm caught on top of supply spindle gear.	See drive train, page 4–6.
Excessive noise in REWIND mode.	Gear selector arm rubbing on back of supply spindle gear.	See drive train, page 4–6.
Excessive noise in FORWARD mode.	Bearings vibrating or idler gear plate improperly adjusted.	See drive train, page 4–6.

C. AUDIO

SYMPTOM	CAUSE	REMEDY
No sound.	IC-2 defective. Wires to auxilliary speaker jack and/or speaker disconnected or broken. Speaker defective. IC-2 defective.	Replace. Check and replace. See speaker, page 4–16. Replace.
Distorted sound.	Sound head pressure plate improperly adjusted. Dirty capstan, pressure roller, or sound head. Flywheel not turning freely. Transport speed incorrect.	See film path, page 4–4. Clean. See film path, page 4–4. See motor, page 4–14.
Noise or static in sound.	Defective volume control potentiometer. Bad contact on connector P1.	Replace. Clean or replace as necessary.
Low audio output.	Defective sound head pressure pad. Dirty or defective sound head.	Replace. Clean or replace as necessary.

SYMPTOM	CAUSE	REMEDY
Frequency response out of specification.	Dirty sound head.	Clean.
3000 S ONLY No record, playback okay.	Defective microphone. Defective bias oscillator.	Replace. Check Q4, replace if defective.

D. OPTICAL

SYMPTOM	CAUSE	REMEDY
Aperture unevenly illuminated.	Defective lamp or lamp socket alignment.	See lamp, page 4-11.
Aperture keystone shaped.	Aperture plate improperly adjusted.	See aperture/pressure plate, page 4-12.
Zoom lens hard to focus or jumps when focused.	Focus knob binding in slot in lens.	See zoom lens, page 4-13.
Blurry pictures.	Zoom lens defective. Pressure plate profile incorrect.	Replace lens. See aperture/pressure plate, page 4-12.

E. ELECTRICAL

SYMPTOM	CAUSE	REMEDY
No rewind.	Switch No. 1 defective or not adjusted properly.	See snap-action switch cluster, page 4-15.
No forward.	Switch No. 2 defective or not adjusted properly.	See snap-action switch cluster, page 4-15.
Motor will not run.	Defective transformer. Defective transistor.	See block diagram, page 5-5, or 5-7. See block diagram, page 5-5, or 5-7.
Motor speed out of specification.	Excessive friction in drive train. Speed adjust potentiometer improperly adjusted. Motor voltage supply circuit.	See drive train, page 4-6. See motor, page 4-14. See block diagram, page 5-5, or 5-7.

SYMPTOM	CAUSE	REMEDY
Motor speed out of specification. (Continued)	Check R-22, D-1, D-2, Q-1, Q-2, and Q-3. Shorted speed adjustment potentiometers.	Replace defective components. Replace.
Motor buzz.	Bad brush contact.	See motor, page 4–14.
Projector lamp does not light.	Switch S4 defective. Defective lamp. Defective wire in lamp circuit.	See snap-action switch cluster, page 4–15. Replace. Check and replace.

This section contains additional service information which supplements and updates the main text. Consult the following pages for the latest data and/or procedures for servicing this equipment. Insert new supplements when received.



2000 S
3000 S

Supplement No.1

Date: 7/30/76 (Revised)

SUPPLEMENT TO SERVICE MANUAL 125-881

ALL MODELS

IN-PROCESS MODIFICATIONS

Several in-process modifications have been made to these projectors at the factory. Some were made to increase the number of features and others were made to improve performance levels.

The following descriptions of these modifications include the part numbers and descriptions for all parts involved in the modifications, both old and new.

The following information is given primarily to facilitate the ordering of spare parts and it is NOT necessary to perform all modifications on all projectors received. Make modifications ONLY to defective mechanisms.

MODIFICATION NO. 1

SELF THREADING

Changes in the self threading mechanism have been made to help eliminate film jamming when the projector is threaded while in the FORWARD position. When the new parts are installed, the projector will not thread in the FORWARD position. The new parts are interchangeable with the old parts. All of the new parts must be used when making this modification.

OLD NO.	NEW NO.	DESCRIPTION
881-897	881-057	GUIDE, FILM FEED
881-850	881-041	GUIDE, FRONT, UPPER
N.A.	881-036	FILM STOPPER
N.A.	881-037	PIN
881-852	881-092	SPRING, FRONT GUIDE
881-848	881-058	BRACKET, FILM FEED GATE

MODIFICATION NO. 2

FILM PATH (ACTUATOR ARM)

Some projectors have a narrow film path between the aperture and pressure plates. In the REWIND mode, the film may come into contact with the film claw, causing sprocket hole damage. The diameter of the actuator Arm guide has been increased to cause a wider film path when the projector is in the REWIND mode. The new part is interchangeable with the old part.

OLD NO.	NEW NO.	DESCRIPTION
881-899	881-043	GUIDE, ACTUATOR ARM

MODIFICATION NO. 3

FOCUS KNOB ASSEMBLY

The diameter of the focus knob has been increased from 16mm to 26mm. This change will increase ease of focusing. All new parts must be used when performing this modification.

OLD NO.	NEW NO.	DESCRIPTION
881-869	881-049	KNOB, FOCUS
881-500	881-050	HOUSING, FRONT
N.A.	881-051	TRIMPLATE, FOCUS KNOB

MODIFICATION NO. 6**SUPPLY SPINDLE**

The supply spindle and pulley have been changed to maintain uniformity between the supply and take-up spindles. The large spindle and pulley is used on projectors with the 600 foot capacity reel.

OLD NO.	NEW NO.	DESCRIPTION
881-514	881-583	SPINDLE, SUPPLY ARM
881-513	881-582	PULLEY

MODIFICATION NO. 7**CONTROL CAM**

On some early models, the CONTROL KNOB can be set anywhere between the detent positions. An improper setting will cause jamming and film damage, particularly if the CONTROL KNOB is set between OFF and THREAD. The new control cam has more positive detents and should help eliminate this type of problem.

OLD NO.	NEW NO.	DESCRIPTION
881-828	881-055	CAM, CONTROL, LARGE

MODIFICATION NO. 8**REWIND BELT**

The rewind belt has been lengthened from 270mm to 282mm to reduce excess torque in the REWIND position.

OLD NO.	NEW NO.	DESCRIPTION
881-883	Same	BELT, REWIND



2000 S
3000 S

Supplement No. 2

Date: 10/1/76

SUPPLEMENT TO SERVICE MANUAL 125-881

Later model projectors are equipped with a speed control which is located on the control panel, above the FPS selector switch.

This control permits the operator to vary the projector transport speed and match the speed at which the film was recorded, insuring proper playback.

Component locations and ratings are illustrated on the revised pages 5-9A, 5-11A, 5-13A, and 5-15A.

Refer to the illustrated sound projector parts manual for spare part information.

5.4 2000 S Schematic

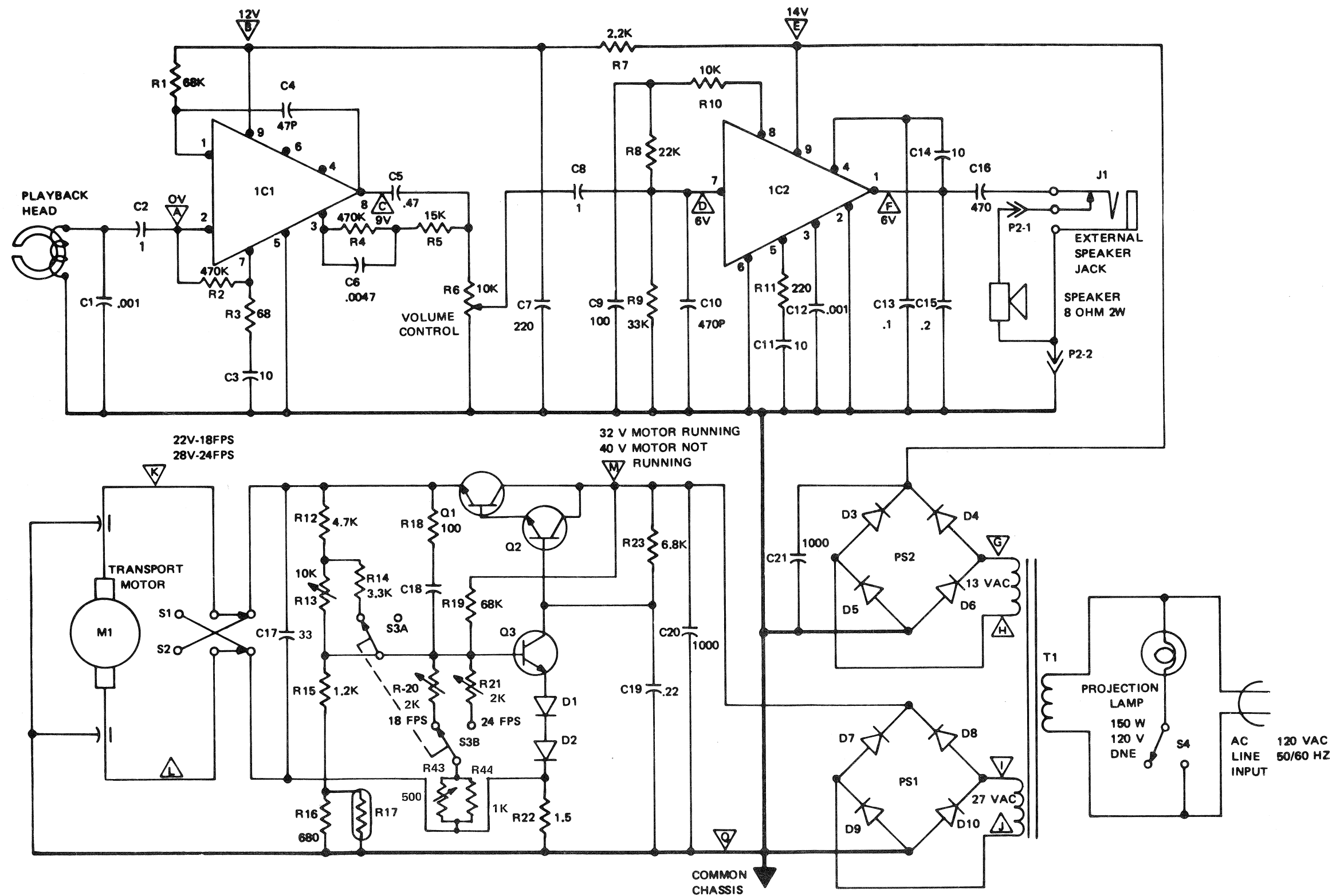

NOTE: EARLY MODELS WERE
18 FPS ONLY
R20-18FPS SPEED ADJUST
R21-24FPS SPEED ADJUST
ALL RESISTANCE VALUES ARE IN OHMS.
ALL CAPACITANCE VALUES ARE IN
MICROFARADS.
P = PICO-FARADS.
ALL VOLTAGES DC EXCEPT AS NOTED.

C21
D10

5.5 3000 S Schematic

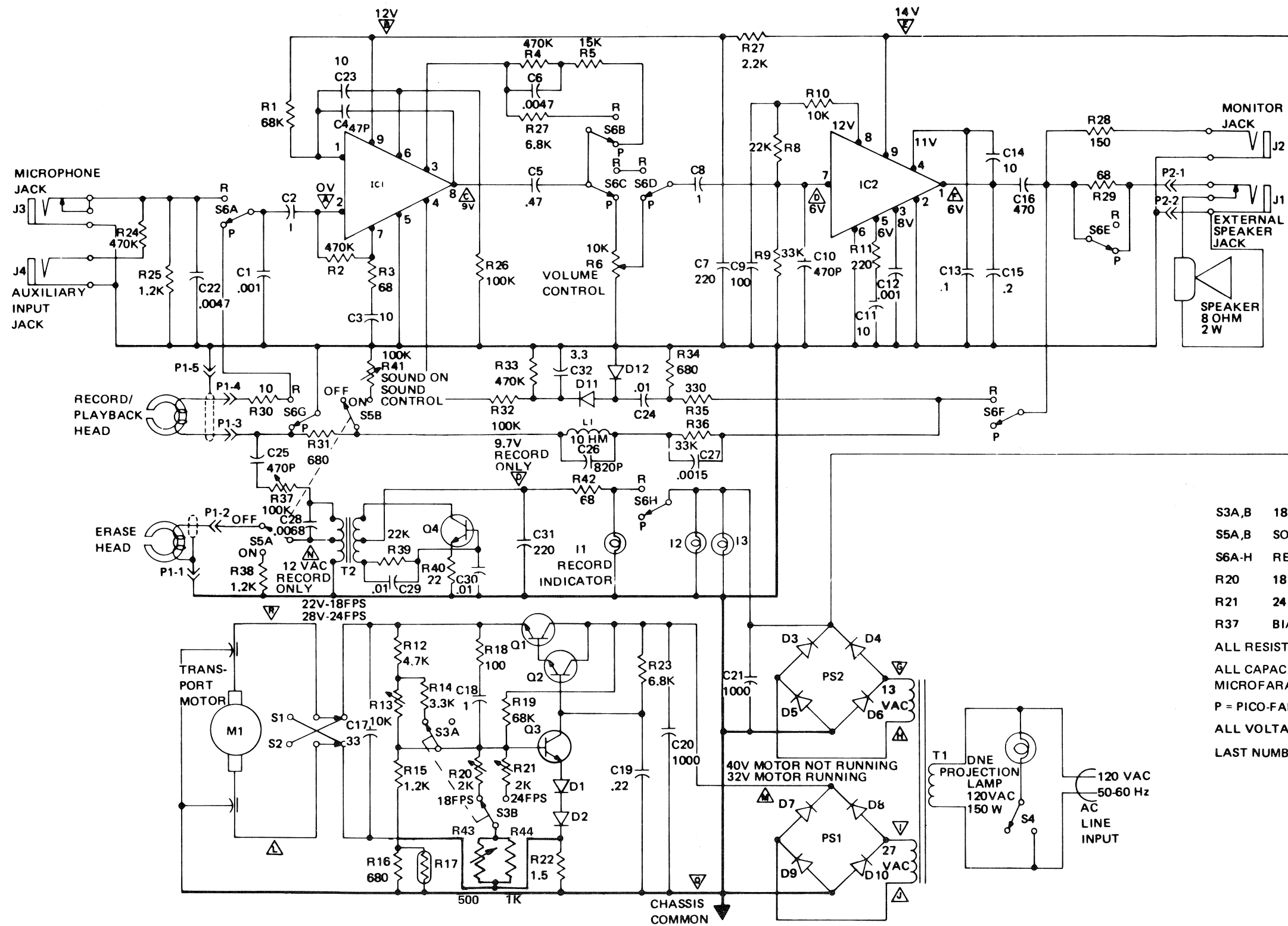

- S3A,B 18/24 FPS SWITCH
- S5A,B SOUND ON SOUND SWITCH
- S6A-H RECORD/PLAY SWITCH
- R20 18 FPS ADJUST
- R21 24 FPS ADJUST
- R37 BIAS LEVEL ADJUST

ALL RESISTANCE VALUES ARE IN OHMS.
ALL CAPACITANCE VALUES ARE IN MICROFARADS.

P = PICO-FARADS.

ALL VOLTAGES DC EXCEPT AS NOTED.

- | | |
|-------------------|-----|
| LAST NUMBERS USED | R44 |
| | C31 |
| | D12 |
| | Q4 |

5.6 2000 S Circuit Board

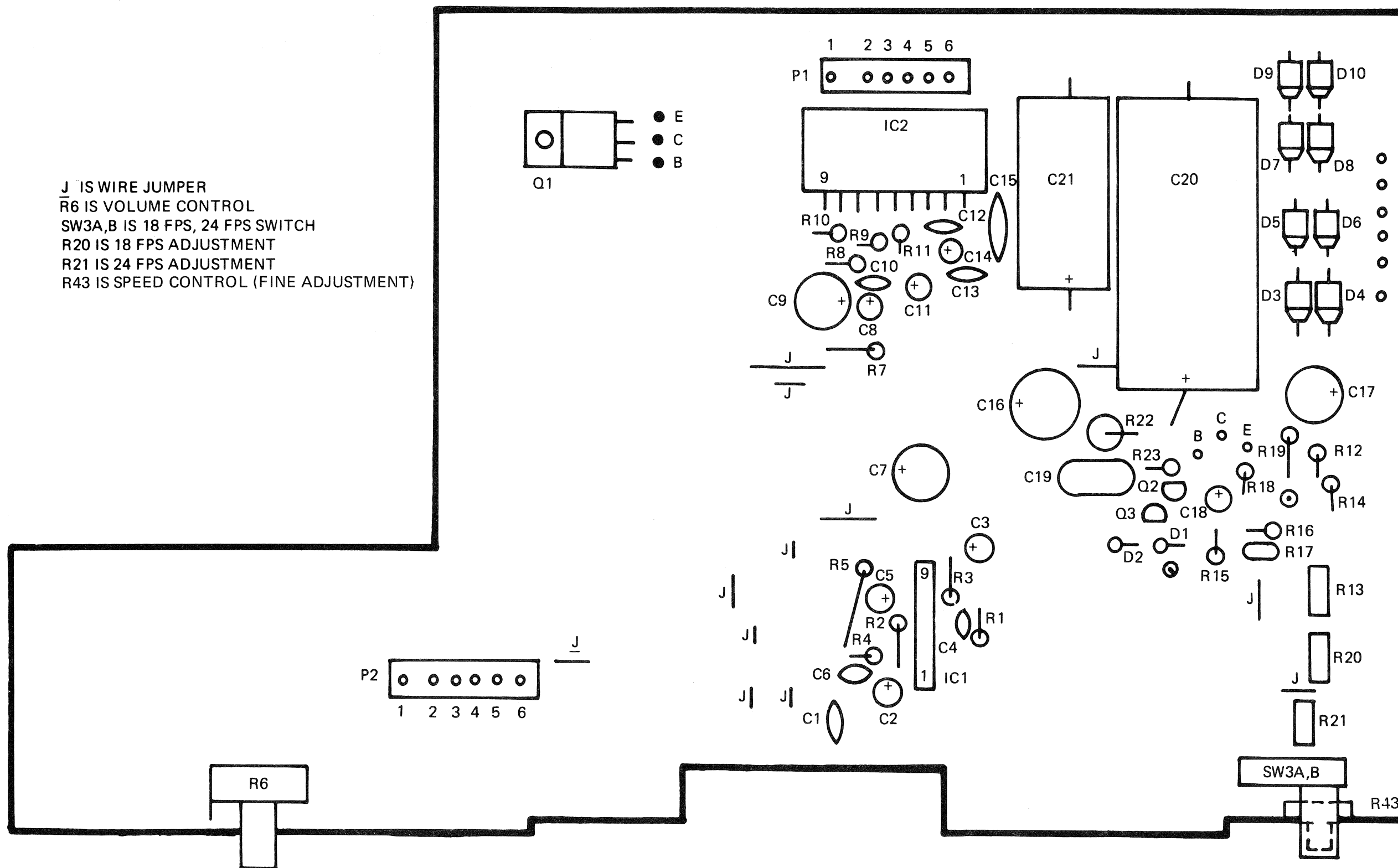

5.7 3000 S Circuit Board

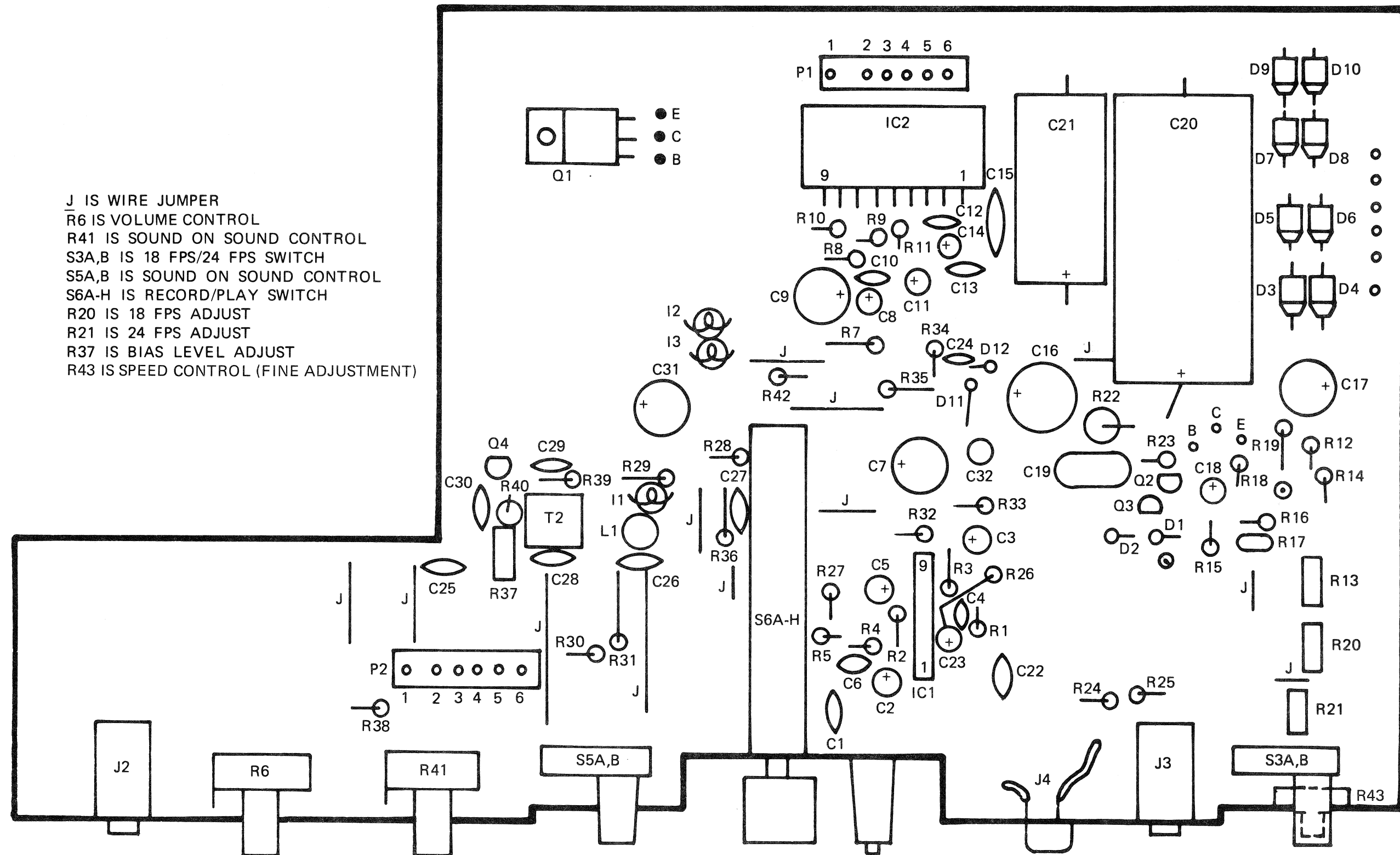



2000S, 3000.S
AND 3100S

Supplement No. 3

Date: 4/1/77

SUPPLEMENT TO SERVICE MANUAL 125-881

MODEL 3100S ONLY

The 3100S is similar to the 3000S. The major differences are the number of features and the electronic circuitry.

This supplement contains service data pertaining to the 3100S only and information not presented here can be found in the Service Manual under the corresponding heading for the 3000S.

All information currently available for the 3100S is contained in this supplement which will be revised and expanded if any additional data becomes available.

The relationship of the motor and its control circuits to the other elements of the electrical system is illustrated in the block diagram.

FUNCTION TEST

1. Motor Current Draw

- a. Connect a DC ammeter in series with the motor.
- b. Turn the projector to the FORWARD mode and note the ammeter reading. It should be between 550 and 700 milliamperes.

2. Motor Voltage Regulator Power Supply

- a. Connect a DC voltmeter across C41 1000uf capacitor on the amplifier circuit board.
- b. Turn the projector to the FORWARD mode and note the voltmeter reading. It should be $30 \text{ VDC} \pm 20\%$ with the motor running.

3. Motor Voltage Regulator

- a. Connect a DC voltmeter across the blue and white wires on top of the snap-action switches 56 and 57.
- b. Set the FRAMES-PER-SECOND selector switch to 18.
- c. Turn the projector to the FORWARD mode and note the voltmeter reading. It should be $20 \text{ VDC} \pm 20\%$.
- d. Set the 24-18 selector switch to 24.
- e. Note the voltmeter reading. It should be $25 \text{ VDC} \pm 20\%$.

ADJUSTMENTS

Excessive current draw can be caused by high friction in the drive train or poor motor brush contact. Brush contact is adjusted by removing the brush and filing the end to the proper contour with a round file.

1. Motor (18 and 24 FPS) Speed Adjustment

- a. Remove front housing.
- b. Locate the access slot for the speed adjustment variable resistors.
- c. Set the 24-18 selector switch to 18 and turn the projector to the FORWARD mode.
- d. Connect the Light Pulse Detector to the Frequency Counter.
- e. Place the sensor of the Light Pulse Detector in line with the projection lamp and adjust the Frequency Counter sensitivity to obtain a reading.
- f. Adjust the 18 FPS variable resistor until a reading of 54 cps is obtained.
- g. Set the 24-18 selector switch to 24.
- h. Adjust the 24 FPS variable resistor until a reading of 72 cps is obtained.

The relationship of the record and reproduction system to the other elements of the electrical system is illustrated by the block diagram. The record and reproduction system consists of the following major components:

1. Record/Reproduce Head
2. Amplifier Circuit Board
3. Speaker

FUNCTION TEST

1. Amplifier and Bias Oscillator Power Supply
 - a. Connect a DC voltmeter across C34 on the amplifier circuit board.
 - b. The meter should read 36 VDC \pm 20%.
2. Speaker Windings
 - a. Using a VOM set to X1, place the meter leads to the speaker terminals.
 - b. The resistance reading should be 16 ohms \pm 10%.
3. Record/Reproduce Head
 - a. Using a VOM set to X10, place the meter leads to pin 3 and 4 of connector P2.
 - b. The resistance reading should be 250 ohms \pm 10%.
4. Erase Head
 - a. Using a VOM set to X1, place the meter leads to pin 1 and 2 of connector P2.
 - b. The resistance reading should be 4 ohms \pm 10%.
5. Bias Oscillator
 - a. Connect an AC voltmeter between pins 1 and 2 of connector P2.
 - b. With the projector in the RECORD mode and the Sound on Sound switch in the normal (off) position, the meter reading should be 15 VAC \pm 20%.
6. Bias Voltage at the Record/Reproduce Head
 - a. Connect an AC voltmeter between pins 3 and 4 of connector P2.
 - b. With the projector in the RECORD mode and no audio input, the meter reading should be 15 VAC \pm 10%.

ADJUSTMENTS

1. Bias Voltage at the Sound Head Adjustment
 - a. Connect an AC voltmeter to pins 3 and 4 of connector P2.
 - b. Place the projector in the RECORD mode with no audio input.

1. Bias Voltage at the Sound Head Adjustment (Continued)

- c. The meter should read 15 VAC \pm 10%.
- d. If the voltage reading is not 15 VAC, adjust the potentiometer R38 until the correct reading is obtained.

2. Sound Head Alignment

- a. Thread a roll of prerecorded film containing a 1000 Hz signal through the projector, (or a prerecorded signal from the 6500 Recorder Test Set.)
- b. Connect an audio voltmeter to the External Speaker receptacle on the projector.
- c. Place the projector in the FORWARD mode and note the meter reading.
- d. Using the projector Volume control, adjust the audio output until the meter reads approximately center scale.
- e. Turn the adjusting screws on the sound head, alternately, until the highest possible meter reading is obtained.

3. Audio System Check Test

The 3100S is checked using a 6500 Recorder Test Set, and a Transport/Reproduction (T/R) unit.

Set Up:

- a. Thread a fresh roll of unrecorded sound film onto the projector.
- b. Set the projector 24-18 FPS switch to the 18 FPS position.
- c. Set the projector Sound on Sound switch to the normal (off) position.
- d. Turn the 6500 Record Type switch to the A position.
- e. Insert the 6500 OUT cable into the projector MIC receptacle.

4. Record Procedure

The purpose of the record procedure is to feed a composite 200 Hz, 1000 Hz and 4000 Hz audio signal, supplied by the 6500 Recorder Test Set, into the projector and record this signal on the film sound stripe.

- a. Turn the 6500 unit ON. Turn the 6500 Test switch to the REC1 position.
- b. Set the 6500 OUT switch to the Line position.
- c. The 6500 Reference Set control is not used and any setting is acceptable.
- d. Set the projector to the FORWARD and RECORD modes.
- e. Record approximately 40 feet of film and turn the projector OFF.
- f. Rewind approximately 10 feet of film and turn the projector OFF.
- g. Place the projector Sound on Sound switch in the ON position fully clockwise.
- h. Remove the 6500 OUT cable from the projector MIC receptacle.
- i. Set the projector to the FORWARD and RECORD modes.
- j. Voice record approximately 10 feet of film, then while the projector is running move the Sound on Sound switch to the normal (off) position and remove the microphone from the MIC receptacle.
- k. Allow the remaining film to run through the projector, then rewind it on the supply reel.

5. Playback Procedure

The recorded film will be played back on the T/R unit and evaluated by the 6500 Test Set.

Set Up:

- a. Mount the recorded film on the T/R unit supply spindle.
- b. Remove the T/R unit sound head pressure pad assembly.
- c. Thread the film through the sound head and attach it to the take-up reel.
- d. Install the sound head pressure pad assembly.
- e. Activate the T/R unit by depressing the square button marked STOP.
- f. Depress the T/R unit PLAY button and make the following two adjustments.

(1) Level 1 Adjust

Turn the 6500 Test switch to the LEVEL 1 position and turn the T/R unit Repro Level control until the 6500 meter needle locates within the Set markings. The monitor headset volume can be adjusted by turning the T/R unit Volume control.

(2) Set Adjust

Turn the 6500 Test switch to the Set position. Adjust the 6500 Reference Set control until the 6500 meter needle locates within the Set markings.

6. Tests:

- a. Low Frequency (Low F) Test
Turn the 6500 Test switch to the LOW F position. The meter needle should locate within the yellow or green area on the top scale (+ 6 db).
- b. High Frequency (High F) Test
Turn the 6500 Test switch to the HIGH F position. The meter needle should locate within the yellow or green areas on the top scale, but not past + 6 db.
- c. Flutter (Flut) Test
Turn the 6500 Test switch to the FLUT position. The meter needle should locate within the green area of the bottom scale (0 - 0.6%).
- d. Distortion (Dist) Test
Turn the 6500 Test switch to the DIST position. The meter needle should locate within the green area of the bottom scale (0-6%).
- e. Sound-On-Sound Test
Turn the 6500 Test switch to the Level 1 position. The meter needle should locate within the Set markings. When the remainder of the 30 feet of film with the composite signal has been transported, the 6500 meter needle should move into the red area of the top scale and remain there until the 10 feet of film with the sound on sound signal is transported. Then, the needle should move to the left side of the scale as film with no recorded signal move past the sound head.

6. Tests: (Continued)

- f. Signal-to-Noise Ratio (SNR) Test
As soon as the 6500 meter needle moves to the left in the previous test, turn the 6500 Test switch to the SNR position. The meter needle should locate within the green area of the bottom scale.
- g. Projector Speed Test
 - (1) Rewind and rethread the film on the T/R unit.
 - (2) Turn the 6500 Test switch to the LEVEL 1 position.
 - (3) Place the T/R unit in the PLAY mode.
 - (4) Observe the Frequency Counter digital readout. The reading must be between 970 (too fast) and 1,020 (too slow). 1000 is the nominal reading.
- h. Microphone Test
 - (1) Insert the microphone plug into the projector MIC receptacle.
 - (2) Place the projector in the RECORD and MANUAL mode.
 - (3) Turn the Volume control about halfway and speak loudly into the microphone. Note that the Record Level meter needle should move to the right.
- i. Audio System Test
This test is used to check the audio path through the projector. In this test a microphone, projector and signal tracer are used.
 - (1) Place the projector in the RECORD mode with Volume control about halfway.
 - (2) Turn the Signal Tracer on and place the braided lead from the probe to common.
 - (3) Place the Signal Tracer Level control on 35.
- j. Input
 - (1) Place the Signal Tracer probe on TP-A (Pin 2, IC1) and speak loudly into the microphone.
 - (2) If voice is heard, the input and microphone are good.
- k. Integrated Circuit No. 1 (IC1)
 - (1) Place the Signal Tracer probe on TP-C (Pin 8, IC1) and speak loudly into the microphone.
 - (2) If voice is heard, IC1 is good.
- l. Amplifier and Impedance Converter
 - (1) Place the Signal Tracer probe on TP-E and speak loudly into the microphone.
 - (2) If voice is heard, then Q1 and Q2 are good.
- m. Muting Switch
 - (1) Place the Signal Tracer probe on TP-G (Pin 8, IC2) and speak loudly into the microphone.
 - (2) If no voice is heard, the muting switch is either loose or defective.
- n. Output Amplifier
 - (1) Place the Signal Tracer probe on TP-I (Pin 14, IC2), and speak loudly into the microphone.
 - (2) If voice is heard, IC2, Q3 and Q4 are good.
- o. Record Equalization Network and Bias Trap
 - (1) Place the Signal Tracer probe on Pin 3 of connector P2 and speak loudly into the microphone.
 - (2) If voice is heard then L2, C25, C26, R47 are good.

3100 S Wiring Diagram

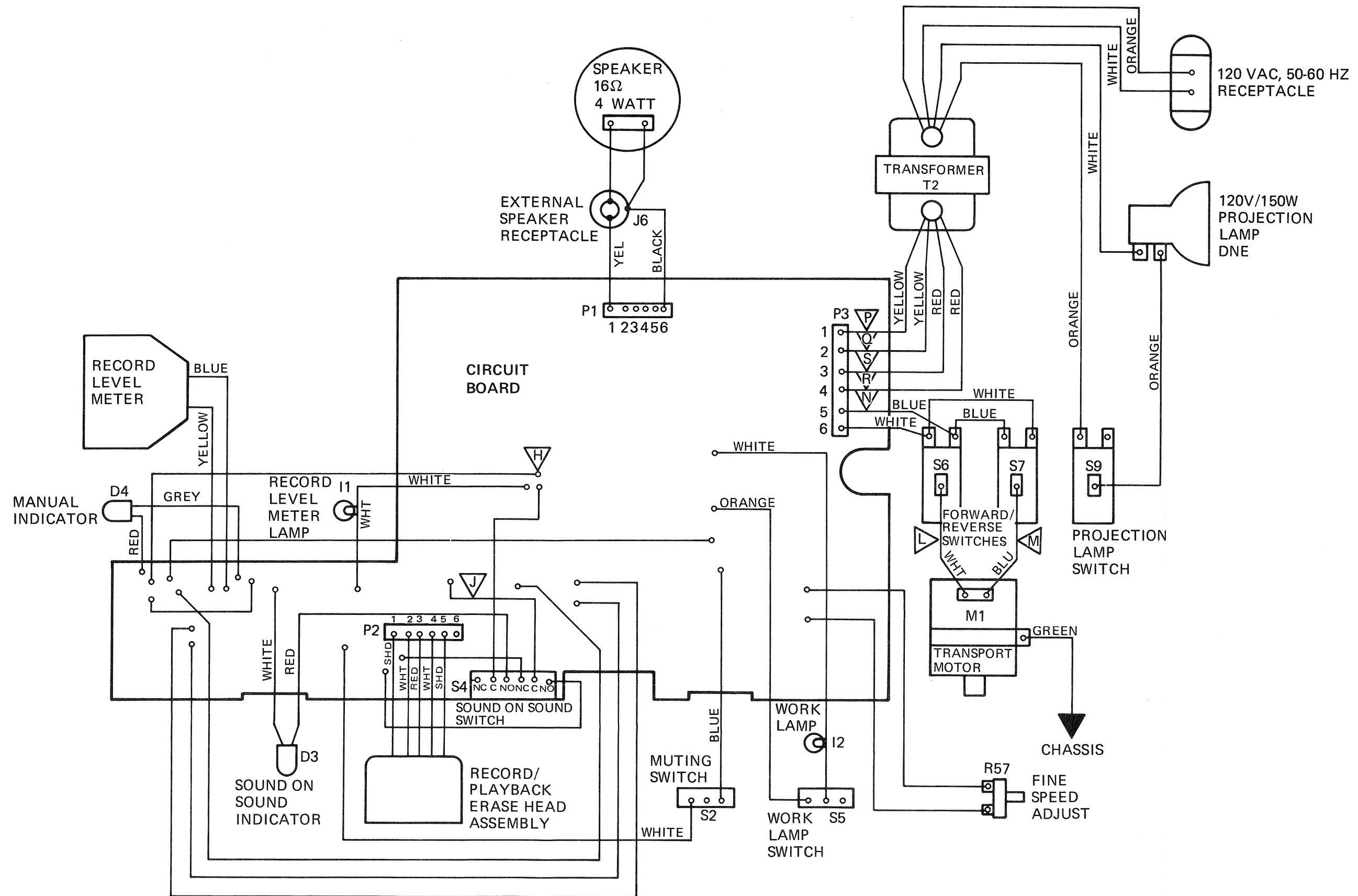

3100 S Schematic

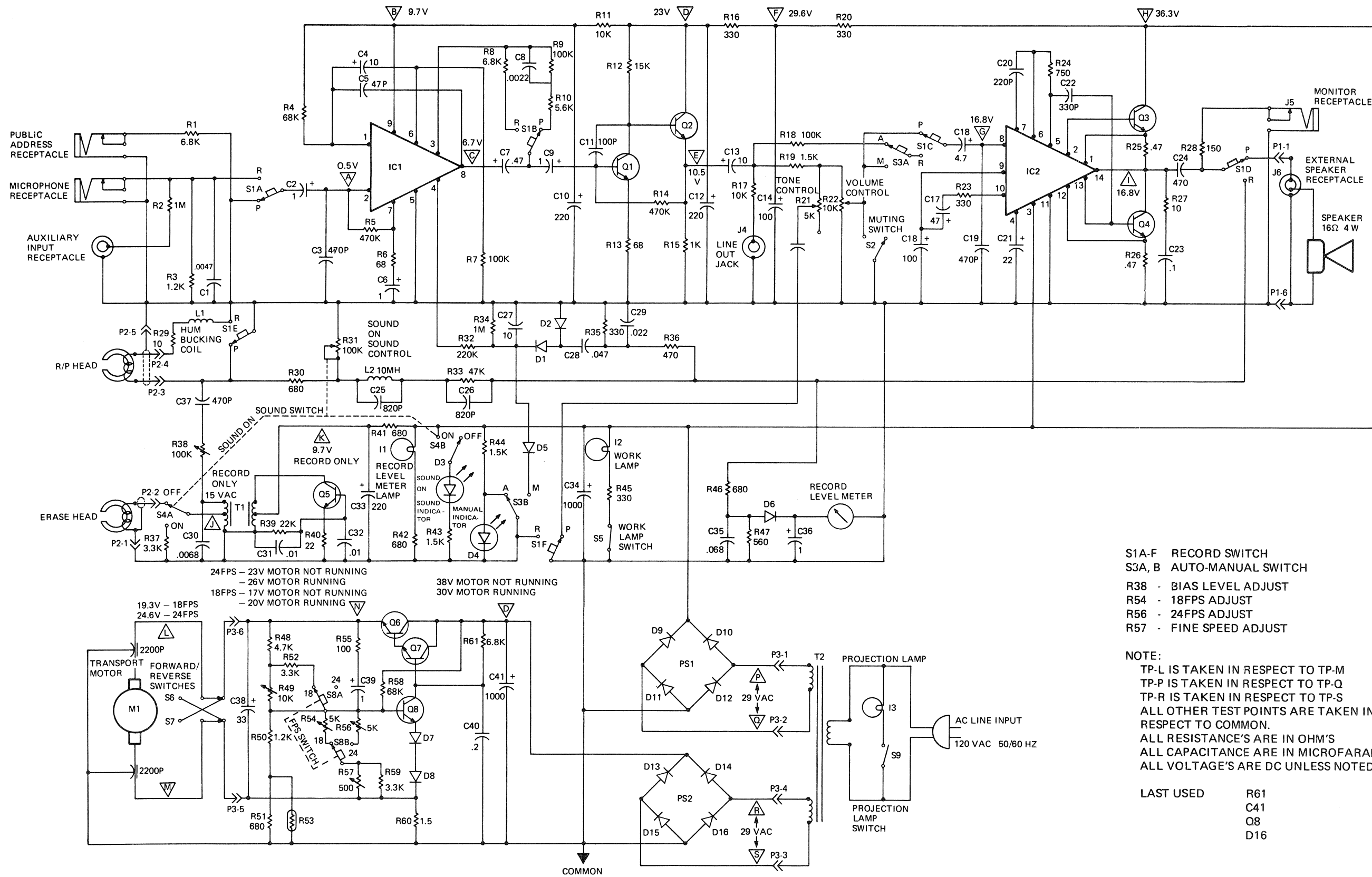

- S1A-F RECORD SWITCH
- S3A, B AUTO-MANUAL SWITCH
- R38 - BIAS LEVEL ADJUST
- R54 - 18FPS ADJUST
- R56 - 24FPS ADJUST
- R57 - FINE SPEED ADJUST

NOTE:
 TP-L IS TAKEN IN RESPECT TO TP-M
 TP-P IS TAKEN IN RESPECT TO TP-Q
 TP-R IS TAKEN IN RESPECT TO TP-S
 ALL OTHER TEST POINTS ARE TAKEN IN RESPECT TO COMMON.
 ALL RESISTANCE'S ARE IN OHM'S
 ALL CAPACITANCE ARE IN MICROFARAD'S
 ALL VOLTAGE'S ARE DC UNLESS NOTED

LAST USED	R61
	C41
	Q8
	D16

3100 S Block Diagram

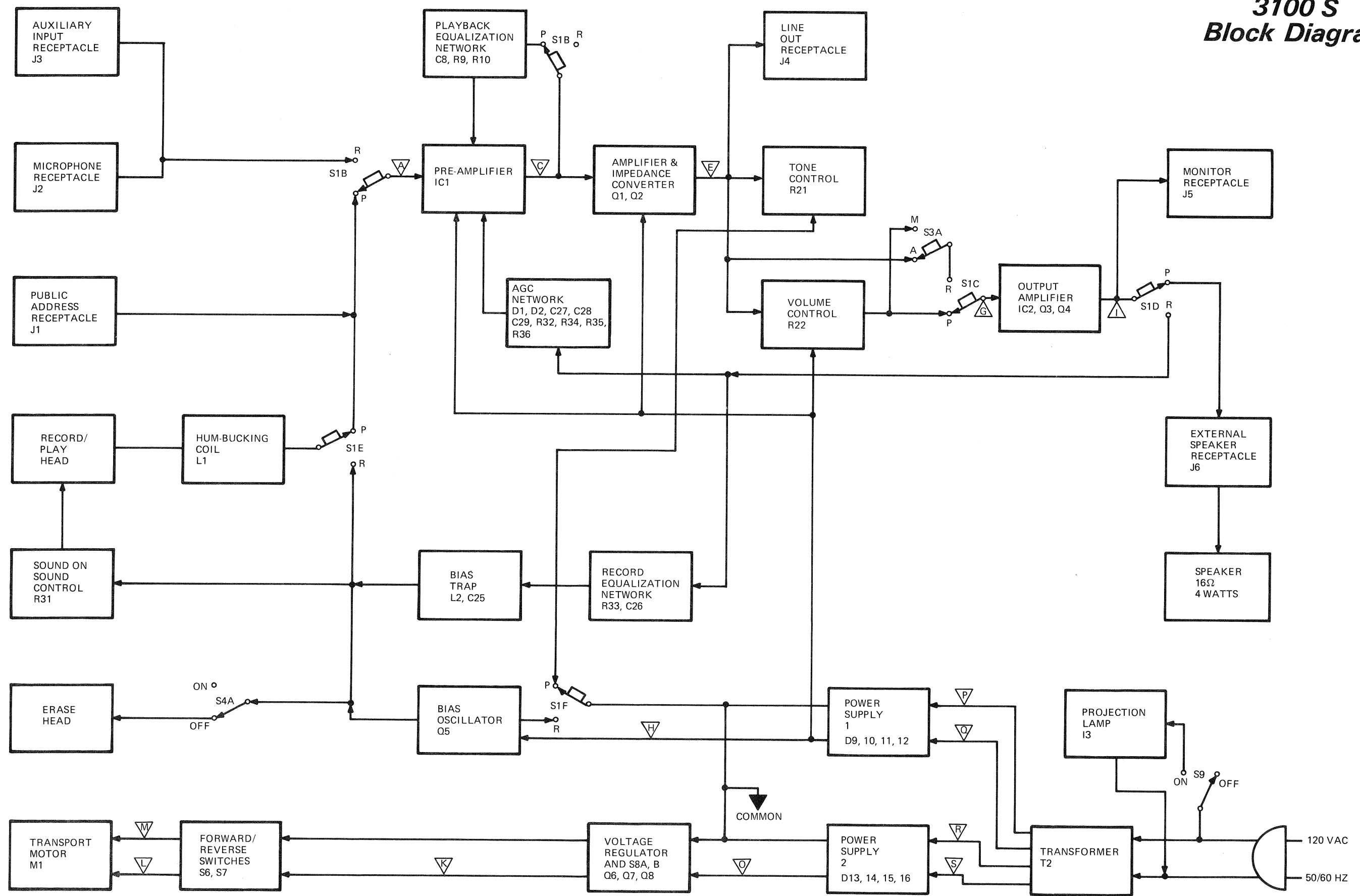

**3100 S
Circuit Board
Component Side**

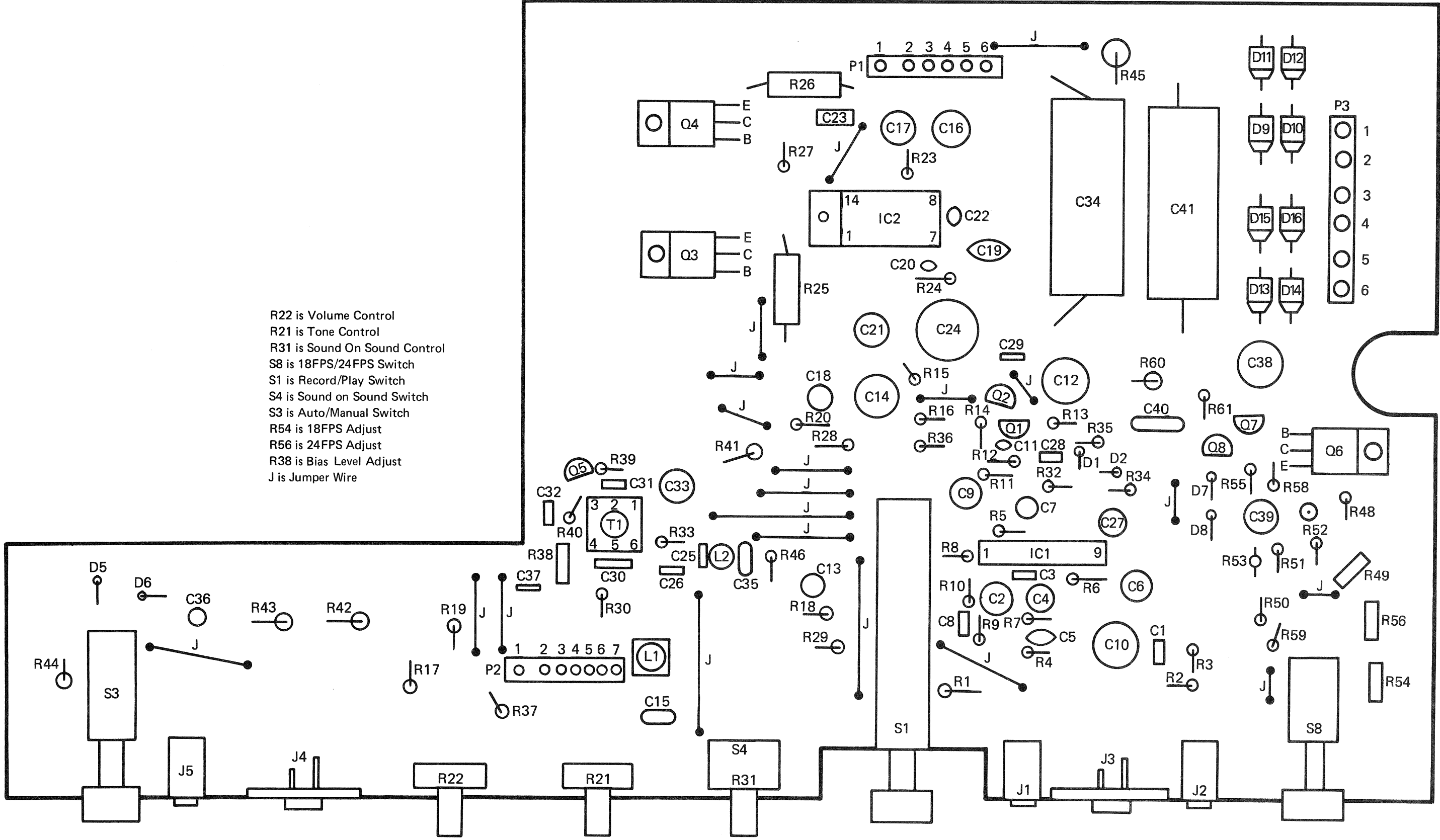

R22 is Volume Control
 R21 is Tone Control
 R31 is Sound On Sound Control
 S8 is 18FPS/24FPS Switch
 S1 is Record/Play Switch
 S4 is Sound on Sound Switch
 S3 is Auto/Manual Switch
 R54 is 18FPS Adjust
 R56 is 24FPS Adjust
 R38 is Bias Level Adjust
 J is Jumper Wire



2000S, 3000S
& 3100S

Supplement No.4

Date: 4/30/77

SUPPLEMENT TO SERVICE MANUAL 125-881

3100S ONLY

MUTING SWITCH

It has been brought to our attention that the muting switch in the GAF 3100S Sound Projector may go out of adjustment. When this occurs, there will be no sound produced in the forward mode.

FUNCTION

The muting switch is designed to short the input to the power amplifier IC-2 (Pin 8) to ground, when the main switch is in the reverse mode. The switch is actuated by the small cam control, (Item 70, page 3 of 3000S Illustrated Parts Manual).

LOCATION

The muting switch is located directly above the room light switch and are both activated by the same cam mentioned above.

ADJUSTMENT

The muting switch should be adjusted to close in the project mode. In the reverse mode, it should be adjusted to remain open preventing sound playback. If the switch is not adjusted properly, it may cause intermittent or no sound in the project mode.

ILLUSTRATED PARTS MANUAL
for
SUPER 8MM SOUND
MOVIE PROJECTORS



GAF CORPORATION
Photo & Repro Group
Portland, Oregon

PART NO. 881-950-02

HOW TO USE THE ILLUSTRATED PARTS MANUAL

USING THE PARTS LIST

This parts manual includes all variable and common parts. Indented numbers in the parts list heading are used to indicate assemblies and component parts of assemblies. Number 1 is the major assembly. Part descriptions which are indicated under 2, 3 and 4 are components of the major assembly shown above.

If the part description has a symbol (a)* be sure to read the footnote which will have important information affecting the specific part.

PRICE LIST

The service parts price list is a separate book which contains prices of service parts for all parts Manuals. This price list is in numerical order by part number. The correct list price can be obtained by first finding the part number in any of the parts manuals and then locating the same number in the price list.

SUPPLEMENTS AND REVISIONS

Supplementary pages may be added to this manual at later dates and must be filed in the proper location by page number, revision number and date. Changes on these pages will be noted by use of "R" and the revision number (EXAMPLE: R3).

CODE NUMBER IDENTIFICATION

A 3/8" diameter white sticker in all projectors identifies each projector by a code number representing the week of manufacture (refer to Manufacturing Calendar.) The code number may also be used to determine warranty periods. Sticker locations:

- (1) 2 x 2 projectors—inside projector under the access cover.
- (2) 8MM projectors—on film path assembly under movement housing.
- (3) 447 series 2 x 2 projectors—inside cord storage compartment at the top.

ORDERING PARTS

To order repair parts use the item numbers on the exploded views to locate the part in the parts list. Always order by part number and name, and order carefully in order to get the correct part for the model you are working on, assuring a match of color, parts and trim. (Please include projector code number for unit identification when ordering parts.) Order replacement parts from Consumer Photo Division, GAF Corporation, P.O. Box 490, Portland, Oregon 97207. All parts shipped f.o.b. Portland, Oregon.

INDEX

CONTROL PANEL, CIRCUIT BOARD AND OPTICAL SYSTEM	1
RECORDING HEAD, FLYWHEEL AND ASSOCIATED PARTS	2
LENS MOUNT, APERTURE, SHUTTER AND SWITCH CONTROL SYSTEMS.....	3
MAIN DRIVE AND BLOWER SYSTEM	5
AMPLIFIER ASSEMBLY (MODELS 2000S AND SEARS)	7
AMPLIFIER ASSEMBLY (MODEL 3000S)	9
FRONT AND REAR HOUSINGS AND ACCESSORIES.....	11
WIRING DIAGRAM.....	12

©GAF CORPORATION 1976

® T.M. Reg. U.S. Pat. Off.
GAF Corporation, New York, N.Y.
Marque Deposee; Marca Registrada
Printed in U.S.A.



GAF CORPORATION
Photo & Repro Group
Portland, Oregon

CONTROL PANEL, CIRCUIT BOARD AND OPTICAL SYSTEM

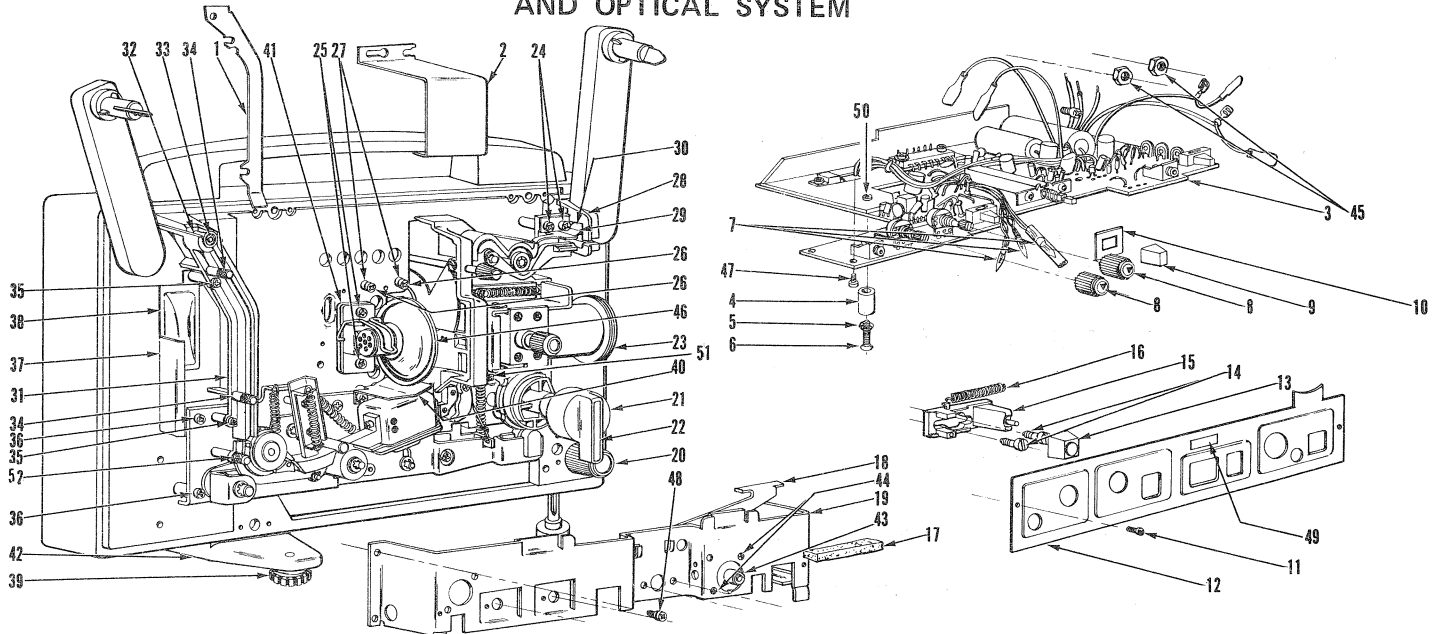

Item	Part No.	Description				
		1	2	3	4	
1	881-846	Cover—Rear Guide, Upper				
2	881-831	Shield—Heat, Lamp				
3		Amplifier/Playback (See Page 8-A)				
4	881-621	Spacer				
5	881-622	Spacer				
6	505-037	Screw—3.0 x 30.0MM				
7	881-551	Lamp Assembly				
8	{ 881-815 881-011	Knob—Control Plate—Volume Control				
9	881-823	Knob—Speed Change				
10	881-824	Plate—Knob				
11	505-020	Screw—2.6 x 6.0MM				
12	{ 881-814 881-800 881-833	Nameplate—Control Panel (2000S) Nameplate—Cont. Panel (2000S) 18-24FPS Nameplate—Cont. Panel (2000S) 18-24FPS, Speed Control				
	{ 881-818 881-700 881-059	Nameplate—Control Panel (3000S) Nameplate—Cont. Panel (Sears) Nameplate—Cont. Panel (3000S) W/Speed Control				
	{ 881-821 881-009 881-896	Knob—Record Insert—Cancel Knob Spring—Knob				
	14	505-048	Screw—2.6 x 4.0MM			
	{ 881-822 881-010 881-715	Knob—Record Lock Button—Rec., Cancel Pin—Spring				
16	881-649	Spring—Record Lock				
17	881-650	Shield—Light				
18	{ 881-651 881-006 881-008 881-030 881-004	Lever—Erase Spring—Rec., Cancel Lever Pushnut Pin Pushnut				
	19	881-830	Panel—Control			
	20	{ 881-506 881-007	Knob & Shaft—Elev. Foot Lock Insert—Knob, Elevating			
		881-826	Knob—Control			
22	881-827	Plate—Trim, Knob				

Item	Part No.	Description				
		1	2	3	4	
23	{ 881-521 881-867 881-578 881-699	Lens—Projection, Zoom Nameplate—Lens Lens—Projection, Zoom (Sears) Nameplate—Lens (Sears)				
	24	505-038	Screw—3.0 x 30.0MM			
	25	505-031	Screw—3.0 x 10.0MM			
	26	505-011	Screw—2.5 x 5.0MM			
27	881-620	Spacer				
28	881-847	Guide—Film Feed				
29	881-848	Bracket—Film Feed				
30	881-849	Roller—Film Feed				
31	881-530	Film Guide Assy.—Upper				
32	881-653	Roller—Film Guide				
33	881-634	Grip Ring				
34	881-652	Thumbscrew—Film Guide				
35	{ 505-036 505-035	Screw—3.0 x 25.0MM Screw—3.0 x 15MM				
	36	505-040	Screw—4.0 x 8.0MM			
37	881-840	Shadeplate				
38	881-838	Shield—Drive Pulley				
39	{ 881-508 881-002	Foot—Rear, Adjustable Rubber—Rear Leg				
	40	881-837	Shield—Heat, Sound Head			
41	{ 881-801 881-000 881-757 881-001	Plate—Socket, Lamp Lamp Socket Plate—Lamp Socket Clamp—Socket				
	42	{ 881-507 505-064	Foot—Rear, Stationary Screw—4 x 12MM			
		43	881-807	Receptacle—Aux. Input		
	44	505-007	Screw—2.6 x 6.0MM			
45	881-623	Nut—Hex				
46	575-056	Lamp—Projection, DNE				
47	505-017	Screw—2.5MM x 6MM				
48	505-025	Screw—3.0 x 6.0MM				
49	881-687	Window—Red				
50	881-003	M-3—Boss				
51	505-014	Screw—2.5 x 6MM				
52	881-707	Thumbscrew—Film Guide				

RECORDING HEAD, FLYWHEEL AND ASSOCIATED PARTS

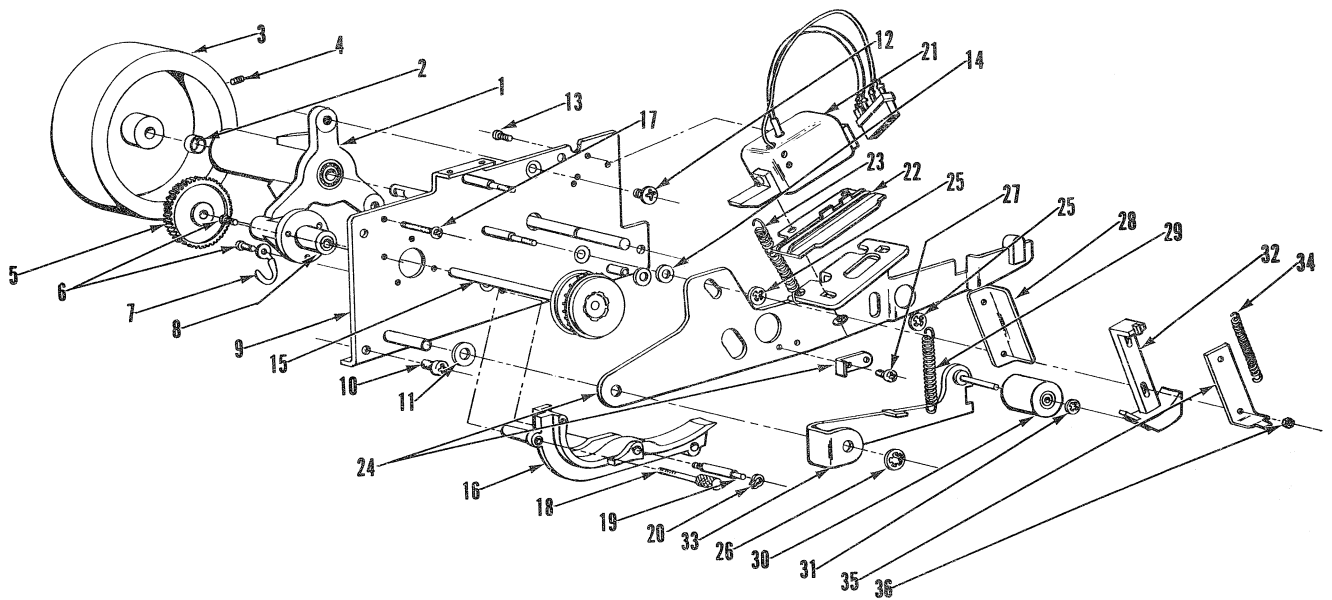

Item	Part No.	Description			
		1	2	3	4
1	881-853	Bearing & Shaft Housing Assy.			
	881-688	Bearing—Ball			
	881-012	Capstan			
	881-033	Grip Ring			
2	881-858	Collar—Flywheel Bearing			
3	881-857	Flywheel			
4	505-046	Setscrew—4.0 x 5.0MM			
5	881-879	Gear—Rear Sprocket			
	505-062	Screw			
6	505-026	Screw—3.0 x 6.0MM			
7	881-637	Washer—Tiedown, Insulated			
8	881-538	Bearing—Rear Sprocket			
9	881-522	Plate—Pivot			
10	505-040	Screw—4.0 x 8.0MM			
11	881-611	Washer			
12	505-041	Screw—4.0 x 8.0MM			
13	505-013	Screw—2.5 x 4.0MM			
14	881-613	Washer			
15	881-537	Sprocket & Shaft Assy.			
	881-013	Washer			
16	881-531	Guide—Film, Lower			
17	505-035	Screw—3.0 x 15.0MM			
18	881-707	Thumbscrew—Film Guide			
19	881-864	Stud—Film Guide			
20	881-634	Grip Ring			
21	881-502	Head Assy.—Playback (2000S, Sears)			
	881-543	Head Assy.—Record/Playback (3000S)			
	881-571	Recording Head			
	881-572	Eraser Head (3000S) (Old)			
	881-052	Eraser Head (3000S) (New)			
	881-573	Connector—6 Prong			

Item	Part No.	Description			
		1	2	3	4
21	505-019	Screw—2.5 x 10MM			
	881-015	Cover—Head			
	881-016	Mask—Head			
	881-017	Plate—Head			
	505-013	Screw—2.5 x 4MM			
	505-003	Screw—2.0 x 3MM			
	505-047	Screw—2.0 x 10.5MM			
	505-052	Screw—2.0 x 8.8MM			
22	881-014	Spring—Sound Pressure Plate			
	881-524	Head Skate Assy, Sound			
	505-061	Screw			
23	881-034	Pat			
	881-607	Spring—Roller Arm			
24	881-523	Arm—Pressure Plate			
25	881-629	Pushnut			
26	881-628	Pushnut			
27	505-055	Screw—3.0 x 5.0MM			
	881-614	Washer			
28	881-866	Plate—Rear			
29	881-606	Spring—Pressure Arm			
30	881-526	Roller—Pressure Arm			
31	881-631	Pushnut			
32	881-708	Guide—Pressure			
33	881-525	Arm—Pressure Roller			
34	881-603	Spring—Pressure Guide			
35	881-865	Plate—Front			
36	881-627	Nut—Hex			

LENS MOUNT, APERTURE, SHUTTER AND SWITCH CONTROL SYSTEMS

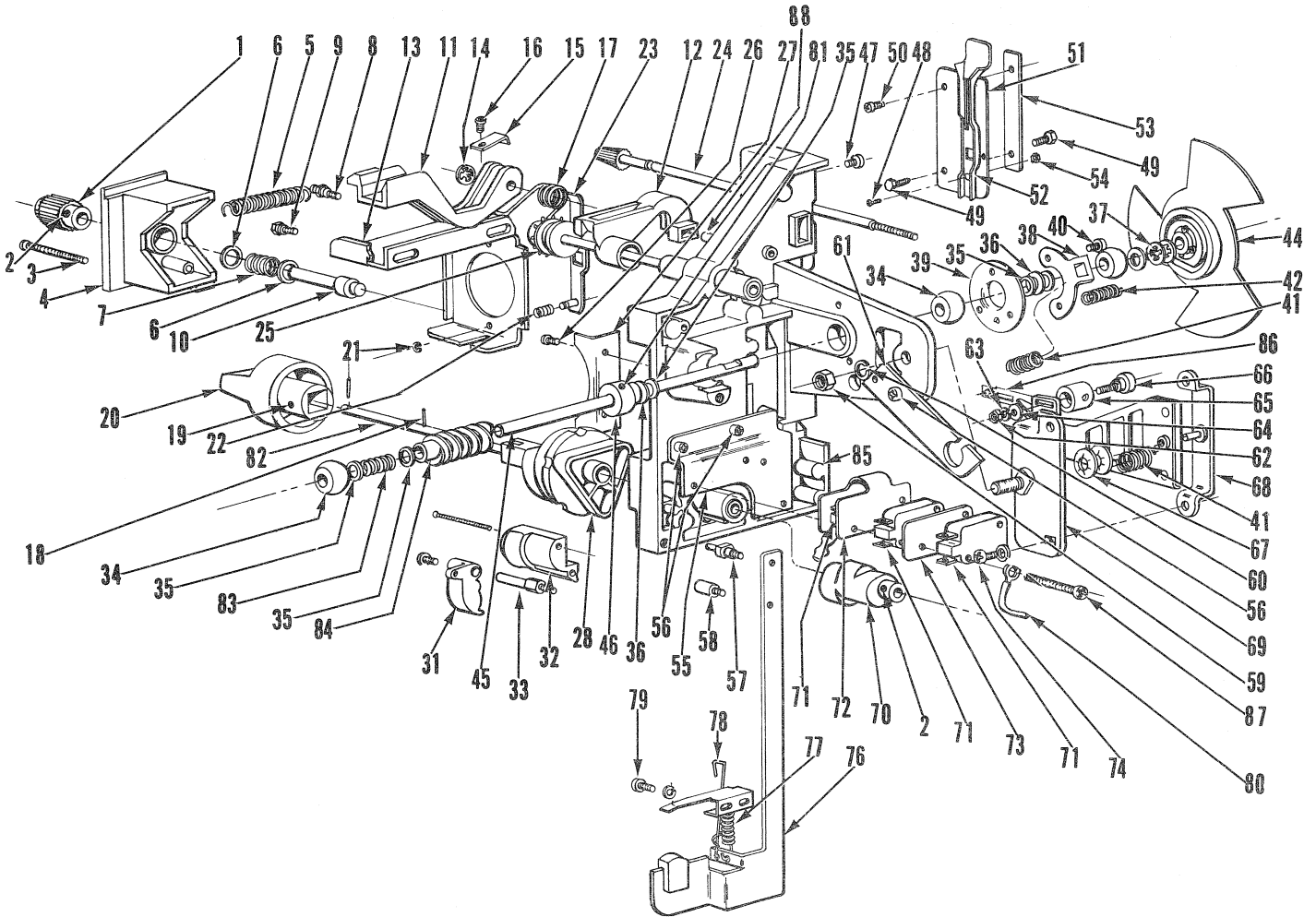

LENS MOUNT, APERTURE, SHUTTER AND SWITCH CONTROL SYSTEMS

Item	Part No.	Description				Item	Part No.	Description				
		1	2	3	4			1	2	3	4	
1	{ 881-869	Knob—Focus, Small (Old)				36	881-663	Washer—Shutter Shaft, Large				
	{ 881-049	Knob—Focus, Large (New)				37	881-628	Pushnut				
	{ 881-051	Plate, Knob				38	881-664	Retainer—Spring				
	{ 881-018	Insert—Focusing				39	881-686	Retainer—Bearing				
	{ 881-051	Trimplate—Large				40	505-026	Screw—3.0 x 6.0MM				
2	505-044	Setscrew—3.0 x 4.0MM				41	881-666	Spring—Shutter Shaft				
3	505-018	Screw—2.5 x 30.0MM				42	881-667	Spring—Film Claw, Small				
4	881-868	Bracket—Lens				44	{ 881-532	Shutter Assy.				
5	881-605	Spring—Lens Bracket					{ 505-009	Screw—2.0 x 7.0MM				
6	881-662	Washer				45	881-669	Shaft—Shutter				
7	881-871	Spring—Focus Shaft				46	881-670	Collar—Shaft				
8	881-656	Stud Screw—Hex				47	505-050	Screw—4.0 x 4.5				
9	881-657	Shoulder Screw—Hex				48	505-004	Screw—2.0 x 3.5				
10	881-670	Shaft—Focus Knob				49	505-008	Screw—2.0 x 6.0				
11	{ 881-851	Guide—Front, Lower				50	505-005	Screw—2.0 x 4.0				
	{ 881-036	Film Stopper—Threader				51	881-844	Plate—Mounting				
	{ 881-037	Pin—Threader				52	881-843	Plate—Aperture				
12	{ 881-850	Guide—Front, Upper (Old)				53	881-845	Spacer				
	{ 881-041	Guide—Front, Upper (New)				54	881-627	Nut—Hex				
13	881-841	Bracket—Pressure Plate				55	881-834	Bracket—Switch				
14	881-630	Pushnut				56	505-026	Screw—3.0 x 6.0MM				
15	881-658	Plate—Spring				57	881-891	Shaft				
16	505-023	Screw—3.0 x 3.0				58	{ 881-899	Guide—Actuator Arm (Old)				
17	{ 881-852	Spring—Front Guide (Old)					{ 881-043	Guide—Actuator Arm (New)				
	{ 881-042	Spring—Front Guide (New)				59	881-624	Nut—Hex				
18	881-636	Roll Pin				60	881-616	Lockwasher				
19	505-062	Setscrew—3.0 x 4.0MM				61	881-886	Retainer—Wire				
20	881-826	Knob—Control				62	881-626	Nut—Hex				
21	881-635	E-Ring				63	881-619	Lockwasher				
22	{ 881-054	Spring, Lower, Pressure Plate				64	881-614	Washer				
	{ 881-665	Spring, Upper, Pressure Plate				65	881-862	Bushing—Framer				
	{ 881-022	Washer				66	881-863	Screw—Framer				
23	{ 881-842	Plate—Pressure (Old)				67	881-671	Pushnut				
	{ 881-053	Plate—Pressure (New)				68	881-672	Bracket—Claw Retainer				
	{ 881-021	Pin—Skate				69	881-673	Bracket—Framer				
24	{ 881-535	Shaft Assy.—Framer				70	881-529	Cam—Control, Small				
	{ 881-660	Knob—Framer Shaft				71	881-808	Switch—Miniature				
25	881-536	Sprocket & Shaft Assy.				72	881-836	Insulator				
26	505-028	Screw—3.0 x 6.0				73	881-835	Insulation—Phenolic				
27	881-839	Bracket—Lamp				74	505-027	Screw—3.0 x 6.0MM				
28	{ 881-828	Cam—Control, Large (Old)				76	881-527	Arm—Actuator				
	{ 881-055	Cam—Control, Large (New)				77	881-602	Spring—Actuator Arm				
31	{ 881-855	Guide—Moveable (Old)				78	{ 881-691	Spring—Loop Guide Tension (Old)				
	{ 881-044	Guide—Moveable (New)					{ 881-047	Spring, Loop Guide Tension (Looper Spring) (New)				
32	{ 881-854	Guide—Fixed (Old)				79	505-014	Screw—2.5 x 6.0				
	{ 881-045	Guide—Fixed (New)				80	881-637	Washer—Tiedown, Insulated				
	{ 881-038	Shaft "B"—Looper				81	505-046	Setscrew—4.0 x 5.0MM				
	{ 881-039	E-Ring				82	881-528	Shaft—Control				
	{ 881-040	Pin—Looper				83	881-711	Spring—Shutter Shaft				
33	{ 881-856	Shaft—Guide (Old)				84	881-712	Worm—Shutter Shaft				
	{ 881-046	Shaft—Guide (New)				85	881-023	Rotary Click, Spring				
34	881-661	Bearing				86	881-689	Claw Arm				
35	881-662	Washer				87	505-039	Screw 3 x 40MM				
						88	881-019	Shaft, Self-Threading				

MAIN DRIVE AND BLOWER SYSTEM

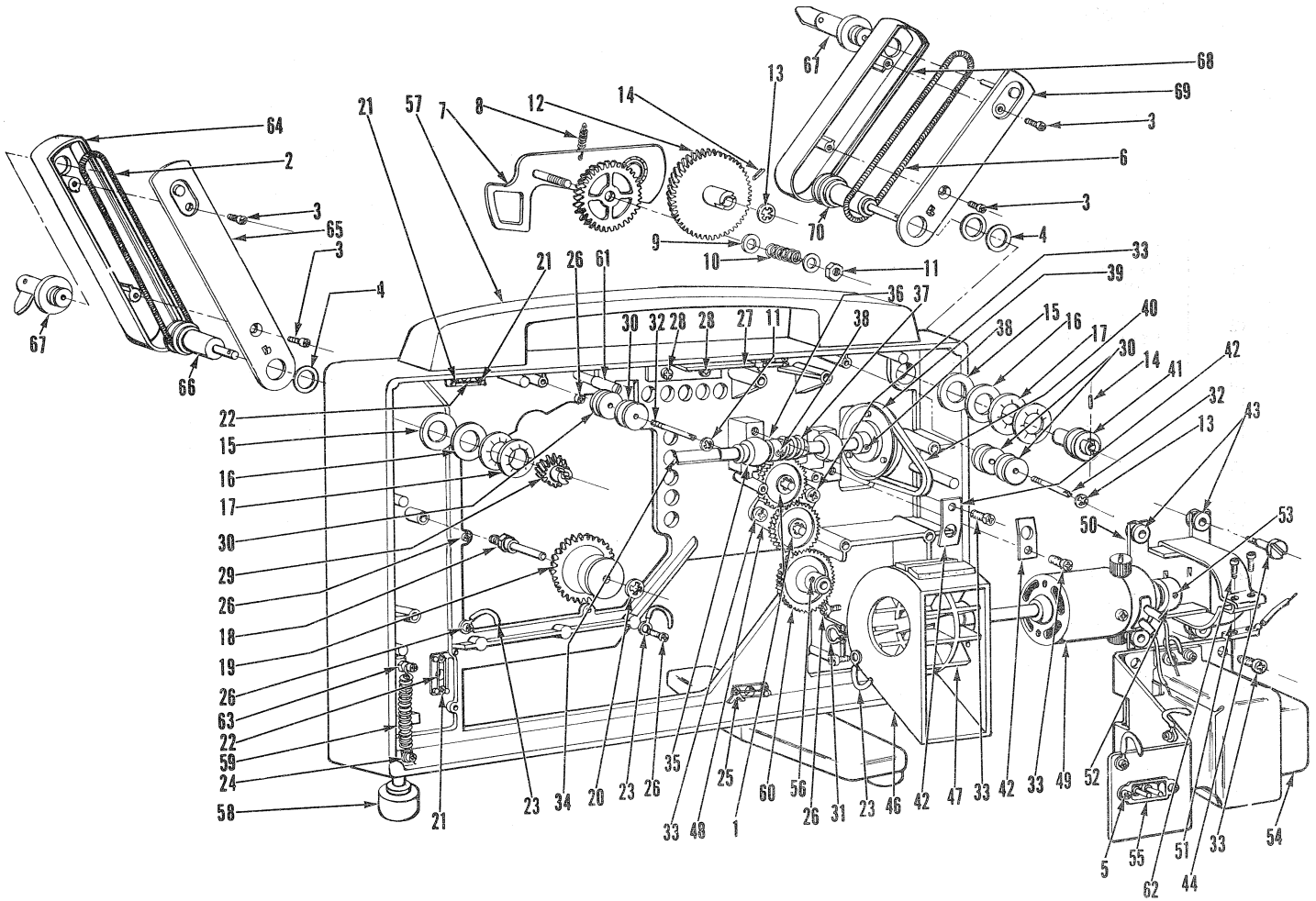

MAIN DRIVE AND BLOWER SYSTEM

Item	Part No.	1 2 3 4	Description	Item	Part No.	1 2 3 4	Description
1	881-630		Pushnut	40	881-881		Belt—Main Drive, Rubber
2	{ 881-883 881-056		Belt—Rewind (Old) Belt—Rewind (New)	41	881-709		Pulley—Takeup Arm
3	505-021		Screw—2.6 x 6.0MM	42	881-897		Retainer—Bearing
4	881-875		Washer	43	881-898		Grommet—Rubber
5	505-026		Screw—3 x 6MM	44	505-049		Screw—3.0 x 15.0MM
6	{ 881-884 881-703		Belt—Takeup Belt—Takeup—600 ft.	46	881-860		Housing—Blower
7	{ 881-539 881-026		Arm Assy.—Selector Gear—Fwd. Rev.	47	881-859		Blower Wheel
8	881-609		Spring—Selector Arm	48	{ 881-540 881-683		Plate Assy.—Idler Gear—Idler Plate
9	881-675		Washer	49	881-509		Motor Assy.—Drive
10	881-676		Spring—Selector Arm	50	881-643		Plate—Motor Mounting
11	881-677		Nut—Hex	52	881-642		Pulley—Motor
12	881-878		Gear	53	505-046		Setscrew—4.0 x 5.0MM
13	881-027		Washer	54	{ 881-510 881-029 881-028		Transformer—Power Plate "C"—AC Plate—Lag
14	881-713		Roll Pin	55	881-805		Receptacle—Line Cord
15	881-874		Washer	56	505-062		Setscrew—3.0 x 4.0MM
16	881-873		Washer		{ 881-504 881-580		Handle—Carrying Nut—Hex
17	881-872		Pushnut	57	{ 881-025 505-063 881-580 881-024		Plate—Lag Screw Nut Washer
18	881-880		Shaft—Drive Gear	58	881-505		Foot—Elevating-Front
19	881-877		Gear—Drive	59	881-604		Spring—Elevating Foot
20	881-648		E—Ring	60	881-879		Gear
21	505-012		Screw—2.5 x 4.0MM	61	881-714		Stud Screw
22	{ 881-610 881-035		Spring—Lock Terminal	62	505-034		Screw—3.0 x 12.0MM
23	881-637		Washer—Tiedown, Insulated	63	{ 881-626 505-033		Nut—Hex Screw—3.0 x 10MM
24	505-027		Screw—3.0 x 6MM	64	{ 881-511 881-518		Arm Assy.—Supply (Small) Arm Assy.—Supply (Large)
25	881-678		Washer—Spring Lock	65	881-512		Cover—Supply Arm
26	505-033		Screw—3.0 x 10.0MM	66	{ 881-513 881-582		Pulley—Supply Arm (Small) Pulley—Supply Arm (Large)
27	881-832		Bracket	67	{ 881-514 881-583		Spindle—Supply Arm (Small) Spindle—Supply Arm (Large)
28	505-025		Screw—3.0 x 6.0MM	68	{ 881-515 881-701		Arm Assy.—Takeup Arm Assy.—Takeup (600 ft.)
29	881-888		Gear—Rewind	69	{ 881-516 881-702		Cover—Takeup Arm Cover—Takeup Arm (600 ft.)
30	881-885		Pulley—Guide	70	{ 881-517 881-584		Pulley—Takeup Arm (Small) Pulley—Takeup Arm (Large)
31	881-633		Grip Ring		881-882		Belt—Main Drive, Steel (Not Illus.)
32	{ 881-679 881-631		Shaft—Guide Pulley Pushnut				
33	505-040		Screw—4.0 x 8.0MM				
34	881-861		Key—Drive				
35	881-661		Bearing				
36	881-670		Collar—Shaft				
37	881-680		Worm—Drive Shaft				
38	505-046		Setscrew—4.0 x 5.0MM				
39	881-519		Pulley—Main Drive				

AMPLIFIER ASSEMBLIES (MODELS 2000S AND SEARS)

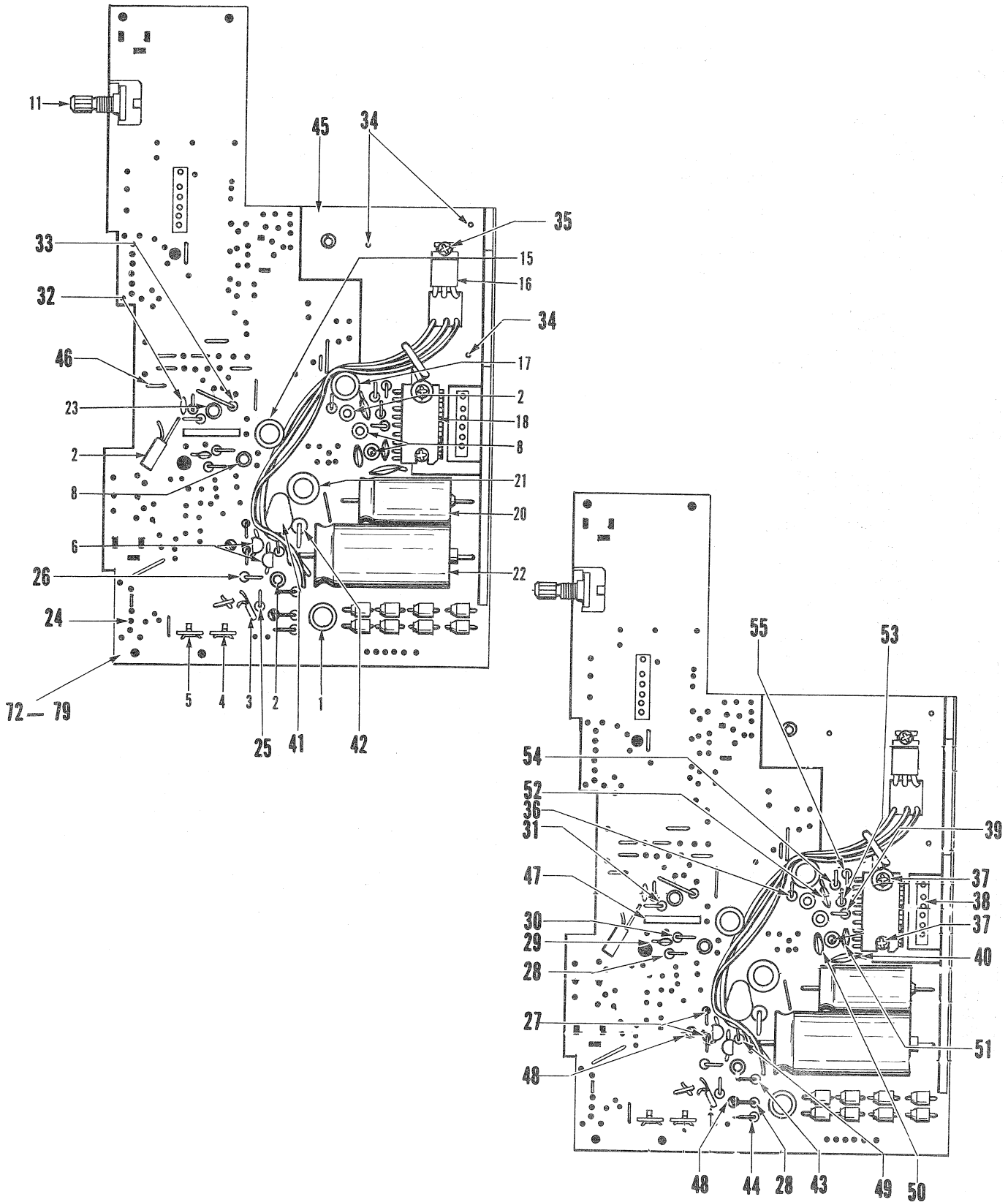

**AMPLIFIER ASSEMBLIES
(MODELS 2000S AND SEARS)**

Item	Part No.	Description				Item	Part No.	Description			
		1	2	3	4			1	2	3	4
	881-501	Amplifier—Playback				36	881-725	Resistor—1/4W 2.2K Ω			
	881-579	Amplifier—Playback (18-24 fps)				37	505-030	Screw			
1	881-552	Capacitor—33 μ F 50V				38	881-573	Connector—6 Prong			
2	881-553	Capacitor—1 μ F 50V				39	881-726	Resistor—1/4W 220 Ω			
3	881-554	Thermistor—C-125				40	881-727	Capacitor—0.3 μ F (12V)			
4	881-555	Pot—10 K Ω				41	881-728	Capacitor—0.22 μ F (50V)			
5	881-556	Pot—2 K Ω				42	881-729	Resistor—2W 1.5 Ω			
6	881-681	Transistor—C823A-R4E				43	881-730	Resistor—1/4W 100 Ω			
8	881-558	Capacitor—10 μ F 16V				44	881-731	Resistor—1/4W 4.7K Ω			
11	881-560	Control Pot—Volume 10 K Ω				45	881-732	Radiation Plate			
15	881-563	Capacitor—220 μ F 16V				46	881-733	Capacitor—0.001 μ F (50V)			
16	881-645	Transistor—D313E-9C				47	881-734	I.C. BA313			
17	881-564	Capacitor—100 μ F 16V				48	881-735	Test Point			
18	881-565	I.C.—AN2488				49	881-736	Resistor—1/4W 6.8K Ω			
20	881-567	Capacitor—1000 μ F 25V				50	881-737	Capacitor—0.1 μ F (12V)			
21	881-568	Capacitor—470 μ F 16V				51	881-738	Capacitor—1000 pF (50V)			
22	881-569	Capacitor—1000 μ F 50V				52	881-739	Capacitor—470 pF (50V)			
23	881-570	Capacitor—0.47 μ F 16V				53	881-740	Resistor—1/4W 33K Ω			
24	881-704	Switch—Slide (18-24 fps)				54	881-741	Resistor—1/4W 22K Ω			
25	881-716	Resistor—1/4W 680 Ω				55	881-742	Resistor—1/4W 10K Ω			
26	881-717	Resistor—1/4W 1.2K Ω				68	881-754	Diode—DS-130 YD			
27	881-718	Diode—IS2473				72	881-585	Resistor, Carbon, 1/4W 1 K Ω			
28	881-719	Resistor—1/4W 68K Ω				73	881-586	Resistor, Variable 500 K Ω			
29	881-720	Capacitor—47 pF (50V)				74	881-587	Knob, Control			
30	881-721	Resistor—1/4W 68 Ω				75	881-588	Plate, Knob			
31	881-722	Resistor—1/4W 470K Ω				76	881-589	Washer			
32	881-723	Capacitor—0.0047 μ F (50V)				77	881-590	Boss, Control Knob			
33	881-724	Resistor—1/4W 15K Ω				78	505-065	Screw 1.7 x 5.0MM			
34	505-016	Screw				79	881-627	Nut			
35	505-028	Screw									

AMPLIFIER ASSEMBLIES (MODEL 3000S)

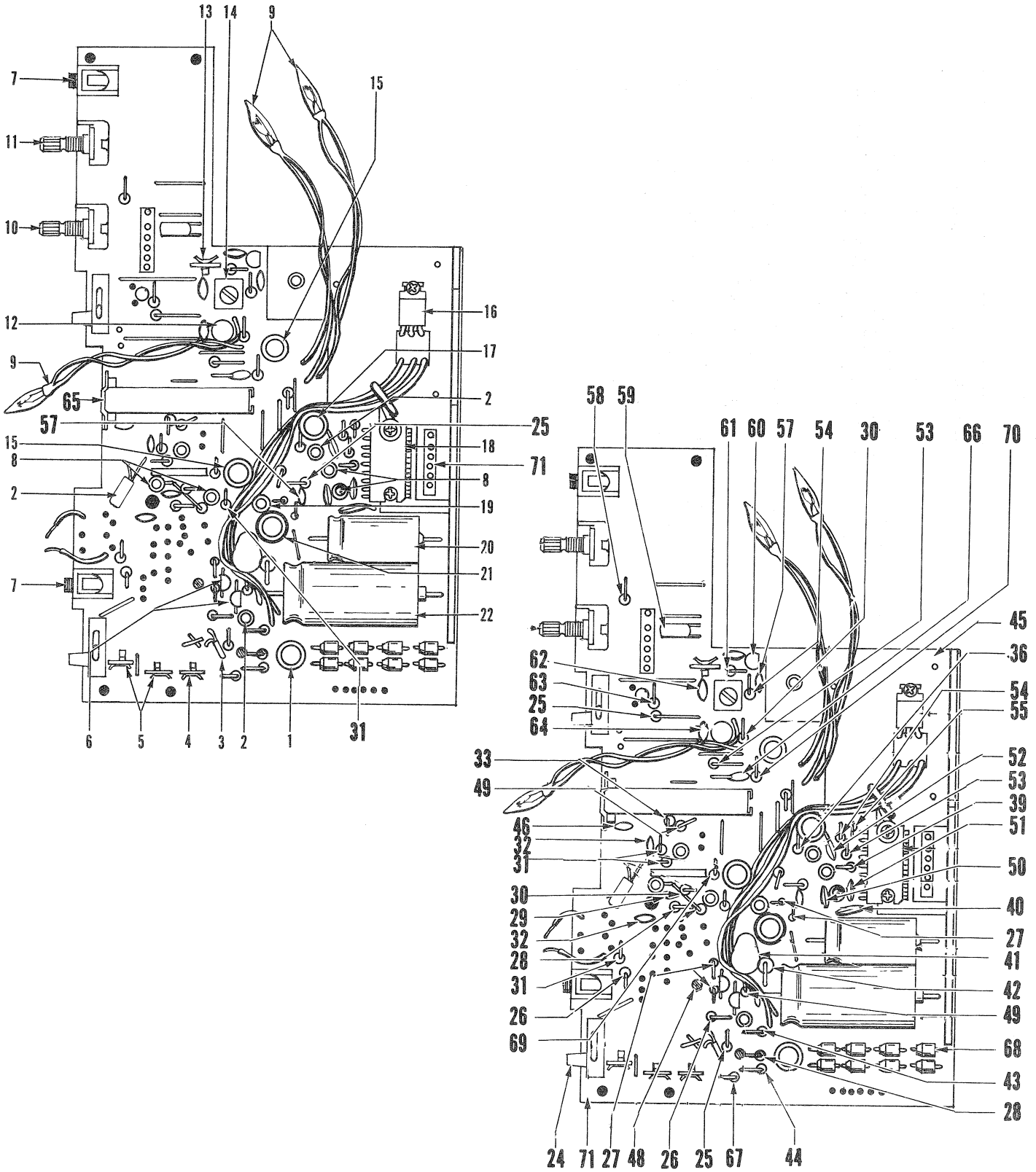

**AMPLIFIER ASSEMBLIES
(MODEL 3000S)**

Item	Part No.	Description				Item	Part No.	Description			
		1	2	3	4			1	2	3	4
	881-542	Amplifier—Record & Playback				36	881-725	Resistor—1/4W 2.2K Ω			
1	881-552	Capacitor—33 μ F 50V				37	505-030	Screw			
2	881-553	Capacitor—1 μ F 50V				38	881-573	Connector—6 Prong			
3	881-554	Thermistor—C-125				39	881-726	Resistor—1/4W 220 Ω			
4	881-555	Pot—10K Ω				40	881-727	Capacitor—0.3 μ F (12V)			
5	881-556	Pot—2K Ω				41	881-728	Capacitor—0.22 μ F (50V)			
6	881-681	Transistor—CB28A-R4E				42	881-729	Resistor—2W 1.5 Ω			
7	881-557	Jack—Ear Phone				43	881-730	Resistor—1/4W 100 Ω			
8	881-558	Capacitor—10 μ F 16V				44	881-731	Resistor—1/4W 4.7K Ω			
9	881-551	Lamp—Pilot				45	881-732	Radiation Plate			
10	881-559	Control Pot—Volume 100K Ω				46	881-733	Capacitor—0.001 μ F (50V)			
11	881-560	Control Pot—Volume 10K Ω				47	881-734	I.C. BA-313			
12	881-561	Coil—Induction				48	881-735	Test Point			
13	881-562	Pot—100K Ω				49	881-736	Resistor—1/4W 6.8K Ω			
14	881-646	Coil Oscillator				50	881-737	Capacitor—0.1 μ F (12V)			
15	881-563	Capacitor—220 μ F 16V				51	881-738	Capacitor—1000 pF (50V)			
16	881-645	Transistor—D313E-9C				52	881-739	Capacitor—470 pF (50V)			
17	881-564	Capacitor—100 μ F 16V				53	881-740	Resistor—1/4W 33K Ω			
18	881-565	I.C.—AN2488				54	881-741	Resistor—1/4W 22K Ω			
19	881-566	Capacitor—3.3 μ F 25V				55	881-742	Resistor—1/4W 10K Ω			
20	881-567	Capacitor—1000 μ F 25V				56	881-743	Resistor—1/4W 330 Ω			
21	881-568	Capacitor—470 μ F 16V				57	881-744	Capacitor—0.01 μ F (50V)			
22	881-569	Capacitor—1000 μ F 50V				58	881-745	Resistor—1/4W 1.2K Ω			
23	881-570	Capacitor—0.47 μ F 16V				59	881-746	Capacitor—470 pF (50V)			
24	881-704	Switch—Slide (18-24 fps)				60	881-747	Transistor—2SC-1317 (S)			
25	881-716	Resistor—1/4W 680 Ω				61	881-748	Resistor—1/2W 22 Ω			
26	881-717	Resistor—1/4W 1.2K Ω				62	881-749	Capacitor—0.0068 μ F (50V)			
27	881-718	Diode—IS2473				63	881-750	Resistor—1/4W 10 Ω			
28	881-719	Resistor—1/4W 68K Ω				64	881-751	Capacitor—820 pF (50V)			
29	881-720	Capacitor—47 pF (50V)				65	881-020	Switch			
30	881-721	Resistor—1/4W 68 Ω				66	881-752	Capacitor—0.0015 μ F (50V)			
31	881-722	Resistor—1/4W 470K Ω				67	881-753	Resistor—1/4W 3.3K Ω			
32	881-723	Capacitor—0.0047 μ F (50V)				68	881-754	Diode—DS-130 YD			
33	881-724	Resistor—1/4W 15K Ω				69	881-755	Resistor—1/4W 100K Ω			
34	505-016	Screw				70	881-756	Resistor—1/4W 150 Ω			
35	505-028	Screw				71	881-574	Connector—6 Prong			

NOTE:

See page 8 for variable speed control components;
Items 72 through 79.

FRONT & REAR HOUSINGS AND ACCESSORIES

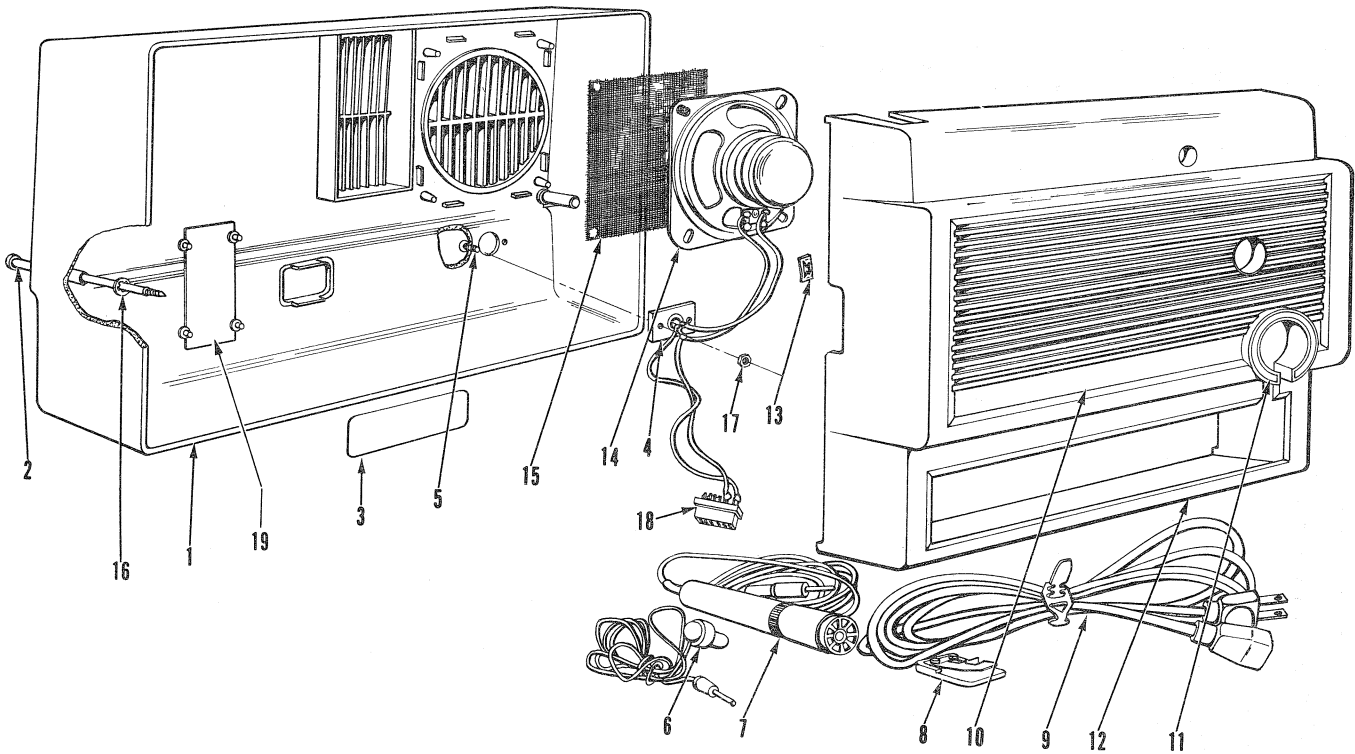

Item	Part No.	1 2 3 4	Description
1	881-503 881-577		Housing—Rear Housing—Rear (Sears)
2	881-684		Screw—Rear Housing
3	881-890 881-685 881-698 881-692 881-693		Plate—Specification (2000S) Plate—Specification (3000S) Plate—Specification (Sears) Plate—Specification, CSA (2000S) Plate—Specification, CSA (3000S)
4	881-806		Receptacle—Aux. Speaker
5	505-032		Screw—3.0 x 10.0MM
6	881-545		Earphone
7	881-544 881-825		Microphone Stand—Microphone
8	881-541		Trimmer—Film
9	881-809		Cord—Line
10	881-812 881-816 881-697		Nameplate—Front Housing (2000S) Nameplate—Front Housing (3000S) Nameplate—Front Housing (Sears)
11	881-813 881-817 881-696		Nameplate—Control Knob (2000S) Nameplate—Control Knob (3000S) Nameplate—Control Knob (Sears)
12	881-500 881-050 881-695 881-576 881-031 881-032		Housing—Front—Small Hole (Old) Housing—Front—Large Hole (New) Housing—Front (Canadian) Housing—Front (Sears) Ventilator Fastener—Cover Slide

Item	Part No.	1 2 3 4	Description
13	881-632		Pushnut
14	881-804		Speaker
15	881-893		Screen—Speaker
16	881-629		Pushnut
17	881-626		Nut—Hex
18	881-573		Connector—6 Prong
19	881-060 881-631		Plate Pushnut
	*881-900		Book—Instructions
	*881-909		Book—Instructions (Sears)**
	*881-901		Hang Tag
	*881-910		Hang Tag (Sears)
	*881-902		Carton—Projector (2000S)
	*881-903		Carton—Projector (3000S)
	*881-911		Carton—Projector (Sears)
	*881-907		Pad—Top
	*881-908		Pad—Bottom
	*881-705		400 Ft. Reel
	*881-706		600 Ft. Reel

*Not Illustrated, Packaging Material Only
 **Effective 1/1/76, 881-913 Sears Instruction Book

WIRING DIAGRAM

2000S
SEARS

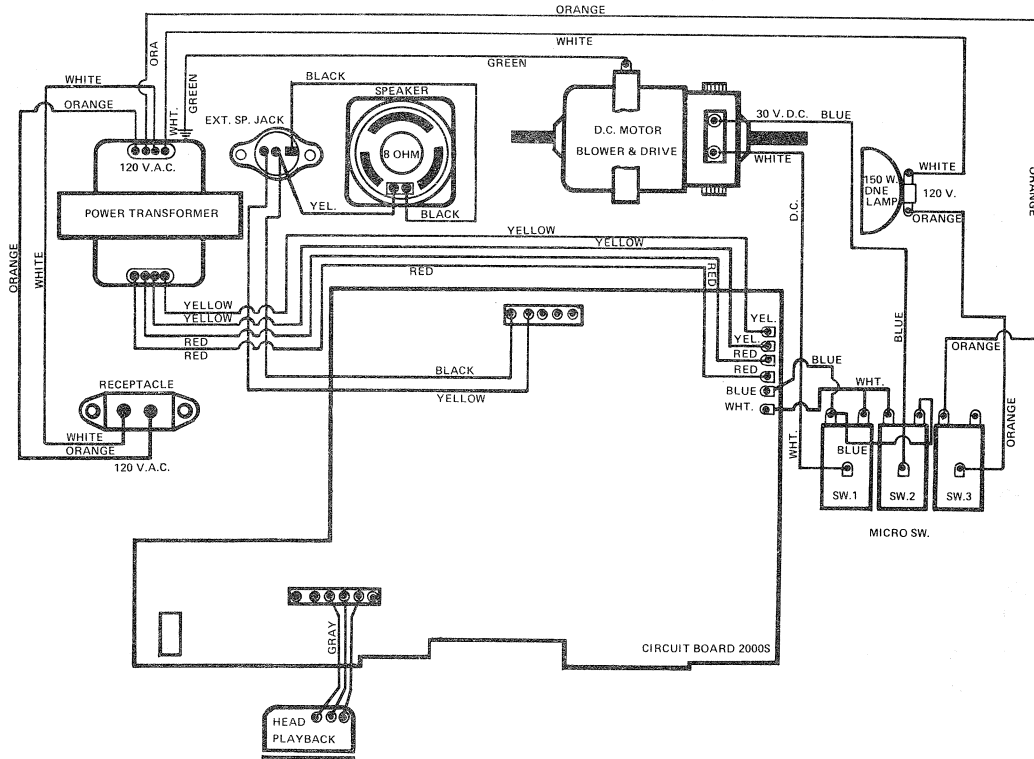

3000S

